

Part Number: L-36BID

High Efficiency Red

Features

- T-1 package with rectangular base.
- With built-in blinking IC.
- Operation voltage from 3.5V to 14V.
- Blinking frequency from 3.0Hz to 1.5Hz.
- RoHS compliant.

Description

The High Efficiency Red source color devices are made with Gallium Arsenide Phosphide on Gallium Phosphide Orange Light Emitting Diode.

Package Dimensions

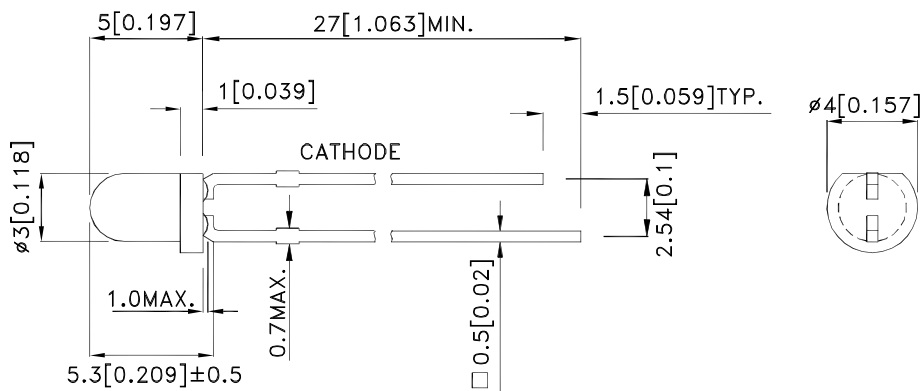

Notes:

1. All dimensions are in millimeters (inches).
2. Tolerance is $\pm 0.25(0.01)$ unless otherwise noted.
3. Lead spacing is measured where the leads emerge from the package.
4. The specifications, characteristics and technical data described in the datasheet are subject to change without prior notice.



Selection Guide

| Part No. | Dice | Lens Type | Iv (mcd) V= 9V | | Viewing Angle [1] |
|----------|---------------------------------|--------------|-------------------|------|-------------------|
| | | | Min. | Typ. | 2θ1/2 |
| L-36BID | High Efficiency Red (GaAsP/GaP) | Red Diffused | 15 | 30 | 60° |

Note:

1. θ1/2 is the angle from optical centerline where the luminous intensity is 1/2 of the optical peak value.

Electrical / Optical Characteristics at TA=25°C

| Symbol | Parameter | Device | Min. | Typ. | Max. | Units | Test Conditions |
|-------------------|--------------------------|---------------------|------|------|------|-------|--|
| λ _{peak} | Peak Wavelength | High Efficiency Red | | 627 | | nm | |
| λ _D | Dominant Wavelength | High Efficiency Red | | 625 | | nm | |
| Δλ _{1/2} | Spectral Line Half-width | High Efficiency Red | | 45 | | nm | |
| I _F | Forward Current | High Efficiency Red | 8 | 22 | | mA | Min:V _F =3.5V Typ:V _F =5V |
| I _{SON} | Supply Current | High Efficiency Red | | 8 | | mA | V _F =3.5V |
| I _{SON} | Supply Current | High Efficiency Red | | 44 | | mA | V _F =14V |
| f | Blink Frequency | High Efficiency Red | 1.5 | | 3 | Hz | V _F =3.5V~14V |

Absolute Maximum Ratings at TA=25°C

| Parameter | High Efficiency Red | Units |
|-----------------------------|---------------------|-------|
| Power dissipation | 310 | mW |
| Forward Voltage | 14 | V |
| Reverse Voltage | 0.5 | V |
| Operating Temperature | -40°C To +70°C | |
| Storage Temperature | -40°C To +85°C | |
| Lead Solder Temperature [1] | 260°C For 3 Seconds | |
| Lead Solder Temperature [2] | 260°C For 5 Seconds | |

Notes:

1. 2mm below package base.
2. 5mm below package base.

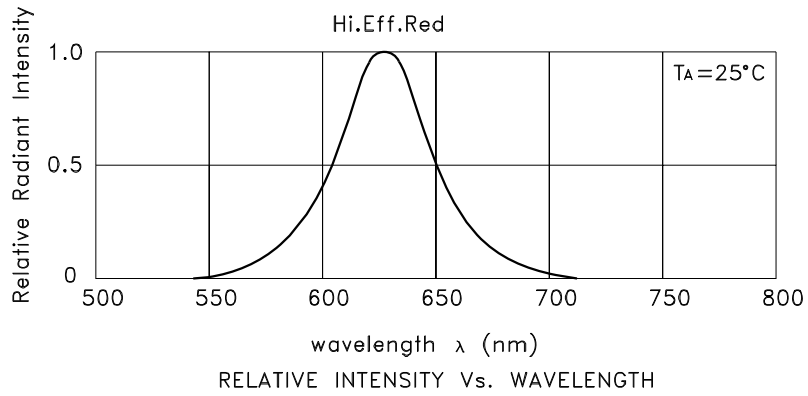

High Efficiency Red L-36BID

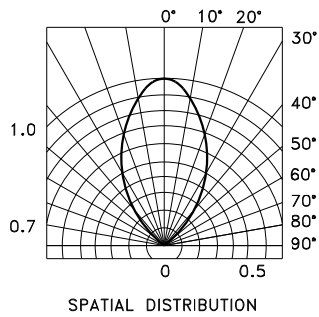
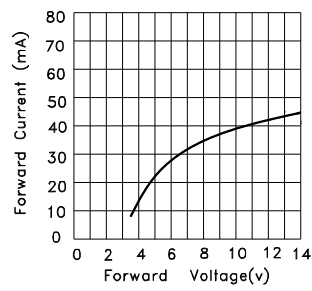
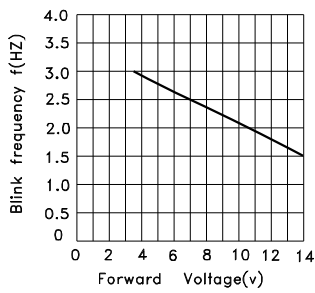

PACKING & LABEL SPECIFICATIONS

L-36BID

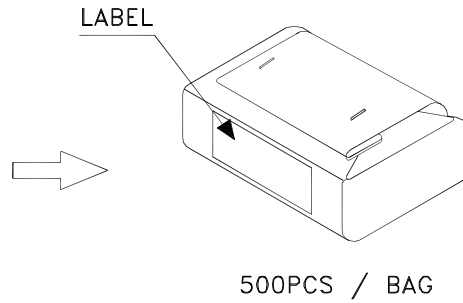
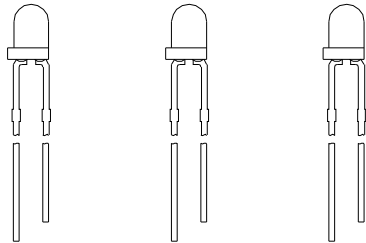

32K / 9# BOX

OUTSIDE LABEL

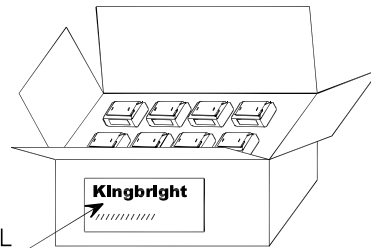
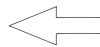

OUTSIDE LABEL

16K / 5# BOX

| | | | | | |
|------------------------------|------|---|-----|------------|--------|
| Kingbright | | | | | |
| P/NO: L-36Bxxx | | | | | |
| QTY: 500 pcs | Q.C. | <table border="1"> <tr> <td>Q C</td> </tr> <tr> <td>xx xx xxxx</td> </tr> <tr> <td>PASSED</td> </tr> </table> | Q C | xx xx xxxx | PASSED |
| Q C | | | | | |
| xx xx xxxx | | | | | |
| PASSED | | | | | |
| S/N: XXXX | | | | | |
| CODE: XXX | | | | | |
| LOT NO: | | | | | |
| xxxxxxxxxxxxxxxxxxxxxxxx | | | | | |
| RoHS Compliant | | | | | |

PRECAUTIONS

1. The lead pitch of the LED must match the pitch of the mounting holes on the PCB during component placement. Lead-forming may be required to insure the lead pitch matches the hole pitch. Refer to the figure below for proper lead forming procedures. (Fig. 1)

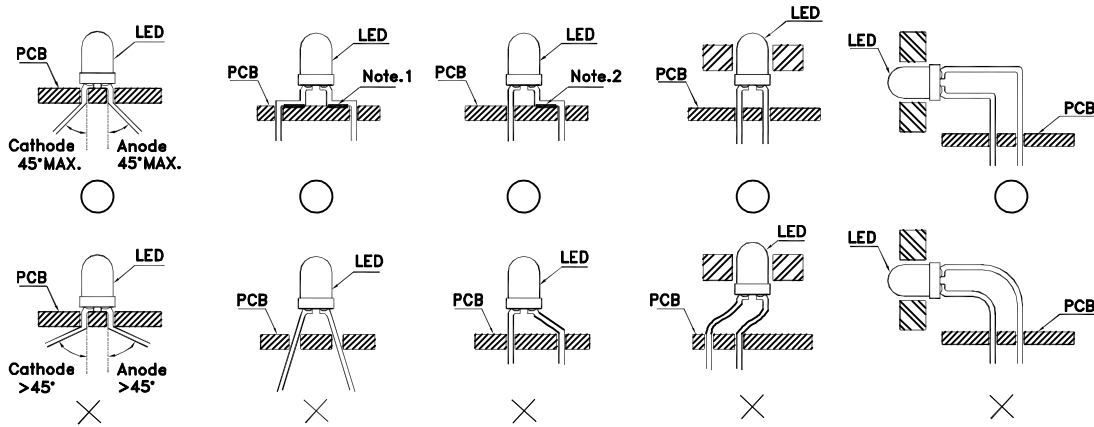

Fig.1

”○” Correct mounting method ”×” Incorrect mounting method

2. When soldering wire to the LED, use individual heat-shrink tubing to insulate the exposed leads to prevent accidental contact short-circuit. (Fig.2)

3. Use stand-offs (Fig.3) or spacers (Fig.4) to securely position the LED above the PCB.

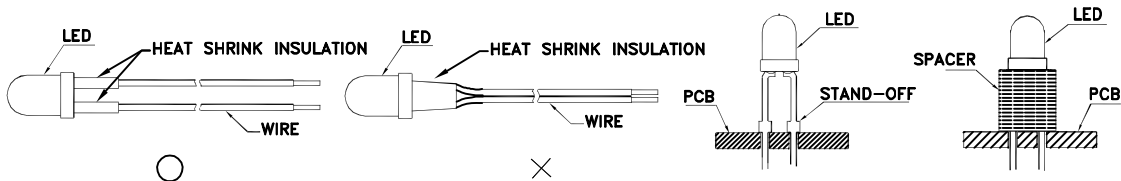

Fig. 2

Fig. 3

Fig. 4

4. Maintain a minimum of 2mm clearance between the base of the LED lens and the first lead bend. (Fig. 5 and 6)
5. During lead forming, use tools or jigs to hold the leads securely so that the bending force will not be transmitted to the LED lens and its internal structures. Do not perform lead forming once the component has been mounted onto the PCB. (Fig. 7)

6. Do not bend the leads more than twice. (Fig. 8)

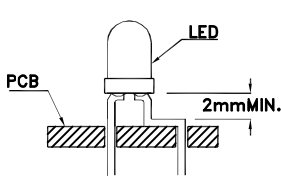

Fig. 5

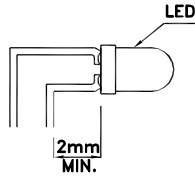

Fig. 6

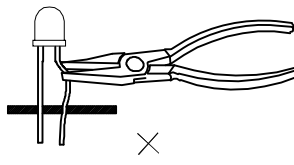

Fig. 7

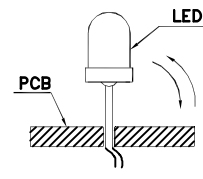
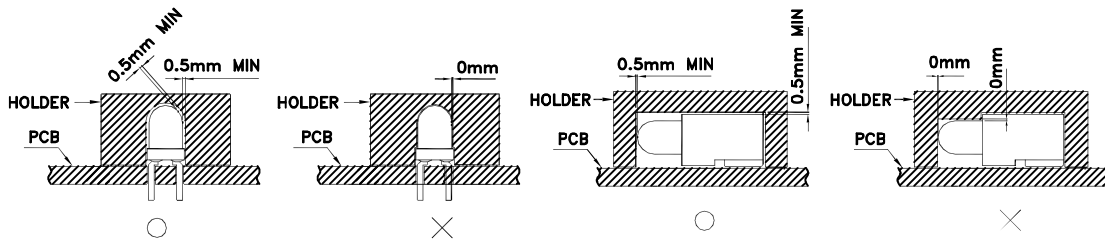

Fig. 8

7. During soldering, component covers and holders should leave clearance to avoid placing damaging stress on the LED during soldering.



8. The tip of the soldering iron should never touch the lens epoxy.

9. Through-hole LEDs are incompatible with reflow soldering.

10. If the LED will undergo multiple soldering passes or face other processes where the part may be subjected to intense heat, please check with Kingbright for compatibility.

11. Recommended Wave Soldering Profile for Kingbright Thru-Hole Products

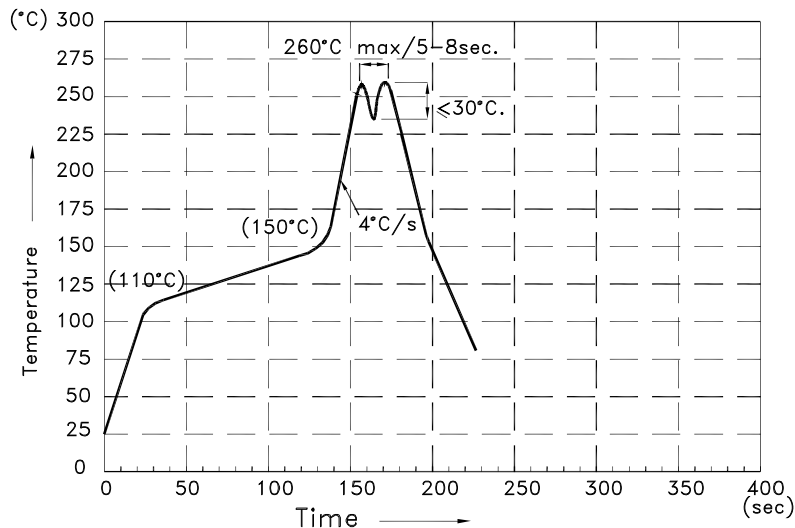

NOTES:

1. Recommend the wave temperature 245°C~260°C. The maximum soldering temperature should be less than 260°C.
2. Do not apply stress on epoxy resins when temperature is over 85°C.
3. The soldering profile apply to the lead free soldering (Sn/Cu/Ag alloy).
4. During wave soldering, the PCB top-surface temperature should be kept below 105°C.
5. No more than once.