

Part Number: KAAF5051QB25SE24ZG25Z1X3S



ATTENTION
OBSERVE PRECAUTIONS
FOR HANDLING
ELECTROSTATIC
DISCHARGE
SENSITIVE
DEVICES

Blue
Reddish-Orange
Green

Features

- Chips can be controlled separately.
- Suitable for all SMT assembly and solder process.
- Available on tape and reel.
- White SMD package, silicone resin.
- Package: 500pcs / reel.
- Moisture sensitivity level : level 3.
- RoHS compliant.

Description

The Blue source color devices are made with InGaN on Al₂O₃ substrate Light Emitting Diode.

The Reddish-Orange source color devices are made with AlGaInP on AlN substrate Light Emitting Diode.

The Green source color devices are made with InGaN on Al₂O₃ substrate Light Emitting Diode.

Static electricity and surge damage the LEDs.

It is recommended to use a wrist band or anti-electrostatic glove when handling the LEDs.

All devices, equipment and machinery must be electrically grounded.

Package Dimensions

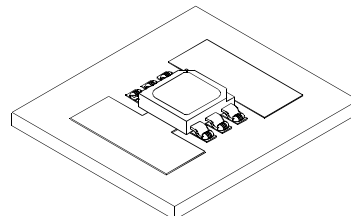
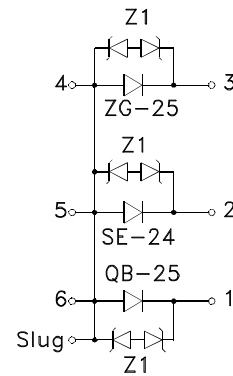
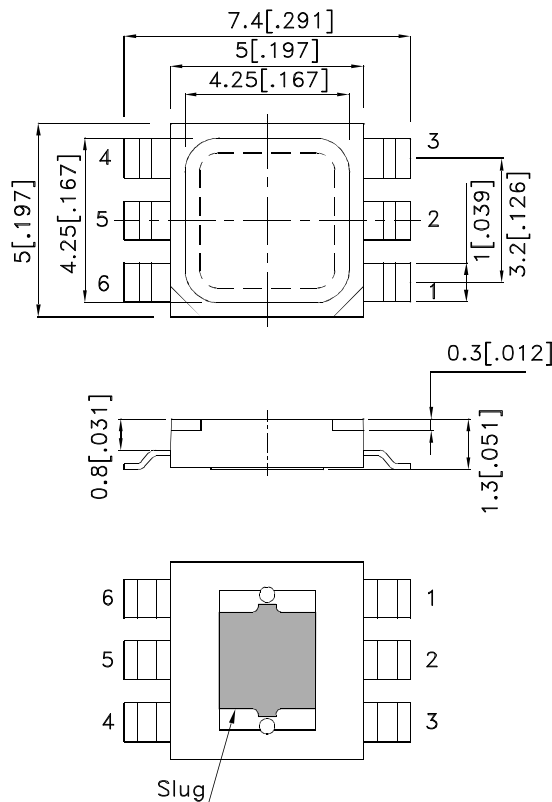

Notes:

1. All dimensions are in millimeters (inches).
2. Tolerance is $\pm 0.15[\pm 0.006]$ unless otherwise noted.
3. The specifications, characteristics and technical data described in the datasheet are subject to change without prior notice.
4. The device has a single mounting surface. The device must be mounted according to the specifications.



Handling Precautions

Compare to epoxy encapsulant that is hard and brittle, silicone is softer and flexible. Although its characteristic significantly reduces thermal stress, it is more susceptible to damage by external mechanical force.

As a result, special handling precautions need to be observed during assembly using silicone encapsulated LED products. Failure to comply might lead to damage and premature failure of the LED.

1. Handle the component along the side surfaces by using forceps or appropriate tools.

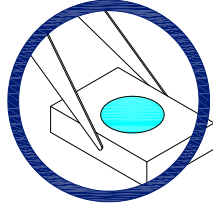

2. Do not directly touch or handle the silicone lens surface. It may damage the internal circuitry.

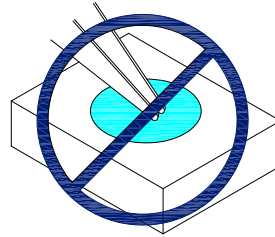
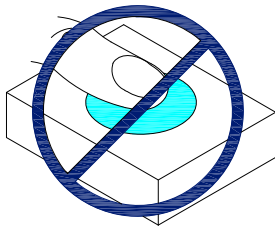

3. Do not stack together assembled PCBs containing exposed LEDs. Impact may scratch the silicone lens or damage the internal circuitry.

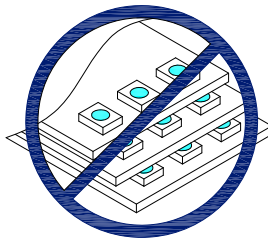

4.1. The outer diameter of the SMD pickup nozzle should not exceed the size of the LED to prevent air leaks. The inner diameter of the nozzle should be as large as possible.

4.2. A pliable material is suggested for the nozzle tip to avoid scratching or damaging the LED surface during pickup.

4.3. The dimensions of the component must be accurately programmed in the pick-and-place machine to insure precise pickup and avoid damage during production.

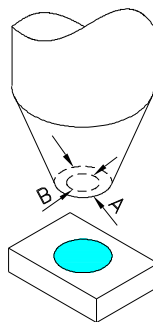

5. As silicone encapsulation is permeable to gases, some corrosive substances such as H₂S might corrode silver plating of leadframe. Special care should be taken if an LED with silicone encapsulation is to be used near such substances.

Selection Guide

Part No.	Dice	Lens Type	Iv (mcd) [2] @ 150mA		Φv (mlm) [2] @ 150mA		Viewing Angle [1]
			Min.	Typ.	Min.	Typ.	2θ1/2
KAAF5051QB25SE24ZG25Z1X3S	Blue (InGaN)	Water Clear	700	1300	3500	5000	120°
	Reddish-Orange (AlGaInP)		8000	13000	8600	11000	
	Green (InGaN)		4700	6500	14000	20000	

Notes:

- θ1/2 is the angle from optical centerline where the luminous intensity is 1/2 of the optical peak value.
- Luminous intensity/ luminous Flux: +/-15%.

Absolute Maximum Ratings at Ta=25°C

Parameter	Symbol	Device	Value	Unit	Test Conditions
Power dissipation	Pd	Blue	0.6	W	If=150mA If=150mA If=150mA
		Reddish-Orange	0.45		
		Green	0.6		
Junction temperature	Tj	Blue	110	°C	If=150mA If=150mA If=150mA
		Reddish-Orange	110		
		Green	110		
Operating Temperature	Top	Blue	-40 To +85	°C	If=150mA If=150mA If=150mA
		Reddish-Orange			
		Green			
Storage Temperature	Tstg	Blue	-40 To +85	°C	If=150mA If=150mA If=150mA
		Reddish-Orange			
		Green			
DC Forward Current [1]	If	Blue	150	mA	If=150mA If=150mA If=150mA
		Reddish-Orange	150		
		Green	150		
Peak Forward Current [2]	IfM	Blue	300	mA	If=150mA If=150mA If=150mA
		Reddish-Orange	300		
		Green	300		
Thermal resistance	Rth j-a	Blue	220	°C/W	If=150mA If=150mA If=150mA
		Reddish-Orange	270		
		Green	200		
Thermal resistance	Rth j-s	Blue	25	°C/W	If=150mA If=150mA If=150mA
		Reddish-Orange	40		
		Green	33		
Allowable Reverse Current	IR	Blue	85	mA	VR=5V
		Reddish-Orange	85		
		Green	85		

Notes:

- Results from mounting on Aluminum Board.
- 1/10 Duty Cycle, 0.1ms Pulse Width.

Electrical / Optical Characteristics at T_a=25°C

Parameter	Symbol	Device	Value			Unit
			Min.	Typ.	Max.	
Wavelength at peak emission I _F =150mA	λ peak	Blue		445		nm
Wavelength at peak emission I _F =150mA		Reddish-Orange		635		
Wavelength at peak emission I _F =150mA		Green		515		
Dominant Wavelength I _F =150mA	λ dom [1]	Blue		450		nm
Dominant Wavelength I _F =150mA		Reddish-Orange		624		
Dominant Wavelength I _F =150mA		Green		525		
Spectral Line Half-width I _F =150mA	Δλ1/2	Blue		20		nm
Spectral Line Half-width I _F =150mA		Reddish-Orange		20		
Spectral Line Half-width I _F =150mA		Green		30		
Forward Voltage I _F =150mA	V _F [2]	Blue	3.0	3.5	4.0	V
Forward Voltage I _F =150mA		Reddish-Orange	2.0	2.5	3.0	
Forward Voltage I _F =150mA		Green	3.0	3.5	4.0	
Reverse Voltage	V _R	Blue		5		V
		Reddish-Orange		5		
		Green		5		
Temperature coefficient of λ peak I _F =150mA, -10 ° C ≤ T ≤ 100 ° C	TC λ peak	Blue		0.12		nm/° C
Temperature coefficient of λ peak I _F =150mA, -10 ° C ≤ T ≤ 100 ° C		Reddish-Orange		0.09		
Temperature coefficient of λ peak I _F =150mA, -10 ° C ≤ T ≤ 100 ° C		Green		0.13		
Temperature coefficient of λ dom I _F =150mA, -10 ° C ≤ T ≤ 100 ° C	TC λ dom	Blue		0.1		nm/° C
Temperature coefficient of λ dom I _F =150mA, -10 ° C ≤ T ≤ 100 ° C		Reddish-Orange		0.03		
Temperature coefficient of λ dom I _F =150mA, -10 ° C ≤ T ≤ 100 ° C		Green		0.11		
Temperature coefficient of V _F I _F =150mA, -10 ° C ≤ T ≤ 100 ° C	TC _V	Blue		-2.3		mV/° C
Temperature coefficient of V _F I _F =150mA, -10 ° C ≤ T ≤ 100 ° C		Reddish-Orange		-2.7		
Temperature coefficient of V _F I _F =150mA, -10 ° C ≤ T ≤ 100 ° C		Green		-3.9		

Notes:

- 1.Wavelength: +/-1nm.
2. Forward Voltage: +/-0.2V.

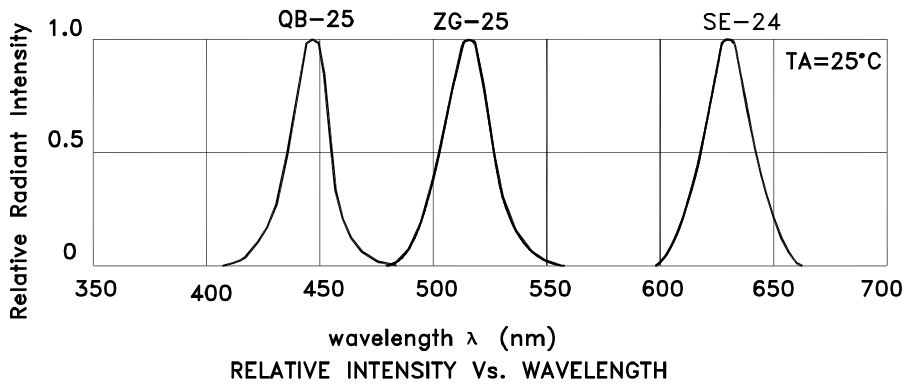

KAAF5051QB25SE24ZG25Z1X3S
Blue

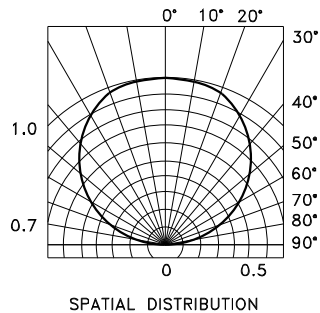
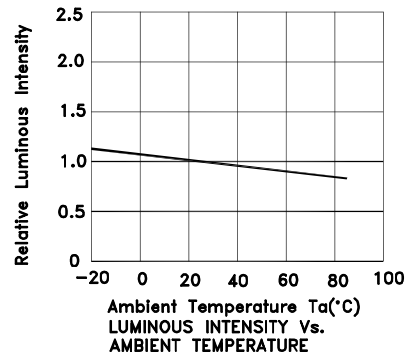
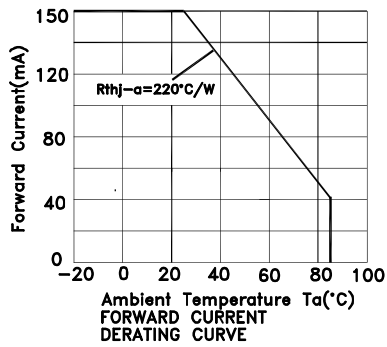
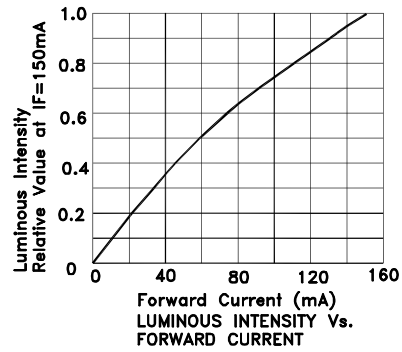
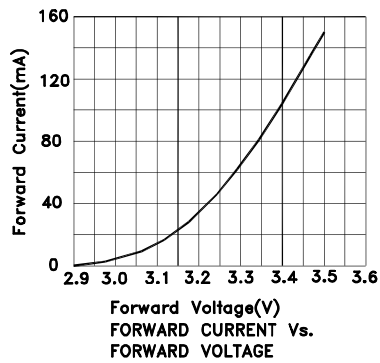

Reddish-orange

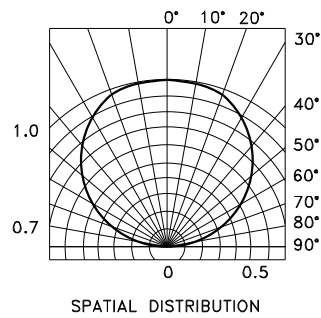
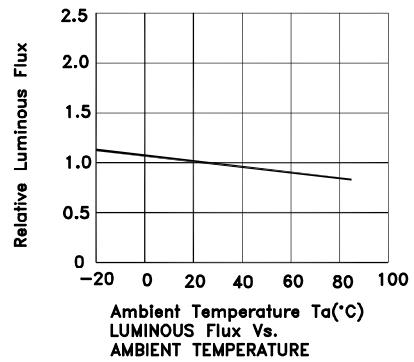
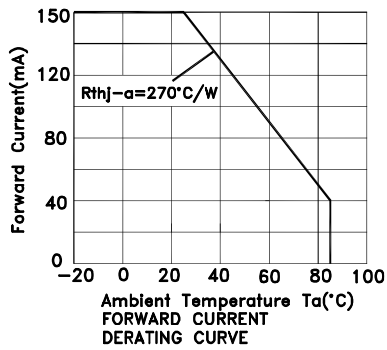
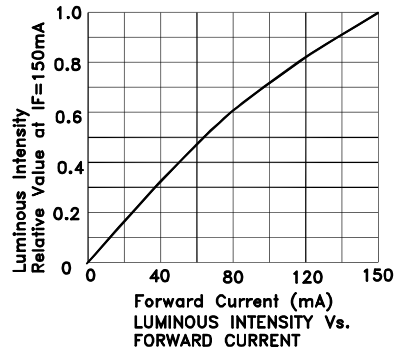
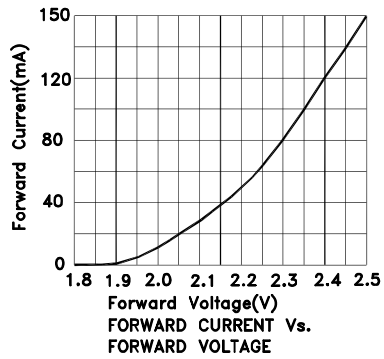

Kingbright

Green

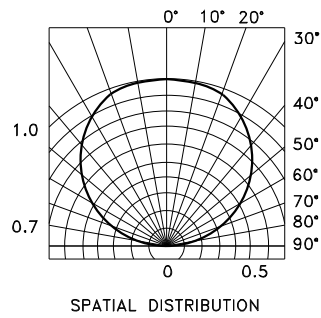
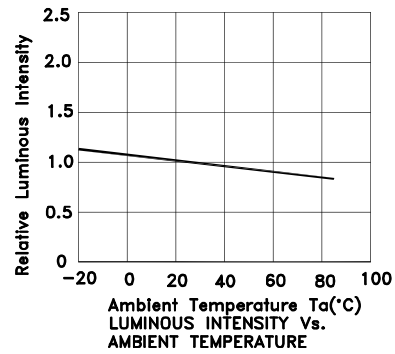
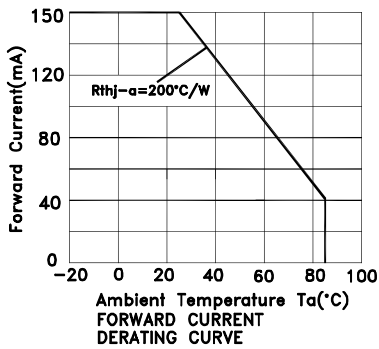
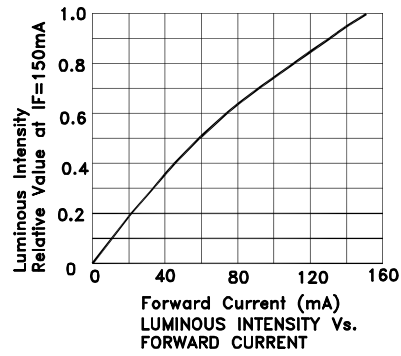
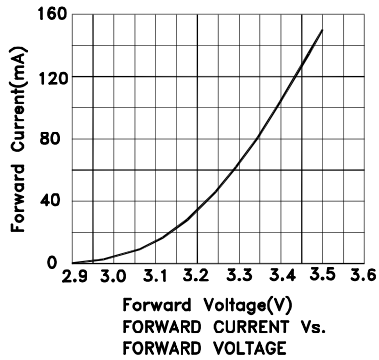

KAAF5051QB25SE24ZG25Z1X3S

Reflow soldering is recommended and the soldering profile is shown below.
Other soldering methods are not recommended as they might cause damage to the product.

Reflow Soldering Profile For Lead-free SMT Process.

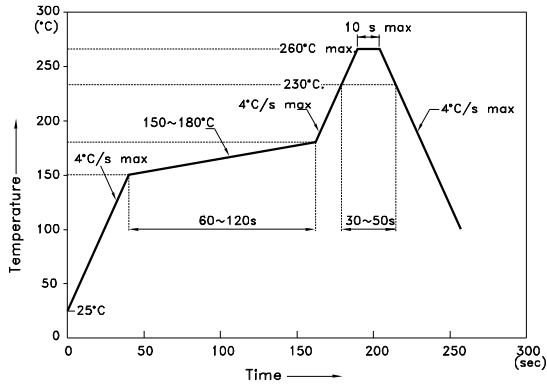

- NOTES:
1. We recommend the reflow temperature 245°C(+/-5°C). The maximum soldering temperature should be limited to 260°C.
 2. Don't cause stress to the epoxy resin while it is exposed to high temperature.
 3. Number of reflow process shall be 2 times or less.

Reel Dimension

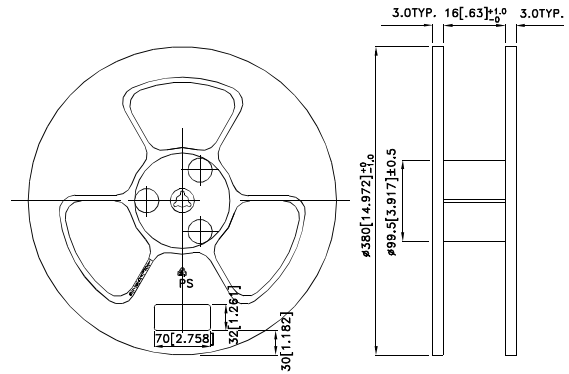

Recommended Soldering Pattern (Units : mm; Tolerance: ± 0.1)

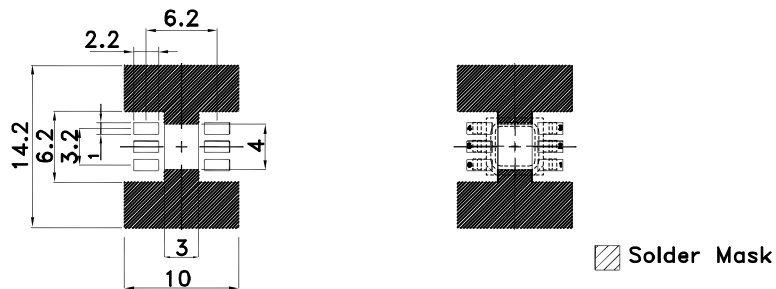

Tape Specifications (Units : mm)

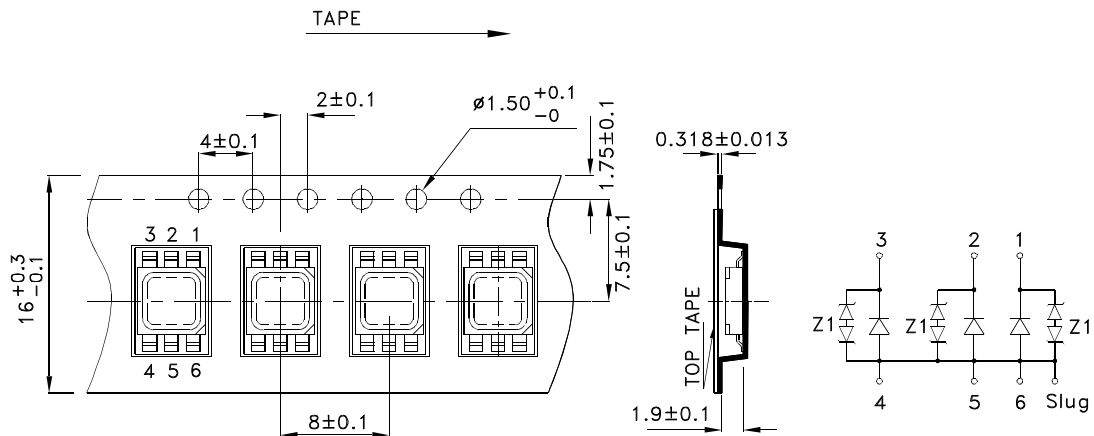

Kingbright

PACKING & LABEL SPECIFICATIONS

KAAF5051QB25SE24ZG25Z1X3S

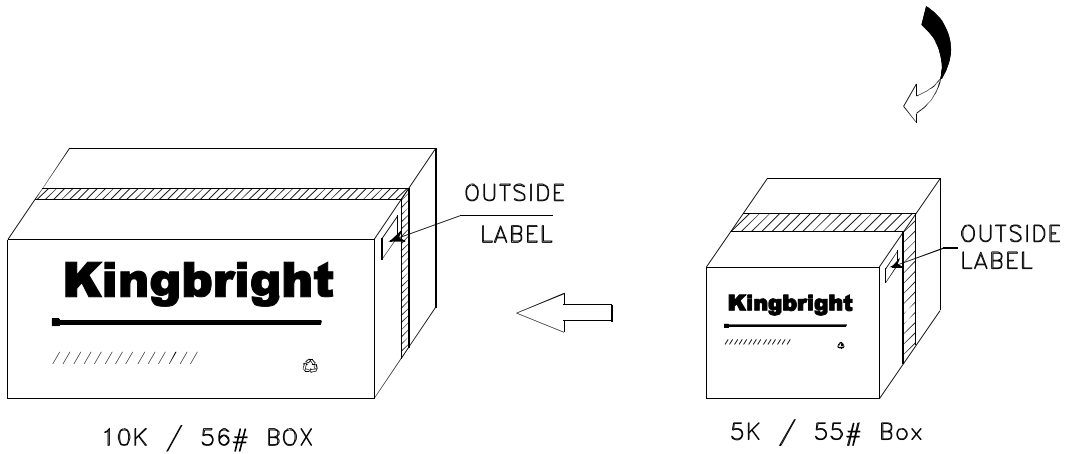
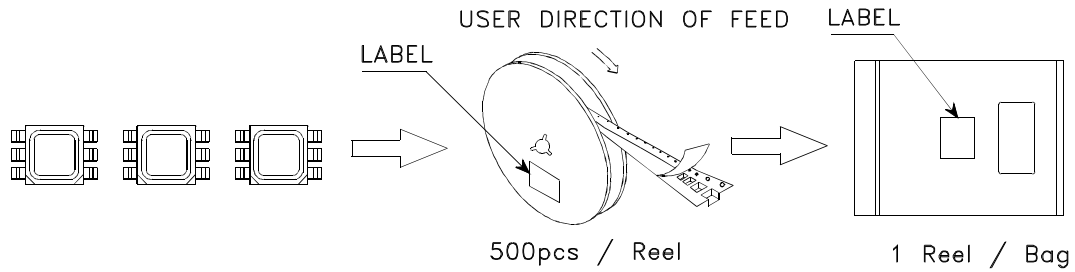

Kingbright	
P/NO: KAAF5051xxx	
QTY: 500 pcs	Q.C. Q C xx xx xxxx PASSED
S/N: XXXX	
CODE: XXX	
LOT NO:	
 <small>XXXXXXXXXXXXXXXXXXXX</small>	
RoHS Compliant	