

### PRELIMINARY SPEC

Part Number: KAAF-5052XSY28Z4XS



**ATTENTION**  
OBSERVE PRECAUTIONS  
FOR HANDLING  
ELECTROSTATIC  
DISCHARGE  
SENSITIVE  
DEVICES

Super Bright Yellow

### Features

- Suitable for all SMT assembly and solder process.
- Available on tape and reel.
- White SMD package, silicone resin.
- Package: 500pcs / reel.
- Moisture sensitivity level : level 3.
- RoHS compliant.

### Description

Static electricity and surge damage the LEDs.

It is recommended to use a wrist band or anti-electrostatic glove when handling the LEDs.

All devices, equipment and machinery must be electrically grounded.

### Package Dimensions

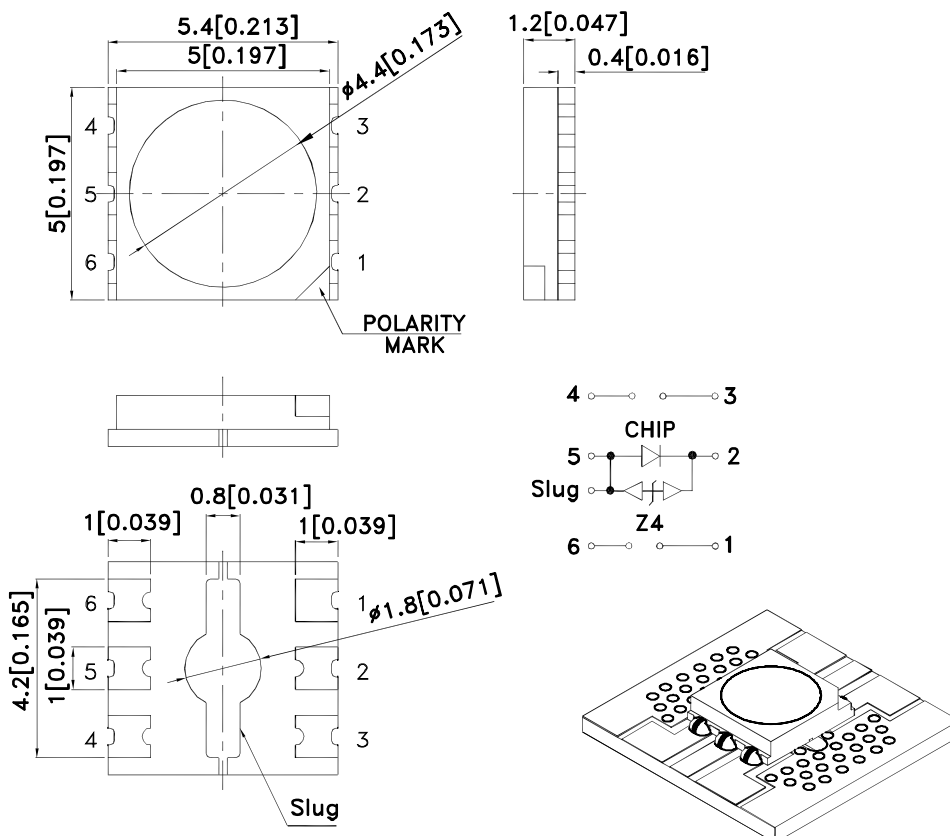

#### Notes:

1. All dimensions are in millimeters (inches).
2. Tolerance is  $\pm 0.25$  [±0.01] unless otherwise noted.
3. The specifications, characteristics and technical data described in the datasheet are subject to change without prior notice.
4. The device has a single mounting surface. The device must be mounted according to the specifications.



## Handling Precautions

Compare to epoxy encapsulant that is hard and brittle, silicone is softer and flexible. Although its characteristic significantly reduces thermal stress, it is more susceptible to damage by external mechanical force.

As a result, special handling precautions need to be observed during assembly using silicone encapsulated LED products. Failure to comply might lead to damage and premature failure of the LED.

1. Handle the component along the side surfaces by using forceps or appropriate tools.

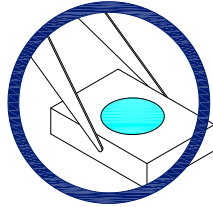

2. Do not directly touch or handle the silicone lens surface. It may damage the internal circuitry.

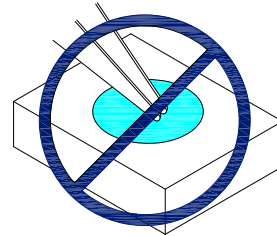
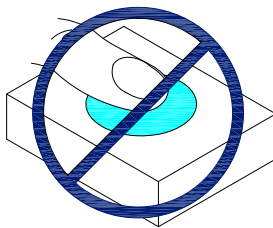

3. Do not stack together assembled PCBs containing exposed LEDs. Impact may scratch the silicone lens or damage the internal circuitry.

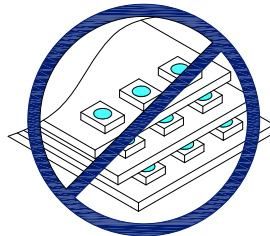

- 4.1. The inner diameter of the SMD pickup nozzle should not exceed the size of the LED to prevent air leaks.
- 4.2. A pliable material is suggested for the nozzle tip to avoid scratching or damaging the LED surface during pickup.
- 4.3. The dimensions of the component must be accurately programmed in the pick-and-place machine to insure precise pickup and avoid damage during production.

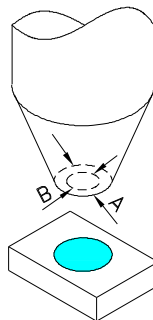

5. As silicone encapsulation is permeable to gases, some corrosive substances such as  $H_2S$  might corrode silver plating of leadframe. Special care should be taken if an LED with silicone encapsulation is to be used near such substances.

## Selection Guide

Part No.	Dice	Lens Type	Iv (cd) [2] @ 350mA		Φv (lm) [2] @ 350mA*		Viewing Angle [1]
			Min.	Typ.	Min.	Typ.	2θ1/2
KAAF-5052XSY28Z4XS	Super Bright Yellow (AlGaInP)	Water Clear	6.7	8.1	12	17	120°

Notes:

1. θ1/2 is the angle from optical centerline where the luminous intensity is 1/2 of the optical peak value.
2. Luminous intensity / luminous flux: +/-15%.\*LEDs are binned according to their luminous flux.
3. Luminous intensity/ luminous Flux value is traceable to the CIE127-2007 compliant national standards.

## Absolute Maximum Ratings at Ta=25°C

Parameter	Symbol	Value	Unit
Power dissipation	P <sub>D</sub>	1.05	W
Junction temperature	T <sub>J</sub>	110	°C
Reverse Voltage	V <sub>R</sub>	5	V
Operating Temperature	T <sub>op</sub>	-40 To +100	°C
Storage Temperature	T <sub>stg</sub>	-40 To +110	°C
DC Forward Current [1]	I <sub>F</sub>	350	mA
Peak Forward Current [2]	I <sub>FM</sub>	500	mA
Thermal resistance	R <sub>th j-a</sub>	12	°C/W
Electrostatic Discharge Threshold (HBM)		8000	V

Notes:

1. Results from mounting on metal core PCB, mounted on pc board-metal core PCB is recommend. for lowest thermal resistance.
2. 1/10 Duty Cycle, 0.1ms Pulse Width.

## Electrical / Optical Characteristics at Ta=25°C

Parameter	Symbol	Value			Unit
		Min.	Typ.	Max.	
Wavelength at peak emission I <sub>F</sub> =350mA	λ <sub>peak</sub>		594		nm
Dominant Wavelength I <sub>F</sub> =350mA	λ <sub>dom</sub> [1]		593		nm
Spectral Line Half-width I <sub>F</sub> =350mA	Δλ <sub>1/2</sub>		20		nm
Allowable Reverse Current	I <sub>R</sub>			85	mA
Forward Voltage I <sub>F</sub> =350mA	V <sub>F</sub> [2]	2.0	2.5	3.0	V
Temperature coefficient of λ <sub>peak</sub> I <sub>F</sub> =350mA, -10 ° C ≤ T ≤ 100 ° C	TC λ <sub>peak</sub>		0.09		nm/° C
Temperature coefficient of λ <sub>dom</sub> I <sub>F</sub> =350mA, -10 ° C ≤ T ≤ 100 ° C	TC λ <sub>dom</sub>		0.06		nm/° C
Temperature coefficient of V <sub>F</sub> I <sub>F</sub> =350mA, -10 ° C ≤ T ≤ 100 ° C	TC <sub>V</sub>		-3.2		mV/° C

Notes:

- 1.Wavelength: +/-1nm.
2. Forward Voltage: +/-0.1V.
3. Wavelength value is traceable to the CIE127-2007 compliant national standards.

## KAAF-5052XSY28Z4XS

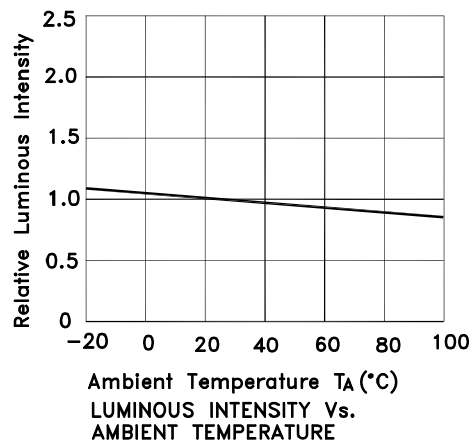
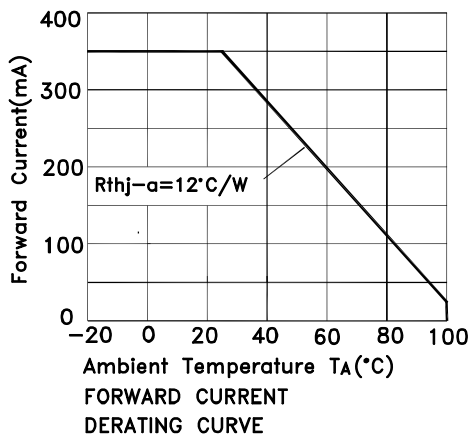
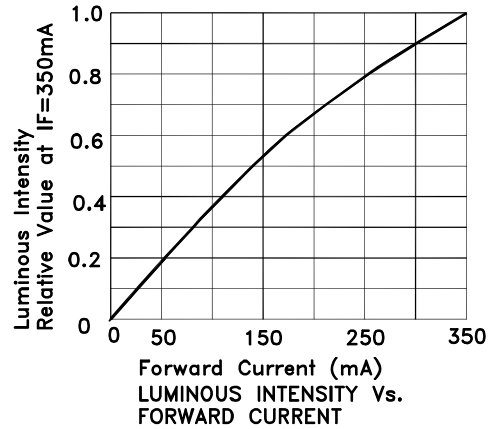
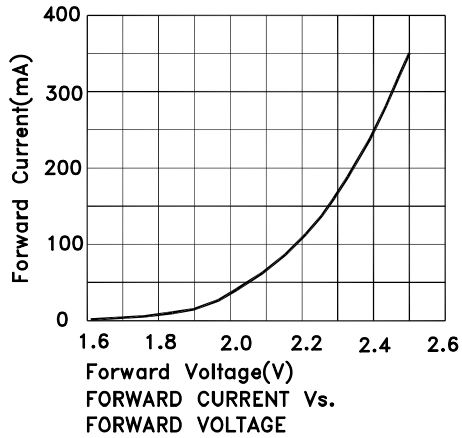
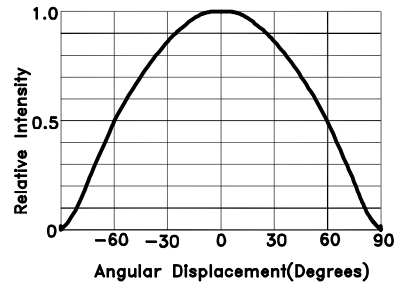
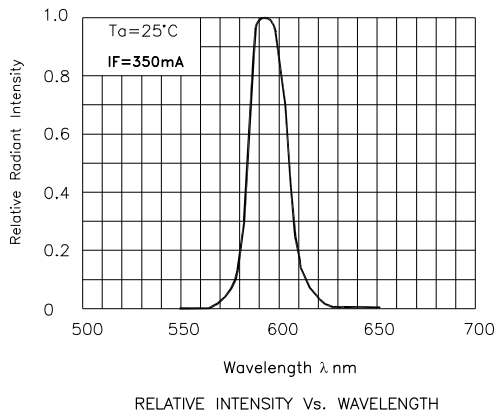

## KAAF-5052XSY28Z4XS

Reflow soldering is recommended and the soldering profile is shown below.  
Other soldering methods are not recommended as they might cause damage to the product.

Reflow Soldering Profile For Lead-free SMT Process.

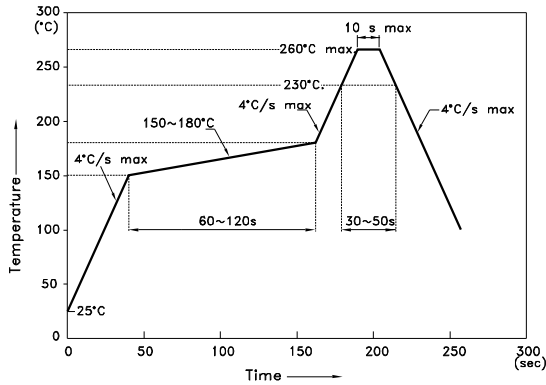

NOTES:

1. We recommend the reflow temperature 245°C(+/-5°C). The maximum soldering temperature should be limited to 260°C.
2. Don't cause stress to the epoxy resin while it is exposed to high temperature.
3. Number of reflow process shall be 2 times or less.

### Reel Dimension

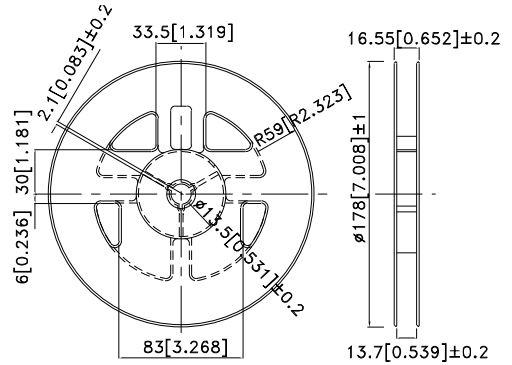

### Recommended Soldering Pattern (Units : mm; Tolerance: ± 0.1)

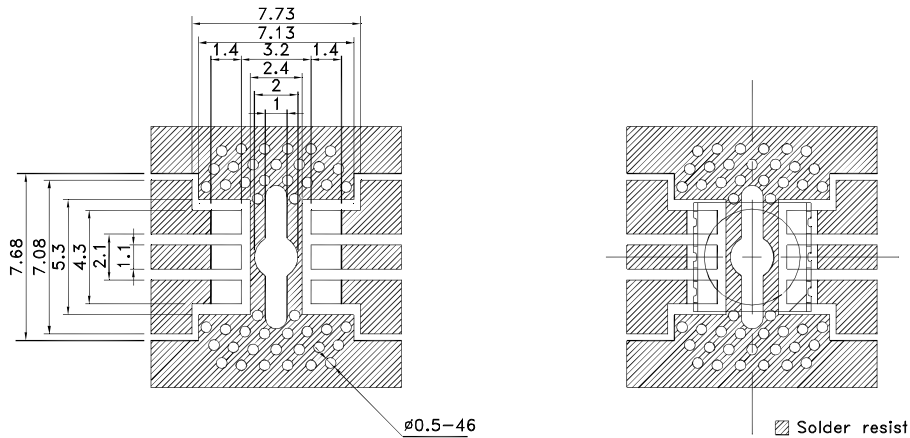

### Tape Dimensions (Units : mm)

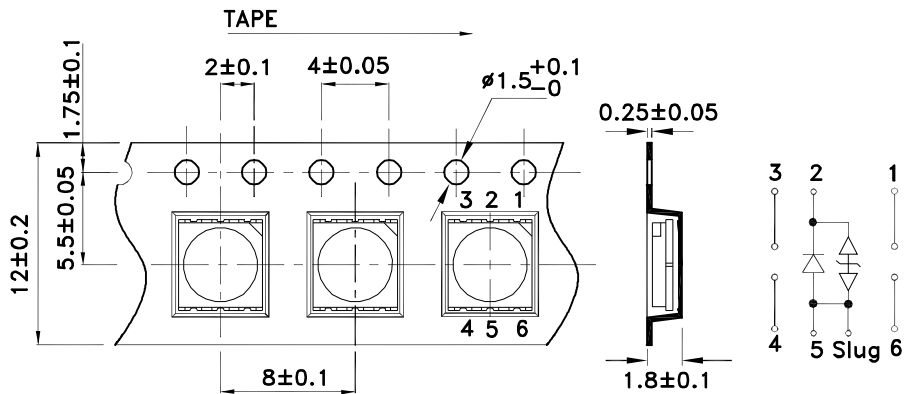

# Kingbright

## PACKING & LABEL SPECIFICATIONS

## KAAF-5052XS28Z4XS

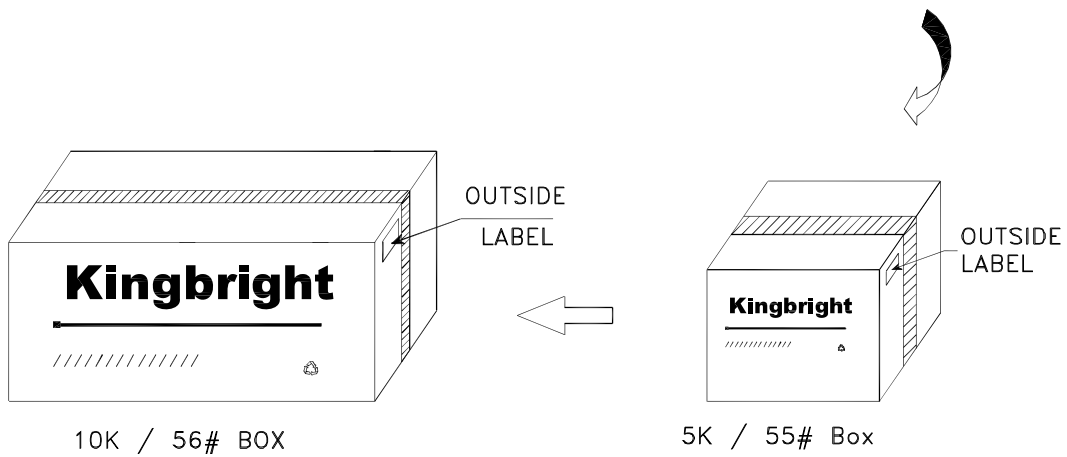
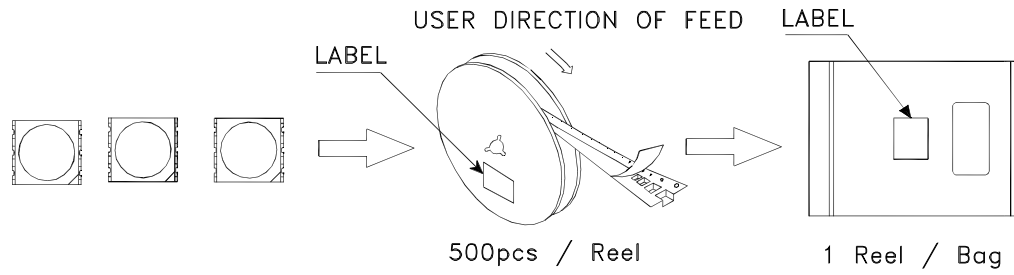

<h1>Kingbright</h1>	
P/NO: KAAF-5052xxx	
QTY: 500 pcs	Q.C. <span style="border: 1px solid black; border-radius: 50%; padding: 2px;">Q C xx xx xxxx PASSED</span>
S/N: XXXX	
CODE: CIE:XXX	
LOT NO:	
 XXXXXXXXXXXXXXXXXXXXXXXX	
RoHS Compliant	