

UT80CRH196KD Microcontroller



September, 2002

FEATURES

- ❑ 20MHz 16-bit Microcontroller compatible with industry standard's MCS-96 ISA
 - Register to Register Architecture
 - 1000 Byte Register RAM
- ❑ Three 8-bit I/O Ports
- ❑ On-board Interrupt Controller
- ❑ Three Pulse-Width Modulated Outputs
- ❑ High Speed I/O
- ❑ UART Serial Port
- ❑ Dedicated Baud Rate Generator
- ❑ Software and Hardware Timers
 - 16-Bit Watchdog Timer, Four 16-Bit Software Timers
 - Three 16-Bit Counter/Timers
- ❑ Radiation-hardened process and design; total dose irradiation testing to MIL-STD-883 Method 1019
 - Total-dose: 100K rads(Si)
 - Effective LET threshold: 25 MeV-cm²/mg
 - Saturated cross section: 3.66e-7cm²/bit
 - Latchup immune (LET > 128 MeV-cm²/mg)
- ❑ Error detection and correction for external memory accesses
- ❑ QML Q and QML V compliant part
- ❑ Standard Microcircuit Drawing 5962-98583

INTRODUCTION

The UT80CRH196KD is compatible with industry standard's MCS-96 instruction set. The UT80CRH196KD is supported by commercial hardware and software development tools.

Built on UTMC's Commercial RadHard™ epitaxial CMOS technology, the microcontroller is hardened against ionizing dose and charged particles. The microcontroller's on-board 1000 byte scratch-pad SRAM and flip-flops can withstand charged particles with energies up to 25 MeV-cm²/mg. The UT80CRH196KD accesses instruction code and data via a 16-bit address and data bus. The 16-bit bus allows the microcontroller to access 128K bytes of instruction/data memory. Integrated software and hardware timers, high speed I/O, pulse width modulation circuitry, and UART make the UT80CRH196KD ideal for control type applications. The CPU's ALU supports byte and word adds and subtracts, 8 and 16 bit multiplies, 32/16 and 16/8 bit divides, as well as increment, decrement, negate, compare, and logical operations. The UT80CRH196KD's interrupt controller prioritizes and vectors 18 interrupt events. Interrupts include normal interrupts and special interrupts. To reduce power consumption, the microcontroller supports software invoked idle and power down modes. The UT80CRH196KD is packaged in a 68-lead quad flatpack.

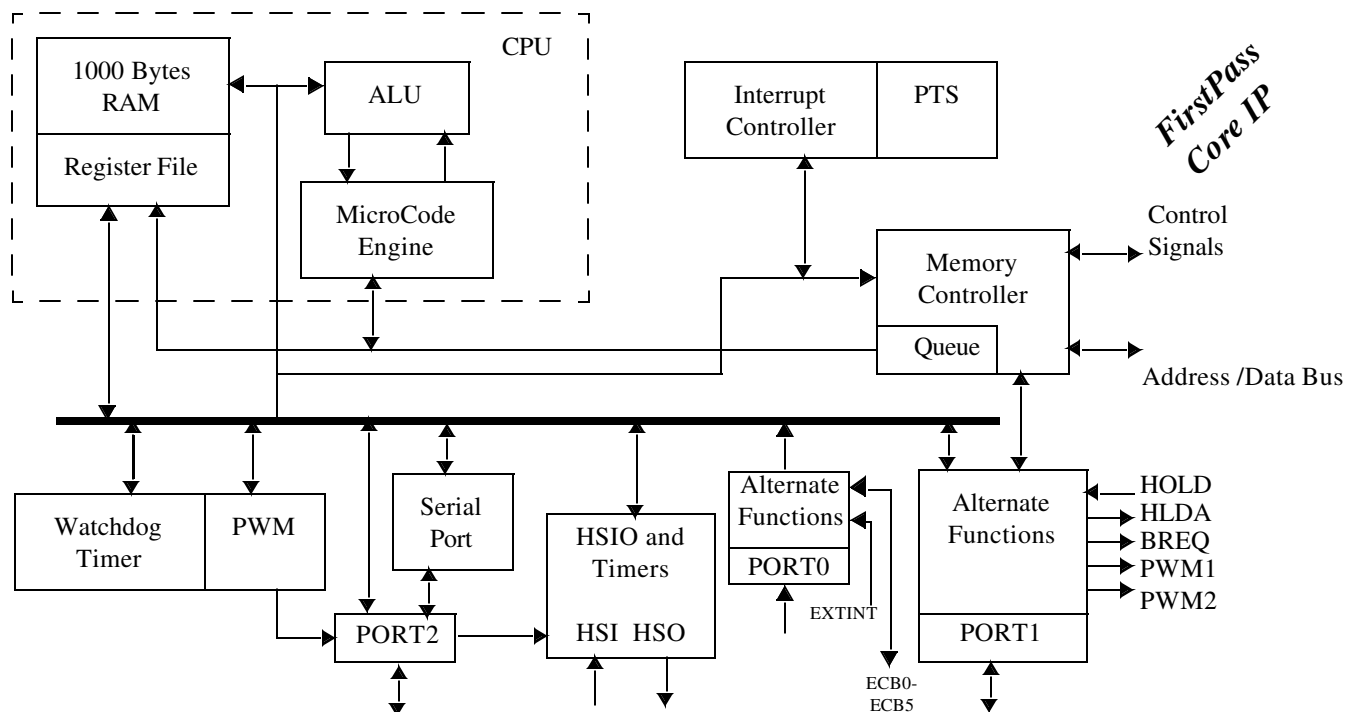

Figure 1. UT80CRH196KD Microcontroller

1.0 SIGNAL DESCRIPTION

Port 0 (P0.0 - P0.7): Port 0 is an 8-bit input only port when used in its default mode. When configured for their alternate function, five of the bits are bi-directional EDAC check bits as shown in Table 1.

Port 1 (P1.0 - P1.7): Port 1 is an 8-bit, quasi-bidirectional, I/O port. All pins are quasi-bidirectional unless the alternate function is selected per Table 2. When the pins are configured for their alternate functions, they act as standard I/O, not quasi-bidirectional.

Port 2 (P2.0 - P2.7): Port 2 is an 8-bit, multifunctional, I/O port. These pins are shared with timer 2 functions, serial data I/O and PWM0 output, per Table 3.

AD0-AD7: The lower 8-bits of the multiplexed address/data bus. The pins on this port are bidirectional during the data phase of the bus cycle.

AD8-AD15: The upper 8-bits of the multiplexed address/data bus. The pins on this port are bidirectional during the data phase of the 16-bit bus cycle. When running in 8-bit bus width, these pins are non-multiplexed, dedicated upper address bit outputs.

HSI: Inputs to the High Speed Input Unit. Four HSI pins are available: HSI.0, HSI.1, HSI.2, and HSI.3. Two of these pins (HSI.2 and HSI.3) are shared with the HSO Unit. Two of these pins (HSI.0 and HSI.1) have alternate functions for Timer 2.

HSO: Outputs from the High Speed Output Unit. Six HSO pins are available: HSO.0, HSO.1, HSO.2, HSO.3, HSO.4, and HSO.5. Pins HSO.4 and HSO.5 are shared with pins HSI.2 and HSI.3 of the HSI Unit respectively.

| Port Pin | Alternate Name | Alternate Function |
|-----------------|----------------|--|
| P0.0-P0.3, P0.6 | ECB0-ECB4 | Error Detection & Correction Check Bits |
| P0.4 P0.5 | | Input Port Pins |
| P0.7 | EXTINT | Setting IOC1.1=1 will allow P0.7 to be used for EXTINT (INT07) |

| Port Pin | Alternate Name | Alternate Function |
|----------|----------------|--|
| P1.0 | P1.0 | I/O Pin |
| P1.1 | P1.1 | I/O Pin |
| P1.2 | P1.2 | I/O Pin |
| P1.3 | PWM1 | Setting IOC3.2=1 enables P1.3 as the Pulse Width Modulator (PWM1) output pin. |
| P1.4 | PWM2 | Setting IOC3.3=1 enables P1.4 as the Pulse Width Modulator (PWM2) output pin. |
| P1.5 | <u>BREQ</u> | Bus Request, output activated when the bus controller has a pending external memory cycle. |
| P1.6 | <u>HLDA</u> | Bus Hold Acknowledge, output indicating the release of the bus. |
| P1.7 | <u>HOLD</u> | Bus Hold, input requesting control of the bus. |

| Port Pin | Alternate Name | Alternate Function |
|----------|----------------|---|
| P2.0 | TXD | Transmit Serial Data. |
| P2.1 | RXD | Receive Serial Data. |
| P2.2 | EXTINT | External interrupt. Clearing IOC1.1 will allow P2.2 to be used for EXTINT (INT07) |
| P2.3 | T2CLK | Timer 2 clock input and Serial port baud rate generator input. |
| P2.4 | T2RST | Timer 2 Reset |
| P2.5 | PWM0 | Pulse Width Modulator output 0 |
| P2.6 | T2UP-DN | Controls the direction of the Timer 2 counter. Logic High equals count down. Logic low equals count up. |
| P2.7 | T2CAPTURE | A rising edge on P2.7 causes the value of Timer 2 to be captured into this register, and generates a Timer 2 Capture interrupt (INT11). |

1.1 Hardware Interface

1.1.1 Interfacing with External Memory

The UT80CRH196KD can interface with a variety of external memory devices. It supports either a fixed 8-bit bus width or a dynamic 8-bit/16-bit bus width, internal READY control for slow external memory devices, a bus-hold protocol that enables external devices to take over the bus, and several bus-control modes. These features provide a great deal of flexibility when interfacing with external memory devices.

1.1.1.1 Chip Configuration Register

The Chip Configuration Register (CCR) is used to initialize the UT80CRH196KD immediately after reset. The CCR is fetched from external address 2018H (Chip Configuration Byte) after removal of the reset signal. The Chip Configuration Byte (CCB) is read as either an 8-bit or 16-bit word depending on the value of the BUSWIDTH pin. The composition of the bits in the CCR are shown in Table 4.

| Bit | Function |
|-----|---|
| 7 | N/A |
| 6 | N/A |
| 5 | IRC1 - Internal READY Mode Control |
| 4 | IRC0 - Internal READY Mode Control |
| 3 | Address Valid Strobe Select (ALE/ADV) |
| 2 | Write Strobe Mode Select (WR and BHE/WRL and WRH) |
| 1 | Dynamic Bus Width Enable |
| 0 | Enable Power Down Mode |

There are 8 configuration bits available in the CCR. However, bits 7 and 6 are not used by the UT80CRH196KD. Bits 5 and 4 comprise the READY mode control which define internal limits for waitstates generated by the READY pin. Bit 3 controls the definition of the ALE/ADV pin for system memory controls while bit 2 selects between the different write modes. Bit 1 selects whether the UT80CRH196KD will use a dynamic 16-bit bus or whether it will be locked in as an 8-bit bus. Finally, Bit 0 enables the Power Down mode and allows the user to disable this mode for protection against inadvertent power downs.

1.1.1.2 Bus Width and Memory Configurations

The UT80CRH196KD external bus can operate as either an 8-bit or 16-bit multiplexed address/data bus (see figure 2). The value of bit 1 in the CCR determines the bus operation. A logic low value on CCR.1 locks the bus controller in 8-bit bus mode. If, however, CCR.1 is a logic high, then the BUSWIDTH signal is used to decide the width of the bus. The bus is 16 bits wide when the BUSWIDTH signal is high, and is 8 bits when the BUSWIDTH signal is low.

1.1.2 Reset

To reset the UT80CRH196KD, hold the $\overline{\text{RESET}}$ pin low for at least 16 state times after the power supply is within tolerance and the oscillator has stabilized. Resets following the power-up reset may be asserted for at least one state time, and the device will turn on a pull-down transistor for 16 state times. This enables the $\overline{\text{RESET}}$ signal to function as the system reset. The reset state of the external I/O is shown in Table 9, and the register reset values are shown in Table 8.

1.1.3 Instruction Set

The instruction set for the UT80CRH196KD is compatible with the industry standard MCS-96 instruction set used on the 8XC196KD.

| Memory Description | Begin | End |
|------------------------------|--------|--------|
| External Memory ¹ | 02080H | 0FFFFH |
| Reserved | 0205EH | 0207FH |
| PTS Vectors | 02040H | 0205DH |
| Upper Interrupt Vectors | 02030H | 0203FH |
| Reserved | 02020H | 0202FH |
| Reserved | 02019H | 0201FH |
| Chip Configuration Byte | 02018H | 02018H |
| Reserved | 02014H | 02017H |
| Lower Interrupt Vectors | 02000H | 02013H |
| External Memory | 00400H | 1FFFH |
| Internal Memory (RAM) | 0001AH | 003FFH |
| Special Function Registers | 00000H | 00019H |

Notes:

1. The first instruction read following reset will be from location 2080h. All other external memory can be used as instruction and/or data memory.

Table 6. Interrupt Vector Sources, Locations, and Priorities

| Number | Interrupt Vector | Source(s) | Interrupt Vector Location | PTS Vector Location | Priority¹ (0 is the Lowest Priority) |
|---|------------------------------|--|----------------------------------|----------------------------|---|
| Special | Unimplemented Opcode | Unimplemented Opcode | 2012h | N/A | N/A |
| Special | Software Trap | Software Trap | 2010h | N/A | N/A |
| INT 15 | NMI ² | NMI | 203Eh | N/A | 15 |
| INT 14 | HSI FIFO Full | HSI FIFO Full | 203Ch | 205Ch | 14 |
| INT 13 | EXTINT 1 ² | Port 2.2 | 203Ah | 205Ah | 13 |
| INT 12 | Timer 2 Overflow | Timer 2 Overflow | 2038h | 2058h | 12 |
| INT 11 | Timer 2 Capture ² | Timer 2 Capture | 2036h | 2056h | 11 |
| INT 10 | HSI FIFO 4 | HSI FIFO Fourth Entry | 2034h | 2054h | 10 |
| INT 9 | Receive | RI Flag ³ | 2032h | 2052h | 9 |
| INT 8 | Transmit | TI Flag ³ | 2030h | 2050h | 8 |
| INT 7 | EXTINT ² | Port 2.2 or Port 0.7 | 200Eh | 204Eh | 7 |
| INT 6 | Serial Port | RI Flag and TI Flag ⁴ | 200Ch | 204Ch | 6 |
| INT 5 | Software Timer | Software Timer 0-3 Timer 2 Reset | 200Ah | 204Ah | 5 |
| INT 4 | HSI.0 ² | HSI.0 Pin | 2008h | 2048h | 4 |
| INT 3 | High Speed Outputs | Events on HSO.0 thru HSO.5 Lines | 2006h | 2046h | 3 |
| INT 2 | HSI Data Available | HSI FIFO Full or HSI Holding Reg. Loaded | 2004h | 2044h | 2 |
| INT 1 | EDAC Bit Error | Single Bit Error Single Bit Error OVF Double Bit Error | 2002h | 2042h | 1 |
| INT 0 | Timer Overflow | Timer 1 or Timer 2 | 2000h | 2040h | 0 |
| <p>All of the previous maskable interrupts can be assigned to the PTS. Any PTS interrupt has priority over all other maskable interrupts.</p> | | | | | |

Notes:

1. The Unimplemented Opcode and Software Trap interrupts are not prioritized. The Interrupt Controller immediately services these interrupts when they are asserted. NMI has the highest priority of all prioritized interrupts. Any PTS interrupt has priority over lower priority interrupts, and over all other maskable interrupts. The standard maskable interrupts are serviced according to their priority number with INT0 has the lowest priority of all interrupts.
2. These interrupts can be configured to function as independent, external interrupts.
3. If the Serial interrupt is masked and the Receive and Transmit interrupts are enabled, the RI flag and TI flag generate separate Receive and Transmit interrupts.
4. If the Receive and Transmit interrupts are masked and the Serial interrupt is enabled, both RI flag and TI flag generate a Serial Port interrupt.

Table 7. SFR Memory Mapping

| Address | HWin 0 Read | HWin 0 Write | HWin 1 | HWin 15 ¹ |
|---------|-----------------|-----------------|--------------------------|----------------------|
| 019H | Stack Pntr (hi) | Stack Pntr (hi) | Stack Pntr (hi) | Stack Pntr (hi) |
| 018H | Stack Pntr (lo) | Stack Pntr (lo) | Stack Pntr (lo) | Stack Pntr (lo) |
| 017H | IOS2 | PWM0_CTRL | PWM2_CTRL | *** |
| 016H | IOS1 | IOC1 | PWM1_CTRL | *** |
| 015H | IOS0 | IOC0 | EDAC-CS ² | *** |
| 014H | WSR | WSR | WSR | WSR |
| 013H | INT_MASK1 | INT_MASK1 | INT_MASK1 | INT_MASK1 |
| 012H | INT_PEND1 | INT_PEND1 | INT_PEND1 | INT_PEND1 |
| 011H | SP_STAT | SP_CON | RESERVED | *** |
| 010H | PORT 2 | PORT 2 | RESERVED | PSW ² |
| 00FH | PORT 1 | PORT 1 | Timer 3(hi) ² | RESERVED |
| 00EH | PORT 0 | BAUD RATE | Timer 3(lo) ² | RESERVED |
| 00DH | Timer 2 (hi) | Timer 2 (hi) | WDT-SCALE ² | T2CAPTURE (hi) |
| 00CH | Timer 2 (lo) | Timer 2 (lo) | IOC3 | T2CAPTURE (lo) |
| 00BH | Timer 1 (hi) | IOC2 | INT_PRI(hi) ² | *** |
| 00AH | Timer 1 (lo) | Watchdog | INT_PRI(lo) ² | *** |
| 009H | INT_PEND | INT_PEND | INT_PEND | INT_PEND |
| 008H | INT_MASK | INT_MASK | INT_MASK | INT_MASK |
| 007H | SBUF (RX) | SBUF (TX) | PTSSRV (hi) | *** |
| 006H | HSI_status | HCO_command | PTSSRV (lo) | *** |
| 005H | HSI_time(hi) | HCO_time (hi) | PTSSEL (hi) | *** |
| 004H | HSI_time (lo) | HCO_time (lo) | PTSSEL (lo) | *** |
| 003H | RESERVED | HSI_mode | RESERVED | *** |
| 002H | RESERVED | RESERVED | RESERVED | RESERVED |
| 001H | Zero_reg (hi) | Zero_reg (hi) | Zero-reg (hi) | Zero_reg (hi) |
| 000H | Zero_reg (lo) | Zero_reg (lo) | Zero_reg (lo) | Zero_reg (lo) |

Notes:

1. For some functions that share a register address in HWindow0, the opposite access type (read/write) is available in HWindow 15 if indicated by the three asterisks (***)
2. These registers are not available in the industry standard 8XC196KD. Therefore, industry standard development software will not recognize these mnemonics, and you will only be able to access them via their physical addresses.

| Table 8: Special Function Register Reset Values | | |
|--|---------------------------|--------------------------------|
| Internal Register | Binary Reset State | Hexadecimal Reset Value |
| Stack Pointer (SP) | XXXX XXXX XXXX XXXX | XXXX |
| I/O Status Register 2 (IOS2) | 0000 0000 | 00 |
| I/O Status Register 1 (IOS1) | 0000 0000 | 00 |
| I/O Status Register 0 (IOS0) | 0000 0000 | 00 |
| Window Select Register (WSR) | 0000 0000 | 00 |
| Interrupt Mask Register 1 (INT_MASK1) | 0000 0000 | 00 |
| Interrupt Pending Register 1 (INT_PEND1) | 0000 0000 | 00 |
| Serial Port Status Register (SP_STAT) | 0000 1011 | 0B |
| Port 2 Register (PORT2) | 110X XXX1 | XX |
| Port 1 Register (PORT1) | 1111 1111 | FF |
| Port 0 Register (PORT0) | XXXX XXXX | XX |
| Timer 2 Value Register (TIMER2) | 0000 0000 0000 0000 | 0000 |
| Timer 1 Value Register (TIMER1) | 0000 0000 0000 0000 | 0000 |
| Interrupt Pending Register (INT_PEND) | 0000 0000 | 00 |
| Interrupt Mask Register (INT_MASK) | 0000 0000 | 00 |
| Receive Serial Port Register (SBUF (RX)) | 0000 0000 | 00 |
| HSI Status Register (HSI_status) | X0X0 X0X0 | XX |
| HSI Time Register (HSI_time) | XXXX XXXX XXXX XXXX | XXXX |
| Zero Register (ZERO_REG) | 0000 0000 0000 0000 | 0000 |
| PWM0 Control Register (PWM0_CTRL) | 0000 0000 | 00 |
| I/O Control Register 1 (IOC1) | 0010 0001 | 21 |
| I/O Control Register 0 (IOC0) | 0000 00X0 | 0X |
| Serial Port Control Register (SP_CON) | 0000 1011 | 0B |
| Baud Rate Register (BAUD_RATE) | 0000 0000 0000 0001 | 0001 |
| I/O Control Register 2 (IOC2) | X00X X000 | XX |
| Watch Dog Timer Register (WATCH-DOG) | 0000 0000 | 00 |

| Table 8: Special Function Register Reset Values | | |
|--|---------------------------|--------------------------------|
| Internal Register | Binary Reset State | Hexadecimal Reset Value |
| Transmit Serial Port Buffer (SBUF (TX)) | 0000 0000 | 00 |
| HSO Command Register (HSO_command) | 0000 0000 | 00 |
| HSO Time Register (HSO_time) | 0000 0000 0000 0000 | 0000 |
| HSI Mode Register (HSI_mode) | 1111 1111 | FF |
| PWM2 Control Register (PWM2_CTRL) | 0000 0000 | 00 |
| PWM1 Control Register (PWM1_CTRL) | 0000 0000 | 00 |
| EDAC Control and Status Register (EDAC_CS) | 0000 0000 | 00 |
| Timer 3 Value Register (TIMER3) | 0000 0000 0000 0000 | 0000 |
| Watchdog Timer Prescaler (WDT_SCALE) | 0000 0000 | 00 |
| I/O Control Register 3 (IOC3) | 1111 0000 | F0 |
| Interrupt Priority Register (INT_PRI) | 0000 0000 | 00 |
| PTS Service Register (PTSSRV) | 0000 0000 0000 0000 | 0000 |
| PTS Select Register (PTSSEL) | 0000 0000 0000 0000 | 0000 |
| Timer 2 Capture Register (T2CAPTURE) | 0000 0000 0000 0000 | 0000 |
| Program Counter (PC) | 0010 0000 1000 0000 | 2080 |
| Chip Configuration Register (CCR) | XX10 1111 | XF |

| Table 9: External I/O Reset State | | | |
|--|-----------------------------------|-------------------------------|-------------------------------|
| External I/O | I/O Function After Reset | I/O State During Reset | I/O State After Reset |
| Address/Data Bus (AD15:0) | Address/Data Bus | Pulled High | Driven Output |
| $\overline{\text{ALE}}$ ADV | ALE | Pulled High | Driven Output |
| $\overline{\text{RD}}$ | $\overline{\text{RD}}$ | Pulled High | Driven Output |
| $\overline{\text{WR}}$ WRL | $\overline{\text{WR}}$ | Pulled High | Driven Output |
| Port 0 (P0.0-P0.3; P0.6) ECB(4:0) | [P0.0-P0.3; P0.6] and ECB(4:0) | Undefined Inputs ¹ | Undefined I/O ^{1,2} |
| Port 0 (P0.4 and P0.5) | P0.4 and P0.5 | Undefined Inputs ¹ | Undefined Inputs ¹ |
| Port 0 (P0.7) EXTINT | P0.7 | Undefined Input ¹ | Undefined Input ¹ |
| NMI | NMI | Pulled Down | Pulled Down |
| HSL0 T2RST | HSL0 | Disabled Input ¹ | Disabled Input ¹ |
| HSL1 T2CLK | HSL1 | Disabled Input ¹ | Disabled Input ¹ |
| HSL2/HSO.4 | Undefined | Disabled I/O ¹ | Disabled I/O ¹ |
| HSL3/HSO.5 | Undefined | Disabled I/O ¹ | Disabled I/O ¹ |
| HSO.0 through HSO.3 | HSO.0-HSO.3 | Pulled Down | Driven Low Outputs |
| Port 1 (P1.0-P1.7) $\overline{\text{PWM1}}$; $\overline{\text{PWM2}}$; $\overline{\text{BREQ}}$; HLDA; HOLD | P1.0-P1.7 | Pulled Up | Pulled Up |
| Port 2 (P2.0) TXD | TXD | Pulled Up | Driven High Output |
| Port 2 (P2.1) RXD | RXD | Undefined Input ¹ | Undefined Input ¹ |
| Port 2 (P2.2) EXTINT | P2.2 and EXTINT | Undefined Input ¹ | Undefined Input ¹ |
| Port 2 (P2.3) T2CLK | P2.3 and T2CLK | Undefined Input ¹ | Undefined Input ¹ |
| Port 2 (P2.4) T2RST | P2.4 | Undefined Input ¹ | Undefined Input ¹ |

| Table 9: External I/O Reset State | | | |
|--|----------------------------|------------------------------|------------------------------|
| External I/O | I/O Function After Reset | I/O State During Reset | I/O State After Reset |
| Port 2 (P2.5) PWM0 | PWM0 | Pulled Down | Driven Low Output |
| Port 2 (P2.6) T2UP-DN | P2.6 | Pulled Up | Pulled Up |
| Port 2 (P2.7) T2CAPTURE | P2.7 and T2CAPTURE | Pulled Up | Pulled Up |
| $\overline{\text{EDACEN}}$ | $\overline{\text{EDACEN}}$ | Undefined Input ¹ | Undefined Input ¹ |
| ECB5 | ECB5 | Undefined I/O ¹ | Undefined I/O ^{1,2} |
| READY | READY | Undefined Input ¹ | Undefined Input ¹ |
| BUSWIDTH | BUSWIDTH | Undefined Input ¹ | Undefined Input ¹ |
| $\overline{\text{BHE}}$ $\overline{\text{WRH}}$ | $\overline{\text{BHE}}$ | Pulled Up | Driven Output |
| CLKOUT | CLKOUT | Driven Output | Driven Output |
| INST | INST | Pulled Down | Driven Output |
| $\overline{\text{RESET}}$ | $\overline{\text{RESET}}$ | Pulled Low by System | Pulled Up |

Notes:

1. These pins must not be left floating. Input voltages must not exceed V_{DD} during power-up.
2. Do not directly tie these pins to V_{DD} or GND; if $\overline{\text{EDACEN}}$ goes low, they may be driven by the UT80CRH196KD and bus contention may occur.

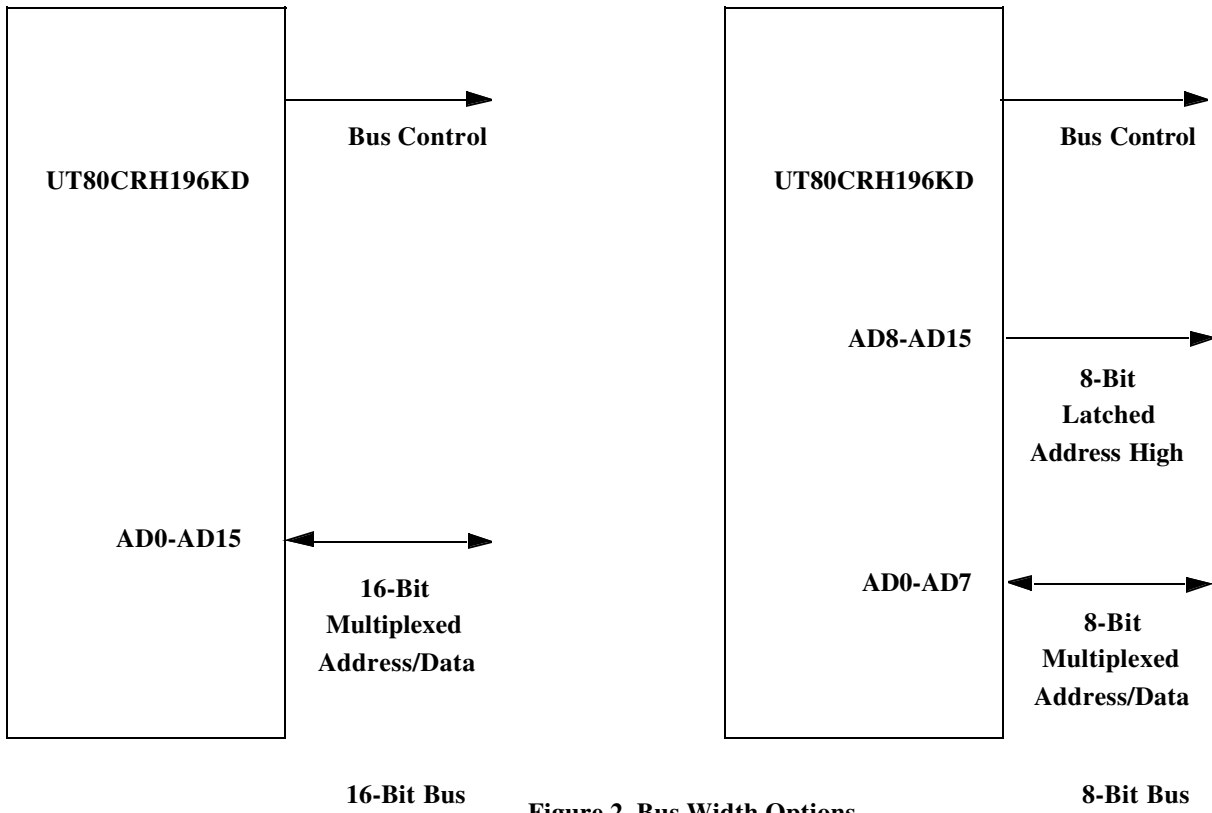

Figure 2. Bus Width Options

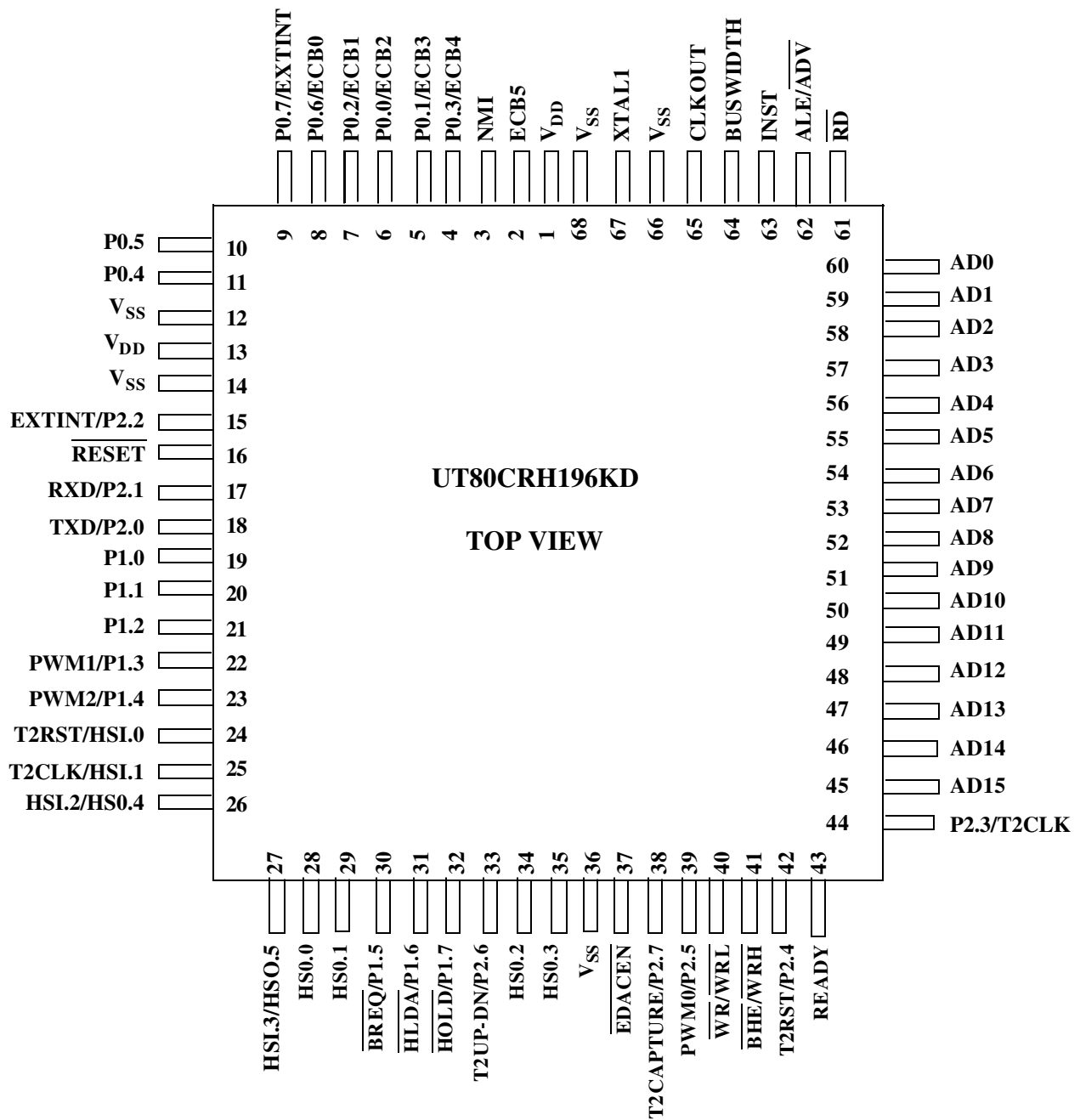

Figure 3. 68-pin Quad Flatpack Package

Legend for I/O fields:

TO = TTL compatible output
 TI = TTL compatible input
 CI = CMOS only input
 TUO = TTL compatible output (internally pulled high)
 TDO = TTL compatible output (internally pulled low)
 TUI = TTL compatible input (internally pulled high)

TDI = TTL compatible input (internally pulled low)
 TB = TTL compatible bidirectional
 TUQ = TTL compatible quasi-bidirectional (internally pulled high)
 TUB = TTL compatible bidirectional (internally pulled high)
 TUBS = TTL compatible bidirectional Schmitt Trigger (internally pulled high)
 PWR = +5V (V_{DD})
 GND = 0V (V_{SS})

Table 10: 68-lead Flat Pack Pin Descriptions

| QFP Pin# | I/O | Name | Active | Description |
|----------|-----|-------------------|--------|--|
| 1 | PWR | V_{DD} | --- | Digital supply voltage (+5V). There are 2 V_{DD} pins, both of which must be connected. |
| 2 | TB | ECB5 ¹ | --- | EDAC Check Bit 5. Asserting the $\overline{\text{EDACEN}}$ pin will cause the error detection and correction engine to pass the EDAC Check Bit 5 through pin 2 of the UT80CRH196KD. |
| 3 | TDI | NMI | High | Non-Maskable Interrupt. A positive transition causes a vector through the NMI interrupt at location 203Eh. Assert NMI for at least 1 state time to guarantee acknowledgment by the interrupt controller. |
| 4 | TI | P0.3 | --- | Port 0 Pin 3. An input only port pin that is read at location 0Eh in HWindow 0. |
| | TB | ECB4 ¹ | --- | EDAC Check Bit 4. Asserting the $\overline{\text{EDACEN}}$ pin will cause the error detection and correction engine to pass the EDAC Check Bit 4 through pin 4 of the UT80CRH196KD. |
| 5 | TI | P0.1 | --- | Port 0 Pin 1. An input only port pin that is read at location 0Eh in HWindow 0. |
| | TB | ECB3 ¹ | --- | EDAC Check Bit 3. Asserting the $\overline{\text{EDACEN}}$ pin will cause the error detection and correction engine to pass the EDAC Check Bit 3 through pin 5 of the UT80CRH196KD. |
| 6 | TI | P0.0 | --- | Port 0 Pin 0. An input only port pin that is read at location 0Eh in HWindow 0. |
| | TB | ECB2 ¹ | --- | EDAC Check Bit 2. Asserting the $\overline{\text{EDACEN}}$ pin will cause the error detection and correction engine to pass the EDAC Check Bit 2 through pin 6 of the UT80CRH196KD. |

Table 10: 68-lead Flat Pack Pin Descriptions

| QFP Pin# | I/O | Name | Active | Description |
|----------|-----|-------------------|--------|---|
| 7 | TI | P0.2 | --- | Port 0 Pin 2. An input only port pin that is read at location 0Eh in HWindow 0. |
| | TB | ECB1 ¹ | --- | EDAC Check Bit 1. Asserting the $\overline{\text{EDACEN}}$ pin will cause the error detection and correction engine to pass the EDAC Check Bit 1 through pin 7 of the UT80CRH196KD. |
| 8 | TI | P0.6 | --- | Port 0 Pin 6. An input only port pin that is read at location 0Eh in HWindow 0. |
| | TB | ECB0 ¹ | --- | EDAC Check Bit 0. Asserting the $\overline{\text{EDACEN}}$ pin will cause the error detection and correction engine to pass the EDAC Check Bit 0 through pin 8 of the UT80CRH196KD. |
| 9 | TI | P0.7 | --- | Port 0 Pin 7. An input only port pin that is read at location 0Eh in HWindow 0. |
| | TI | EXTINT | High | External Interrupt. Setting IOC1.1 = 1 enables pin 9 as the source for the external interrupt EXTINT. A rising edge on this pin will generate EXTINT (INT07, 200Eh). Assert EXTINT for at least 2 state times to ensure acknowledgment by the interrupt controller. During Power Down mode, asserting EXTINT places the chip back into normal operation, even if EXTINT is masked. |
| 10 | TI | P0.5 | --- | Port 0 Pin 5. An input only port pin that is read at location 0Eh in HWindow 0. |
| 11 | TI | P0.4 | --- | Port 0 Pin 4. An input only port pin that is read at location 0Eh in HWindow 0. |
| 12 | GND | V _{SS} | --- | Digital circuit ground (0V). There are 4 V _{SS} pins, all of which must be connected and one additional recommended V _{SS} connection. |
| 13 | PWR | V _{DD} | --- | Digital supply voltage (+5V). There are 2 V _{DD} pins, both of which must be connected. |
| 14 | GND | V _{SS} | --- | Digital circuit ground (0V). There are 4 V _{SS} pins, all of which must be connected and one additional recommended V _{SS} connection. |

Table 10: 68-lead Flat Pack Pin Descriptions

| QFP Pin# | I/O | Name | Active | Description |
|-----------------|------|---------------------------|--------|---|
| 15 | TI | P2.2 | --- | Port 2 Pin 2. An input only port pin that is written at location 10h of HWindow 0. P2.2 will always generate EXTINT1 (INT13, 203Ah) unless masked by the INT_MASK1 register. Assert EXTINT1 for at least 2 state times to guarantee acknowledgment by the interrupt controller. |
| | TI | EXTINT | High | External Interrupt. Setting IOC1.1 = 0 enables pin 15 as the source for the external interrupt EXTINT. A rising edge on this pin will generate EXTINT (INT07, 200Eh). Assert EXTINT for at least 2 state times to ensure acknowledgment by the interrupt controller. During Power Down mode, asserting EXTINT places the chip back into normal operation, even if EXTINT is masked. |
| 16 | TUBS | $\overline{\text{RESET}}$ | Low | Master Reset. The first external reset signal supplied to the UT80CRH196KD must be active for at least 16 state times. All subsequent $\overline{\text{RESET}}$ assertions need only be active for 1 state time because the UT80CRH196KD will continue driving the $\overline{\text{RESET}}$ signal for an additional 16 state times. See section 1.1.2 for more information on the $\overline{\text{RESET}}$ function of the UT80CRH196KD. |
| 17 | TI | P2.1 | --- | Port 2 Pin 1. An input only port pin that is read at location 10h of HWindow 0. Setting SPCON.3 = 0 enables the P2.1 function of pin 17. |
| | TB | RXD | --- | RXD is a bidirectional serial data port. When operating in Serial Modes 1, 2, and 3, RXD receives serial data. When using Serial Mode 0, RXD operates as an input and an open-drain output for data. Setting SPCON.3 = 1 enables the RXD function of pin 17. |
| 18 ² | TUO | P2.0 | --- | Port 2 Pin 0. An output only port pin that is written at location 10h of HWindow 0. Setting IOC1.5 = 0 enables the P2.0 function of pin 18. |
| | TUO | TXD | --- | Transmit Serial Data (TXD). When set to Serial Mode 1, 2, or 3, TXD transmits serial port data. When using Serial Mode 0, TXD is used as the Serial Clock output. Setting IOC1.5 = 1 enables the TXD function of pin 18. |
| | TUI | $\overline{\text{ICT}}$ | Low | In-Circuit Test. The UT80CRH196KD will enter the In-Circuit Test mode if this pin is held low during the rising edge of $\overline{\text{RESET}}$. |

Table 10: 68-lead Flat Pack Pin Descriptions

| QFP Pin# | I/O | Name | Active | Description |
|----------|-----|-------|--------|--|
| 19 | TUQ | P1.0 | --- | Port 1 Pin 0. A quasi-bidirectional port pin that is read and written at location 0Fh of HWindow 0. |
| 20 | TUQ | P1.1 | --- | Port 1 Pin 1. A quasi-bidirectional port pin that is read and written at location 0Fh of HWindow 0. |
| 21 | TUQ | P1.2 | --- | Port 1 Pin 2. A quasi-bidirectional port pin that is read and written at location 0Fh of HWindow 0. |
| 22 | TUQ | P1.3 | --- | Port 1 Pin 3. A quasi-bidirectional port pin that is read and written at location 0Fh of HWindow 0. Setting IOC3.2 = 0 enables the P1.3 function of pin 22. |
| | TUO | PWM1 | --- | Pulse Width Modulator (PWM) Output 1. The output signal will be a waveform whose duty cycle is programmed by the PWM1_CONTROL register, and the frequency is selected by IOC2.2. Setting IOC3.2 = 1 enables the PWM1 function of pin 22. |
| 23 | TUQ | P1.4 | --- | Port 1 Pin 4. A quasi-bidirectional port pin that is read and written at location 0Fh of HWindow 0. Setting IOC3.3 = 0 enables the P1.4 function of pin 23. |
| | TUO | PWM2 | --- | Pulse Width Modulator (PWM) Output 2. The output signal will be a waveform whose duty cycle is programmed by the PWM2_CONTROL register, and the frequency is selected by IOC2.2. Setting IOC3.3 = 1 enables the PWM2 function of pin 23. |
| 24 | TI | HSI.0 | --- | High Speed Input Module, input pin 0. Unless masked, a rising edge on this input will generate the HSI.0 Pin interrupt (INT04, 2008h). Assert the HSI.0 pin for at least 2 state times to ensure acknowledgment by the interrupt controller. Setting IOC0.0 = 1 enables pin 24 as an HSI input, and allows events on this pin to be loaded into the HSI FIFO. |
| | TI | T2RST | High | Timer 2 Reset. A rising edge on the T2RST pin resets Timer 2. To enable the T2RST function of pin 24, set IOC0.3 = 1 and IOC0.5 = 1. |

Table 10: 68-lead Flat Pack Pin Descriptions

| QFP Pin# | I/O | Name | Active | Description |
|-----------------|------------|-------------|---------------|---|
| 25 | TI | HSI.1 | --- | High Speed Input Module, input pin 1. Setting IOC0.2 = 1 enables pin 25 as an HSI input, and allows events on this pin to be loaded into the HSI FIFO. |
| | TI | T2CLK | --- | Timer 2 Clock. Setting IOC0.7 = 1 and IOC3.0 = 0 enables pin 25 to function as the Timer 2 clock source. |
| 26 | TO | HSO.4 | --- | High Speed Output Module, output pin 4. This pin can simultaneously operate in the HSI and HSO modes of operation. As a result, this pin acts as an output that the HSI monitors. Setting IOC1.4 = 1 enables the HSO.4 function of pin 26. |
| | TI | HSI.2 | --- | High Speed Input Module, input pin 2. This pin can simultaneously operate in the HSI and HSO modes of operation. As a result, this pin can monitor events on the HSO. Setting IOC0.4 = 1 enables pin 26 as an HSI input pin, and allows events on this pin to be loaded into the HSI FIFO. |
| 27 | TO | HSO.5 | --- | High Speed Output Module, output pin 5. This pin can simultaneously operate in the HSI and HSO modes of operation. As a result, this pin acts as an output that the HSI monitors. Setting IOC1.6 = 1 enables the HSO.5 function of pin 27. |
| | TI | HSI.3 | --- | High Speed Input Module, input pin 3. This pin can simultaneously operate in the HSI and HSO modes of operation. As a result, this pin can monitor events on the HSO. Setting IOC0.6 = 1 enables pin 27 as an HSI input pin, and allows events on this pin to be loaded into the HSI FIFO. |
| 28 | TDO | HSO.0 | --- | High Speed Output Module, output pin 0. The HSO.0 pin is a dedicated output for the HSO module. |
| 29 | TDO | HSO.1 | --- | High Speed Output Module, output pin 1. The HSO.1 pin is a dedicated output for the HSO module. |

Table 10: 68-lead Flat Pack Pin Descriptions

| QFP Pin# | I/O | Name | Active | Description |
|-----------------|-----|--------------------------|--------|---|
| 30 | TUQ | P1.5 | --- | Port 1 Pin 5. A quasi-bidirectional port pin that is read and written at location 0Fh of HWindow 0. Setting WSR.7 = 0 enables the P1.5 function of pin 30. |
| | TUO | $\overline{\text{BREQ}}$ | Low | Bus Request. The $\overline{\text{BREQ}}$ output signal asserts during a $\overline{\text{HOLD}}$ cycle when the internal bus controller has a pending external memory cycle. During a $\overline{\text{HOLD}}$ cycle, $\overline{\text{BREQ}}$ will not be asserted until the $\overline{\text{HLDA}}$ signal is asserted. Once asserted, $\overline{\text{BREQ}}$ does not deassert until the $\overline{\text{HOLD}}$ signal is released. Setting WSR.7 = 1 enables the $\overline{\text{BREQ}}$ function of pin 30. |
| 31 ² | TUQ | P1.6 | --- | Port 1 Pin 6. A quasi-bidirectional port pin that is read and written at location 0Fh of HWindow 0. Setting WSR.7 = 0 enables the P1.6 function of pin 31. |
| | TUO | $\overline{\text{HLDA}}$ | Low | Bus Hold Acknowledge. The UT80CRH198KD asserts the $\overline{\text{HLDA}}$ signal as a result of another device activating the $\overline{\text{HOLD}}$ signal. By asserting this signal, the UT80CRH196KD is indicating that it has released the bus. Setting WSR.7 = 1 enables the $\overline{\text{HLDA}}$ function of pin 31. |
| 32 | TUQ | P1.7 | --- | Port 1 Pin 7. A quasi-bidirectional port pin that is read and written at location 0Fh of HWindow 0. Setting WSR.7 = 0 enables the P1.7 function of pin 32. |
| | TUI | $\overline{\text{HOLD}}$ | Low | Bus Hold. The $\overline{\text{HOLD}}$ signal is used to request control of the bus by another DMA device. Setting WSR.7 = 1 enables the $\overline{\text{HOLD}}$ function of pin 32. |
| 33 | TUQ | P2.6 | --- | Port 2 Pin 6. A quasi-bidirectional port pin that is read and written at location 10h of HWindow 0. Setting IOC2.1 = 0 enables the P2.6 function of pin 33. |
| | TUI | T2UP-DN | --- | Timer 2 Up or Down. The T2UP-DN pin will dynamically change the direction that Timer 2 counts. T2UP-DN = 1 then Timer 2 counts down. T2UP-DN = 0 then Timer 2 counts up. Setting IOC2.1 = 1 enables the T2UP-DN function of pin 33. When IOC2.1 = 0, Timer 2 will only count up. |

Table 10: 68-lead Flat Pack Pin Descriptions

| QFP Pin# | I/O | Name | Active | Description |
|-----------------|-----|----------------------------|--------|---|
| 34 | TDO | HSO.2 | --- | High Speed Output Module, output pin 2. The HSO.2 pin is a dedicated output for the HSO module. |
| 35 | TDO | HSO.3 | --- | High Speed Output Module, output pin 3. The HSO.3 pin is a dedicated output for the HSO module. |
| 36 | GND | V _{SS} | --- | Digital circuit ground (0V). There are 4 V _{SS} pins, all of which must be connected and one additional recommended V _{SS} connection. |
| 37 | TI | $\overline{\text{EDACEN}}$ | Low | EDAC Enable. Asserting the $\overline{\text{EDACEN}}$ signal activates the error detection and correction engine. This causes the UT80CRH196KD to include ECB(5:0) as the EDAC check bit pins in all external memory cycles. |
| 38 | TUQ | P2.7 | --- | Port 2 Pin 7. A quasi-bidirectional port pin that is read and written at location 10h of HWindow 0. |
| | TUQ | T2CAPTURE | High | Timer 2 Capture. A rising edge on this pin loads the value of Timer 2 into the T2CAPTURE register, and generates a Timer 2 Capture interrupt (INT11, 2036h). Assert the T2CAPTURE signal for at least 2 state times to guarantee acknowledgment by the interrupt controller. Using INT_Mask1.3 controls whether or not a rising edge causes an interrupt. |
| 39 | TDO | P2.5 | --- | Port 2 Pin 5. An output only port pin that is written at location 10h of HWindow 0. Setting IOC1.0 = 0 enables the P2.5 function of pin 39. |
| | TDO | PWM0 | --- | Pulse Width Modulator (PWM) Output 0. The output signal will be a waveform whose duty cycle is programmed by the PWM0_CONTROL register, and the frequency is selected by IOC2.2. Setting IOC1.0 = 1 enables the PWM0 function of pin 39. |
| 40 ² | TUO | $\overline{\text{WR}}$ | Low | Write. The $\overline{\text{WR}}$ signal indicates that an external write is occurring. Activation of this signal only occurs during external memory writes. Setting CCR.2 = 1 enables the $\overline{\text{WR}}$ function of pin 40. |
| | TUO | $\overline{\text{WRL}}$ | Low | Write Low. The $\overline{\text{WRL}}$ signal is activated when writing the low byte of a 16-bit wide word, and is always asserted for 8-bit wide memory writes. Setting CCR.2 = 0 enables the $\overline{\text{WRL}}$ function of pin 40. |

Table 10: 68-lead Flat Pack Pin Descriptions

| QFP Pin# | I/O | Name | Active | Description | | | | | | | | | | | |
|-----------------------|-----------------------|-------------------------------------|--------|---|-----------------------|-----------------------|-------------------------------------|---|---|-----------------------|---|---|----------------------------|---|---|
| 41 | TUO | $\overline{\text{BHE}}$ | Low | Byte High Enable. The assertion of the $\overline{\text{BHE}}$ signal will occur for all 16-bit word writes, and high byte writes in both 8- and 16-bit wide bus cycles. Setting CCR.2 = 1 enables the $\overline{\text{BHE}}$ function of pin 41. | | | | | | | | | | | |
| | TUO | $\overline{\text{WRH}}$ | Low | Write High. The $\overline{\text{WRH}}$ signal is asserted for high byte writes, and word writes for 16-bit wide bus cycles. Additionally, $\overline{\text{WRH}}$ is asserted for all write operations when using an 8-bit wide bus cycle. Setting CCR.2 = 0 enables the $\overline{\text{WRH}}$ function of pin 41. | | | | | | | | | | | |
| 42 | TI | P2.4 | --- | Port 2 Pin 4. An input only port pin that is read at location 10h of HWindow 0. | | | | | | | | | | | |
| | TI | T2RST | High | Timer 2 Reset. Asserting the T2RST signal will reset Timer 2. To enable the T2RST function of pin 42, set IOC0.3 = 1 and IOC0.5 = 0. | | | | | | | | | | | |
| 43 | TI | READY | High | READY input. The READY signal is used to lengthen memory cycles by inserting “wait states” for interfacing to slow peripherals. When the READY signal is high, no “wait states” are generated, and the CPU operation continues in a normal fashion. If READY is low during the falling edge of CLKOUT, the memory controller inserts “wait states” into the memory cycle. “Wait state” generation will continue until a falling edge of CLKOUT detects READY as logically high, or until the number of “wait states” is equal to the number programmed into CCR.4 and CCR.5. Note: The READY signal is only used for external memory accesses, and is functional during the CCR fetch. | | | | | | | | | | | |
| 44 | TI | P2.3 | --- | Port 2 Pin 3. An input only port pin that is read at location 10h of HWindow 0. | | | | | | | | | | | |
| | TI | T2CLK | --- | Timer 2 Clock input. Setting IOC0.7 = 0 and IOC3.0 = 0 enables this pin as the external clock source for Timer 2. <table border="0"> <tr> <td><u>IOC0.7:</u></td> <td><u>IOC3.0:</u></td> <td><u>Timer 2 Clock Source:</u></td> </tr> <tr> <td>X</td> <td>1</td> <td>Internal Clock Source</td> </tr> <tr> <td>0</td> <td>0</td> <td>P2.3 External Clock Source</td> </tr> <tr> <td>1</td> <td>0</td> <td>HSI.1 External Clock Source</td> </tr> </table> | <u>IOC0.7:</u> | <u>IOC3.0:</u> | <u>Timer 2 Clock Source:</u> | X | 1 | Internal Clock Source | 0 | 0 | P2.3 External Clock Source | 1 | 0 |
| <u>IOC0.7:</u> | <u>IOC3.0:</u> | <u>Timer 2 Clock Source:</u> | | | | | | | | | | | | | |
| X | 1 | Internal Clock Source | | | | | | | | | | | | | |
| 0 | 0 | P2.3 External Clock Source | | | | | | | | | | | | | |
| 1 | 0 | HSI.1 External Clock Source | | | | | | | | | | | | | |
| 45 | TUB | AD15 | --- | Bit 15 of the Address/Data bus. This pin is a dedicated address pin when operating with 8-bit wide bus cycles. For 16-bit wide bus cycles, this pin is used as multiplexed address and data. | | | | | | | | | | | |

Table 10: 68-lead Flat Pack Pin Descriptions

| QFP Pin# | I/O | Name | Active | Description |
|-----------------|------------|-------------|---------------|--|
| 46 | TUB | AD14 | --- | Bit 14 of the Address/Data bus. This pin is a dedicated address pin when operating with 8-bit wide bus cycles. For 16-bit wide bus cycles, this pin is used as multiplexed address and data. |
| 47 | TUB | AD13 | --- | Bit 13 of the Address/Data bus. This pin is a dedicated address pin when operating with 8-bit wide bus cycles. For 16-bit wide bus cycles, this pin is used as multiplexed address and data. |
| 48 | TUB | AD12 | --- | Bit 12 of the Address/Data bus. This pin is a dedicated address pin when operating with 8-bit wide bus cycles. For 16-bit wide bus cycles, this pin is used as multiplexed address and data. |
| 49 | TUB | AD11 | --- | Bit 11 of the Address/Data bus. This pin is a dedicated address pin when operating with 8-bit wide bus cycles. For 16-bit wide bus cycles, this pin is used as multiplexed address and data. |
| 50 | TUB | AD10 | --- | Bit 10 of the Address/Data bus. This pin is a dedicated address pin when operating with 8-bit wide bus cycles. For 16-bit wide bus cycles, this pin is used as multiplexed address and data. |
| 51 | TUB | AD9 | --- | Bit 9 of the Address/Data bus. This pin is a dedicated address pin when operating with 8-bit wide bus cycles. For 16-bit wide bus cycles, this pin is used as multiplexed address and data. |
| 52 | TUB | AD8 | --- | Bit 8 of the Address/Data bus. This pin is a dedicated address pin when operating with 8-bit wide bus cycles. For 16-bit wide bus cycles, this pin is used as multiplexed address and data. |
| 53 | TUB | AD7 | --- | Bit 7 of the Address/Data bus. This pin is used as multiplexed address and data for both 8- and 16-bit wide bus cycles. |
| 54 | TUB | AD6 | --- | Bit 6 of the Address/Data bus. This pin is used as multiplexed address and data for both 8- and 16-bit wide bus cycles. |
| 55 | TUB | AD5 | --- | Bit 5 of the Address/Data bus. This pin is used as multiplexed address and data for both 8- and 16-bit wide bus cycles. |
| 56 | TUB | AD4 | --- | Bit 4 of the Address/Data bus. This pin is used as multiplexed address and data for both 8- and 16-bit wide bus cycles. |
| 57 | TUB | AD3 | --- | Bit 3 of the Address/Data bus. This pin is used as multiplexed address and data for both 8- and 16-bit wide bus cycles. |
| 58 | TUB | AD2 | --- | Bit 2 of the Address/Data bus. This pin is used as multiplexed address and data for both 8- and 16-bit wide bus cycles. |
| 59 | TUB | AD1 | --- | Bit 1 of the Address/Data bus. This pin is used as multiplexed address and data for both 8- and 16-bit wide bus cycles. |
| 60 | TUB | AD0 | --- | Bit 0 of the Address/Data bus. This pin is used as multiplexed address and data for both 8- and 16-bit wide bus cycles. |

Table 10: 68-lead Flat Pack Pin Descriptions

| QFP Pin# | I/O | Name | Active | Description |
|-----------------|-----|-------------------------|--------|---|
| 61 ² | TUO | $\overline{\text{RD}}$ | Low | Read. The $\overline{\text{RD}}$ signal is an output to external memory that is only asserted during external memory reads. |
| 62 ² | TUO | ALE | High | Address Latch Enable. The ALE signal is an output to external memory that is only asserted during external memory accesses. ALE is used to specify that valid address information is available on the address/data bus, and signals the start of a bus cycle. ALE is used by an external latch to demultiplex the address from the address/data bus. Setting CCR.3 = 1 enables the ALE function of pin 62. |
| | TUO | $\overline{\text{ADV}}$ | Low | Address Valid. The $\overline{\text{ADV}}$ signal is an output to external memory that is only asserted during external memory accesses. $\overline{\text{ADV}}$ is driven high to specify that valid address information is available on the address/data bus. The $\overline{\text{ADV}}$ signal is held low during the data transfer portion of the bus cycle, and is driven high when the bus cycle completes. $\overline{\text{ADV}}$ is used by an external latch to demultiplex the address from the address/data bus. Setting CCR.3 = 0 enables the $\overline{\text{ADV}}$ function of pin 62. |
| 63 | TDO | INST | High | Instruction Fetch. The INST signal indicates the type of external memory cycle being performed. The INST signal will be high during instruction fetches, and will be low for data fetches. Note: CCB bytes and Interrupt vectors are considered data . |
| 64 | TI | BUSWIDTH | --- | Bus Width. The BUSWIDTH pin dynamically modifies the width of bus cycles. When a high logic value is supplied, the bus width will be set to 16-bits wide. When a low logic level is supplied, the bus width will be set to 8-bits wide. Setting CCR.1 = 1 enables the BUSWIDTH pin. Setting CCR.1 = 0 disables the BUSWIDTH pin. As a result, the UT80CRH196KD will only perform 8-bit wide bus cycles. |
| 65 | TUO | CLKOUT | --- | Clock Output. The CLKOUT signal is the output of the internal clock. This signal has a 50% duty cycle, and runs at 1/2 the frequency of the system clock input to XTAL1. Setting IOC3.1 = 0 will enable the CLKOUT output signal. |
| 66 | GND | V_{SS}^3 | --- | Digital circuit ground (0V). Recommended connection for signal integrity improvement. There are 4 other V_{SS} pins, all of which must be connected. |
| 67 | CI | XTAL1 | --- | External oscillator or clock input to the UT80CRH196KD. The XTAL1 input is fed to the on-chip clock generator. |
| 68 | GND | V_{SS} | --- | Digital circuit ground (0V). There are 4 V_{SS} pins, all of which must be connected and one additional recommended V_{SS} connection. |

Notes:

1. These pins should be pulled high or low when using EDAC (i.e. EDACEN = 0) to prevent the voltages on these pins from floating to the switching threshold of the input buffers during long read cycles.
2. These pins must be high on the rising edge of RESET in order to avoid entering any test modes.
3. This pin is a recommended V_{SS} connection. The remaining 4 V_{SS} pins are required to be tied to the circuit card ground plane.

2.0 RADIATION HARDNESS

The UT80CRH196KD incorporates special design and layout features and is built on UTMC's Commercial RadHard™ silicon. The Commercial RadHard™ silicon is fabricated using a minimally invasive process module, developed by UTMC, that

enhances the total dose radiation hardness of the field and gate oxides while maintaining current density and reliability. In addition, for both greater transient radiation-hardness and latch-up immunity, the UT80CRH196KD is built on epitaxial substrate wafers.

RADIATION HARDNESS DESIGN SPECIFICATIONS

| | | |
|-----------------------------------|-----------|--------------------------------|
| Total Dose | 1.0E5 | rads(Si) |
| LET Threshold | 25 | MeV-cm ² /mg |
| Neutron Fluence | 1.0E14 | n/cm ² |
| Saturated Cross-Section (1Kx8) | 3.66E-7 | cm ² /bit |
| Single Event Upset ¹ | 4.9E-4 | errors/device day ² |
| Single Event Latchup ¹ | LET > 128 | MeV-cm ² /mg |

Notes:

1. Worst case temperature T_A = 25°C for Single Event Upset and 100°C for Single Event Latchup.
2. Adams 90% worst case environment (geosynchronous).

WEIBULL AND DEVICE PARAMETERS FOR ERROR-RATE CALCULATION

| SHAPE PARAMETER | WIDTH PARAMETER | STRUCTURAL CROSS-SECTION | ONSET LET | DEPLETION DEPTH | FUNNEL DEPTH |
|-----------------|-----------------|-----------------------------|-----------------------------|-----------------|--------------|
| 1 | 14 | 3.66E-7cm ² /bit | 14.4MeV-cm ² /mg | 0.8μm | 1.45μm |

3.0 ABSOLUTE MAXIMUM RATINGS¹

(Referenced to V_{SS})

| SYMBOL | PARAMETER | LIMITS | UNITS |
|-------------------------------|---|-------------------------------|-------|
| V _{DD} | DC Supply Voltage | -0.3 to 6.0 | V |
| V _{I/O} ² | Voltage on Any Pin | -0.3 to V _{DD} +0.3V | V |
| T _{STG} | Storage Temperature | -65 to +150 | °C |
| T _J | Maximum Junction Temperature | 175 | °C |
| Θ _{JC} | Thermal Resistance, Junction-to-Case ³ | 16 | °C/W |
| I _I ² | DC Input Current | ±10 | mA |

Notes:

1. Stresses outside the listed absolute maximum ratings may cause permanent damage to the device. This is a stress rating only, and functional operation of the device at these or any other conditions beyond limits indicated in the operational sections of this specification is not recommended. Exposure to absolute maximum rating conditions for extended periods may affect device reliability.
2. These ratings are provided as design guidelines. They are not guaranteed by test or characterization.
3. Test per MIL-STD-883, Method 1012.

4.0 DC ELECTRICAL CHARACTERISTICS (Pre/Post-Radiation)*

($V_{DD} = 5.0V \pm 10\%$) ($T_C = -55^\circ C$ to $+125^\circ C$ for "C" screening and $-40^\circ C$ to $+125^\circ C$ for "W" screening)

| SYMBOL | PARAMETER | CONDITION | MINIMUM | MAXIMUM | UNIT |
|---------------|--|---|---------------|------------|---------|
| V_{IL} | Low-level Input Voltage (except XTAL1, RESET) | | | 0.8 | V |
| V_{IH} | High-level Input Voltage (except XTAL1, RESET) | | 2.2 | | V |
| V_{IH1} | High-level Input Voltage (XTAL1) | | $.7V_{DD}$ | | V |
| V_{IL1} | Low-level Input Voltage (XTAL1) | | | $.3V_{DD}$ | V |
| V_{T+} | Positive Going Threshold RESET | | $.5V_{DD}$ | $.7V_{DD}$ | V |
| V_{T-} | Negative Going Threshold RESET | | $.2V_{DD}$ | $.4V_{DD}$ | V |
| V_H | Typical Range of Hysteresis ⁶ RESET | | .9 | | V |
| V_{OL} | Low-level Output Voltage (CMOS load) (TTL load) | $I_{OL} = 200\mu A$ ⁶ | | 0.3 | V |
| | | $I_{OL} = 4.0mA$ | | 0.4 | V |
| V_{OH} | High-level Output Voltage ⁸ (CMOS load) (Standard outputs) (TTL load) | $I_{OH} = -200\mu A$ ⁶ | $V_{DD} - .3$ | | V |
| | | $I_{OH} = -4.0mA$ | 3.8 | | V |
| I_{OH1} | High-level Output Current ¹ (Open drain outputs with pullups) | $V_{OH} = V_{DD} - .3$ (see Note 6) | -20 | | μA |
| | | $V_{OH} = V_{DD} - .9$ | -60 | | μA |
| I_{IL} | Logical 0 Input Current ² (Test mode entry) | $V_{IN} = V_{IH}$ | -550 | -120 | μA |
| I_{LI} | I/O Leakage Current, standard inputs/outputs in Z state | $V_{IN} = V_{SS}$ or V_{DD} | -5 | +5 | μA |
| I_{LI1} | I/O Leakage Current, with pullups ³ | $V_{IN} = V_{SS}$ | -800 | -150 | μA |
| I_{LI2} | I/O Leakage Current, with pulldowns ⁴ | $V_{IN} = V_{DD}$ | 200 | 1500 | μA |
| C_{IO} | Pin Capacitance ⁶ | @ 1MHZ, 25°C | | 15 | pF |
| A_{IDD} | Active Power Supply Current | Clk@20MHz, typical program flow | | 110 | mA |
| Q_{IDD} | Quiescent Power Supply Current | Unloaded -55° to +25°C | | 20 | μA |
| | | Outputs, +125°C | | 1000 | |
| | | No Clock +25°C post-rad | | 1000 | |
| I_{DDPD} | Power Supply Current in Power Down | No Active I/O, Clk@20MHz | | 6 | mA |
| I_{DDIDLE} | Power Supply Current in Idle Mode | No Active I/O, Clk@20MHZ | | 55 | mA |
| $I_{DDRESET}$ | Power Supply Current in Reset | CLK @20 MHZ, $\overline{RESET} \leq V_{IL}$ | | 65 | mA |
| I_{OS} | Short Circuit output current (except for pins listed in Note 5) ^{6,7} | $V_{DD} = 5.5V$ | -100 | 130 | mA |
| I_{OS1} | Short Circuit output current ^{5,6,7} | $V_{DD} = 5.5V$ | -200 | 250 | mA |

Notes:

* Post-radiation performance guaranteed at 25°C per MIL-STD-883.

1. Open-drain outputs with pullups include Port 1, P2.6 and P2.7.
2. Test modes are entered at the RESET rising edge by applying V_{IH} to one or more of the following pins: TXD, RD, WR, HLDA. To avoid entering a test mode, ensure that these pins remain above V_{IH} at the rising edge of RESET.
3. Inputs/outputs with pullup resistors include: RESET, Port 1, P2.0, P2.6, P2.7, WR, BHE, AD0-15, RD, ALE, CLKOUT.
4. Inputs/outputs will pulldown resistors include: NMI, HS0.0-HS0.3, P2.5, INST.
5. The I_{OS1} spec applies to pins RESET, BHE, RD, CLKOUT.
6. Tested only at initial qualification and after any design or process changes which may affect this characteristic.
7. Not more than one output may be shorted at a time for maximum duration of one second.
8. For standard outputs not covered by IOH1 spec.

5.0 AC CHARACTERISTICS READ CYCLE (Post-Radiation)*

($V_{DD} = 5.0V \pm 10\%$) ($T_C = -55^\circ C$ to $+125^\circ C$ for "C" screening and $-40^\circ C$ to $+125^\circ C$ for "W" screening)

| SYMBOL | PARAMETER | MINIMUM | MAXIMUM | UNIT |
|------------------|-------------------------------------|--------------------|-------------------|------|
| t_{AVYV}^5 | Address VALID to READY setup | | $2T_{OSC} - 30$ | ns |
| t_{YLYH}^5 | Non-READY time | No upper limit | | ns |
| $t_{CLYX}^{1,5}$ | READY hold after CLKOUT low | 0 | $2T_{OSC} - 20$ | ns |
| $t_{LLYX}^{1,5}$ | READY hold after ALE low | T_{OSC} | $3T_{OSC} - 20$ | ns |
| t_{AVGV}^5 | Address valid to BUSWIDTH setup | | $2T_{OSC} - 30$ | ns |
| t_{CLGX}^5 | BUSWIDTH hold after CLKOUT low | 0 | | ns |
| $t_{AVDV}^{2,5}$ | Address valid to input data valid | | $3T_{OSC} - 29$ | ns |
| t_{RLDV}^2 | RD Active to input data valid | 5 (see Note 5) | $T_{OSC} - 26$ | ns |
| t_{CLDV}^5 | CLKOUT low to input data valid | 5 | $T_{OSC} - 26$ | ns |
| t_{RHDZ}^5 | End of RD to input data float | 0 | $T_{OSC} - 10$ | ns |
| t_{RXDX}^5 | Data hold after RD inactive | 0 | $T_{OSC} - 10$ | ns |
| f_{OSC}^5 | Frequency on XTAL1 | 1 (see Note 7) | 20 (see Note 6) | Mhz |
| T_{OSC}^5 | XTAL1 period ($1/f_{OSC}$) | 50 (see Note 6) | 1000 (see Note 7) | ns |
| t_{XHCH} | XTAL1 high to CLKOUT high or low | 0 | +25 | ns |
| t_{CLCL}^6 | CLKOUT cycle time | $2T_{OSC}$ Typical | | ns |
| t_{CHCL}^5 | CLKOUT high period | $T_{OSC} - 10$ | $T_{OSC} + 10$ | ns |
| t_{CLLH} | CLKOUT falling edge to ALE rising | -5 | +15 | ns |
| t_{LLCH}^5 | ALE falling edge to CLKOUT rising | -10 | +10 | ns |
| $t_{LHLH}^{2,6}$ | ALE cycle time | $4T_{OSC}$ Typical | | ns |
| t_{LHL}^5 | ALE high period | $T_{OSC} - 10$ | $T_{OSC} + 15$ | ns |
| t_{AVLL}^5 | Address setup to ALE falling edge | $T_{OSC} - 15$ | | ns |
| t_{LLAX} | Address hold after ALE falling edge | $T_{OSC} - 20$ | $T_{OSC} + 5$ | ns |
| t_{LLRL} | ALE falling edge to RD falling edge | $T_{OSC} - 5$ | $T_{OSC} + 10$ | ns |
| t_{RLCL} | RD low to CLKOUT falling edge | -5 | +10 | ns |
| t_{RLRH}^2 | RD low period | $T_{OSC} - 5$ | | ns |
| $t_{RHLH}^{3,5}$ | RD rising edge to ALE rising edge | $T_{OSC} - 10$ | $T_{OSC} + 10$ | ns |
| t_{RLAZ}^5 | RD low to address float | -5 | +5 | ns |

| | | | | |
|------------------|-------------------------------------|----------------|-----------------|----|
| t_{LLWL}^5 | ALE falling edge to WR falling edge | $T_{OSC} - 10$ | $T_{OSC} + 10$ | ns |
| t_{CLWL} | CLKOUT low to WR falling edge | -5 | +10 | ns |
| t_{QVWH}^2 | Data stable to WR rising edge | $T_{OSC} - 10$ | $T_{OSC} + 10$ | ns |
| t_{CHWH}^5 | CLKOUT high to WR rising edge | -10 | +15 | ns |
| $t_{WLWH}^{2,5}$ | WR low period | $T_{OSC} - 10$ | | ns |
| t_{WHQX}^5 | Data hold after WR rising edge | $T_{OSC} - 10$ | $T_{OSC} + 10$ | ns |
| $t_{WHLH}^{3,5}$ | WR rising edge to ALE rising edge | $T_{OSC} - 10$ | $T_{OSC} + 10$ | ns |
| t_{WHBX}^5 | BHE, INST after WR rising edge | $T_{OSC} - 10$ | $T_{OSC} + 10$ | ns |
| $t_{WHAX}^{4,5}$ | AD8-15 HOLD after WR rising | $T_{OSC} - 25$ | | ns |
| $t_{RH BX}^5$ | BHE, INST after RD rising edge | $T_{OSC} - 10$ | $T_{OSC} + 10$ | ns |
| $t_{RHAX}^{4,5}$ | AD8-15 HOLD after RD rising | $T_{OSC} - 25$ | | ns |
| t_{AVENV}^5 | Address valid to EDACEN valid | | $2T_{OSC} - 30$ | ns |
| t_{LHENV}^5 | EDACEN hold after ALE high | 0 | | ns |
| $t_{AVEV}^{2,5}$ | Address valid to EDAC input valid | | $3T_{OSC} - 29$ | ns |
| t_{RXEX}^5 | EDAC hold after RD inactive | 0 | $T_{OSC} - 10$ | ns |
| $t_{EVWH}^{2,5}$ | EDAC output stable to WR rising | $T_{OSC} - 10$ | $T_{OSC} + 10$ | ns |
| t_{WHEX}^5 | EDAC output hold after WR rising | $T_{OSC} - 10$ | $T_{OSC} + 10$ | ns |

Note:

* Post-radiation performance guaranteed at 25°C per MIL-STD-883 Method 1019 at 1.0E5 rads(Si).

1. If max exceeded, additional wait state occurs.
2. If wait states are used, add $2 T_{OSC} * N$, where N = number of wait states.
3. Assuming back-to-back bus cycles.
4. 8-bit only
5. Tested only at initial qualification, and after any design or process changes which may affect this characteristic.
6. These specs are verified using functional vectors (strobed) only.
7. Low speed tests performed at 5MHz. 1MHz operation is guaranteed by design.

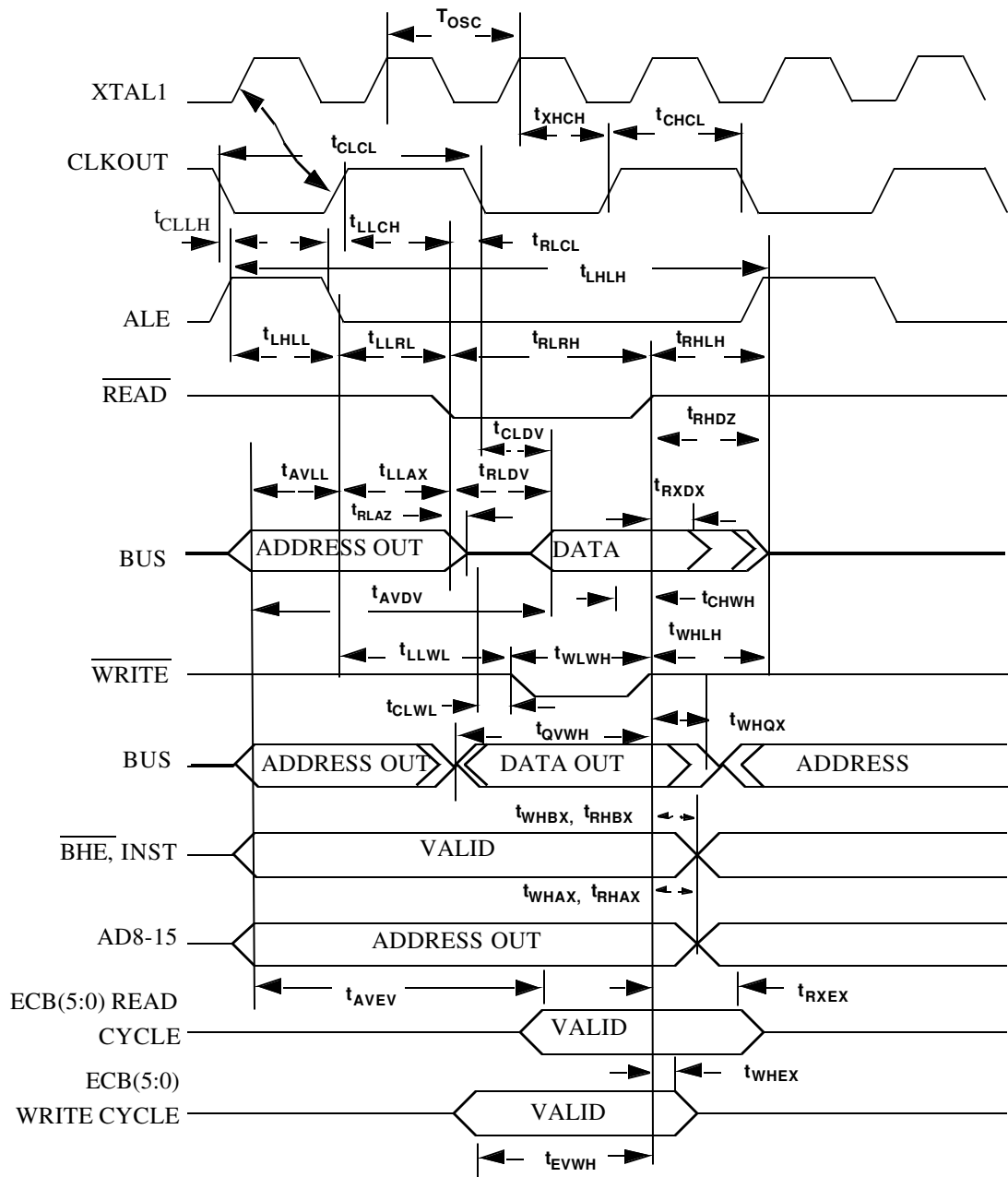

Figure 4. System Bus Timings

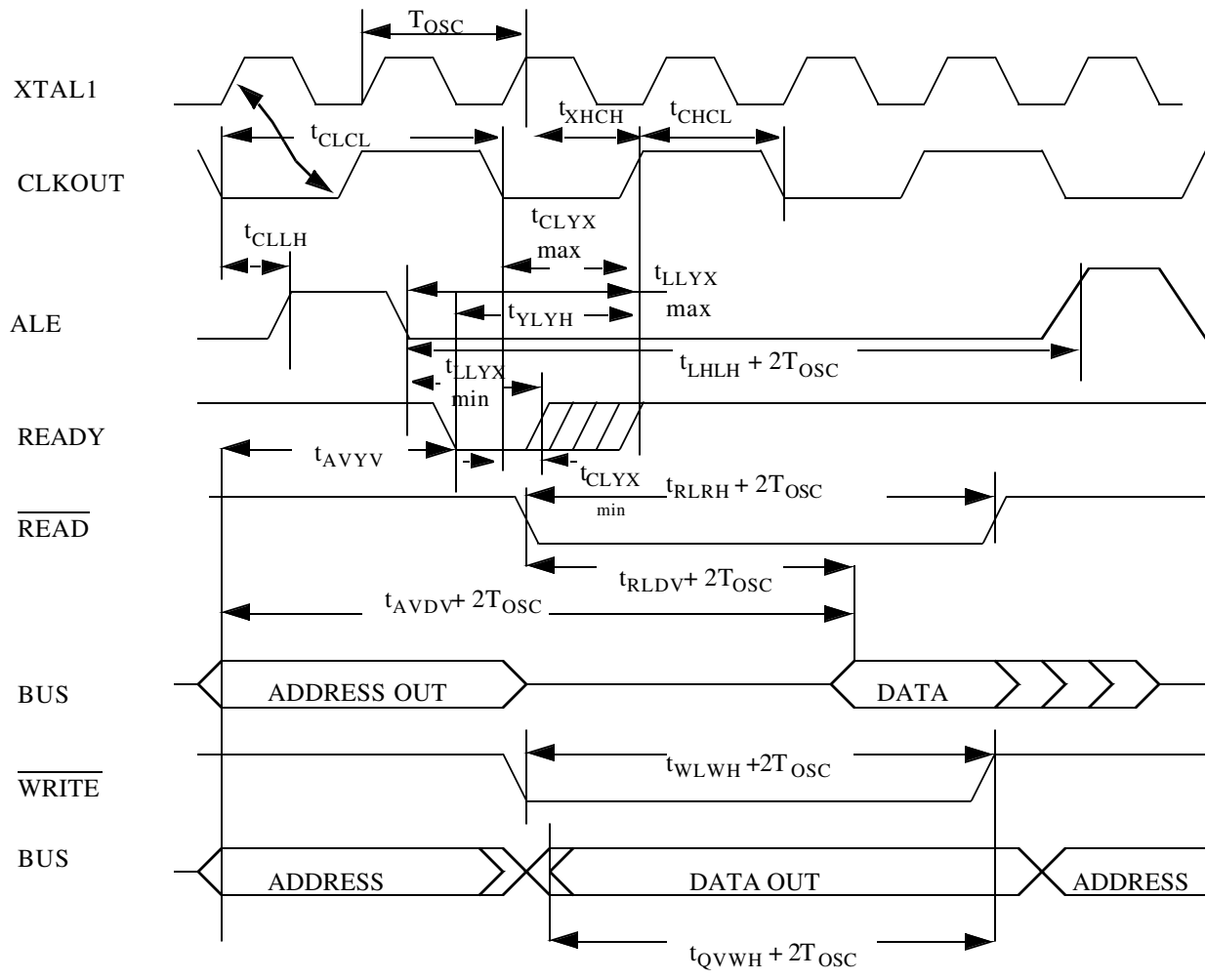

Figure 5. READY Timing (One Wait State)

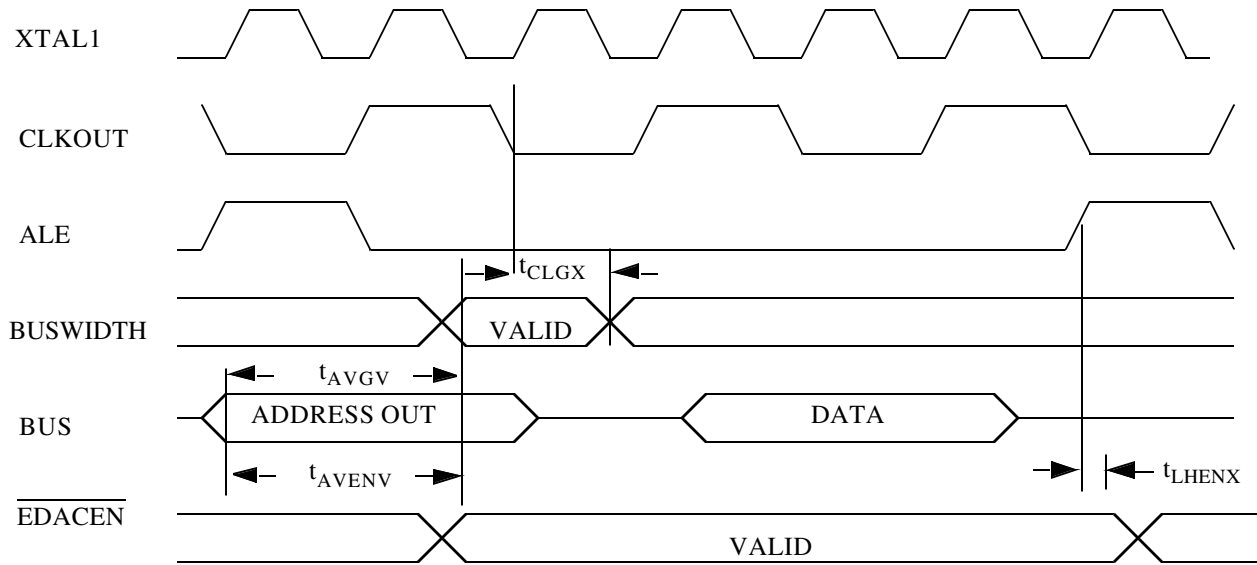

Figure 6. BUSWIDTH and $\overline{\text{EDACEN}}$ Timings

6.0 XTAL1 CLOCK DRIVE TIMING CHARACTERISTICS

| SYMBOL | PARAMETER | MINIMUM | MAXIMUM | UNIT |
|------------|----------------------|------------------------|--------------------------|------|
| f_{OSC} | Oscillator Frequency | 1 ^(note 1) | 20 | MHz |
| T_{OSC} | Oscillator Period | 50 | 1000 ^(note 1) | ns |
| t_{OSCH} | High Time | 17 ^(note 1) | | ns |
| t_{OSCL} | Low Time | 17 ^(note 1) | | ns |
| t_{OSCR} | Rise Time | | 10 ^(note 2) | ns |
| t_{OSCF} | Fall Time | | 10 ^(note 2) | ns |

Note:

1. Tested only at initial qualification, and after any design or process changes which may affect this characteristic.
2. Supplied as a design limit, but not guaranteed or tested.

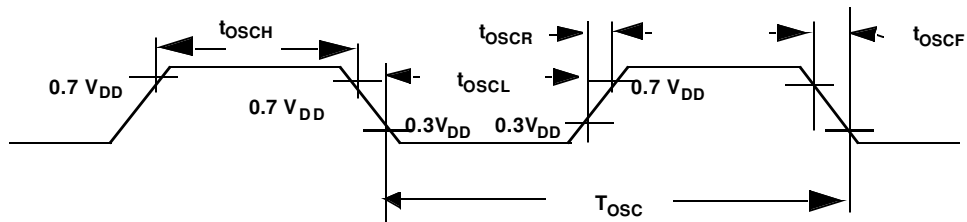

Figure 7. External Clock Drive Timing Waveforms

Table 11. DC Specifications in Hold¹

| DESCRIPTION | MIN | MAX | CONDITIONS |
|--|------|-------|-------------------------------------|
| Pullups on \overline{ADV} , \overline{RD} , \overline{WR} , \overline{WRL} , \overline{BHE} , \overline{ALE} | 6.9K | 36.7K | $V_{DD} = 5.5V$, $V_{IN} = V_{SS}$ |
| Pulldown on \overline{INST} | 3.7K | 27.5K | $V_{DD} = 5.5V$, $V_{IN} = V_{DD}$ |

Note:

1. Tested only at initial qualification, and after any design or process changes which may affect this characteristic.

7.0 HOLD/HLDA Timings

| SYMBOL | PARAMETER | MINIMUM | MAXIMUM | UNIT |
|---------------|---|---------|---------|------|
| t_{HVCH}^1 | \overline{HOLD} Setup | 25 | | ns |
| t_{CLHAL}^1 | \overline{CLKOUT} low to \overline{HLDA} low | -15 | 15 | ns |
| t_{CLBRL}^1 | \overline{CLKOUT} low to \overline{BREQ} low | -15 | 15 | ns |
| t_{HALAZ}^1 | \overline{HLDA} low to address float | | 10 | ns |
| t_{HALBZ}^1 | \overline{HLDA} low to \overline{BHE} , \overline{INST} , \overline{RD} , \overline{WR} driven weakly | | 15 | ns |
| t_{CLHAH}^1 | \overline{CLKOUT} low to \overline{HLDA} high | -15 | 15 | ns |
| t_{CLBRH}^1 | \overline{CLKOUT} low to \overline{BREQ} high | -15 | 15 | ns |
| t_{HAHAX}^1 | \overline{HLDA} high to address no longer float | -15 | | ns |
| t_{HAHBV}^1 | \overline{HLDA} high to \overline{BHE} , \overline{INST} , \overline{RD} , \overline{WR} valid | -10 | | ns |
| t_{CLLH}^1 | \overline{CLKOUT} low to \overline{ALE} high | -5 | 15 | ns |

Note:

1. Tested only at initial qualification, and after any design or process changes which may affect this characteristic.

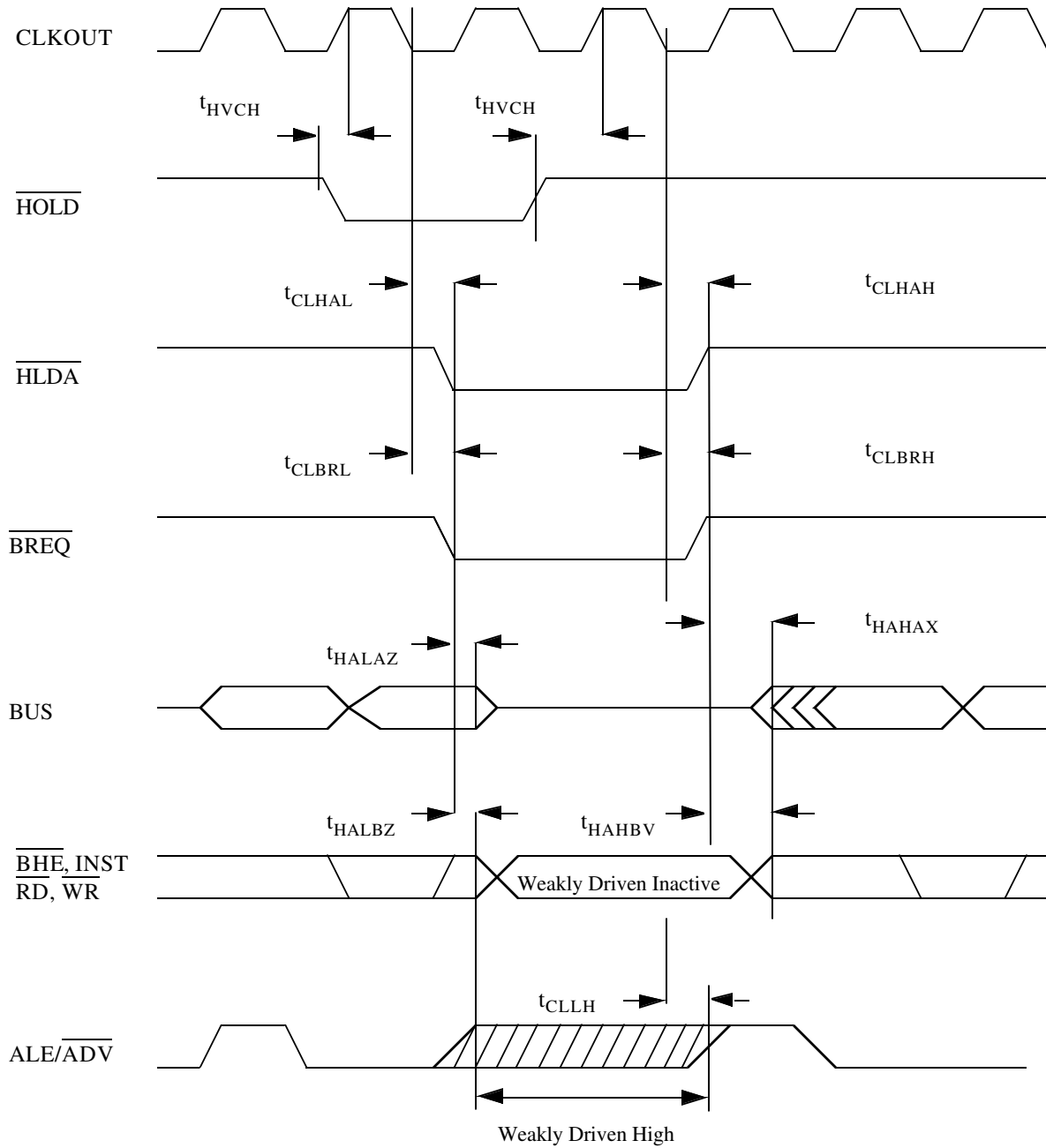

Figure 8. DC Specifications In Hold

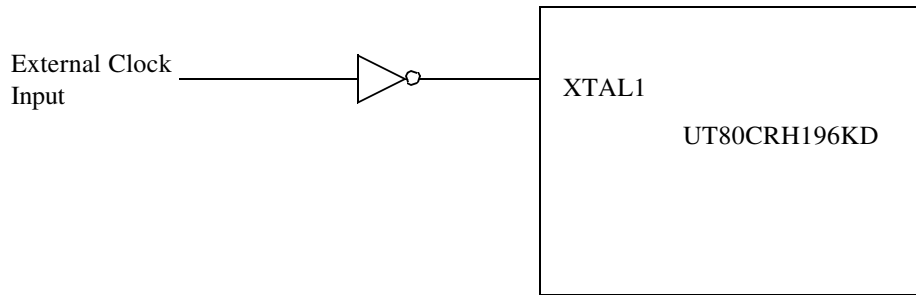
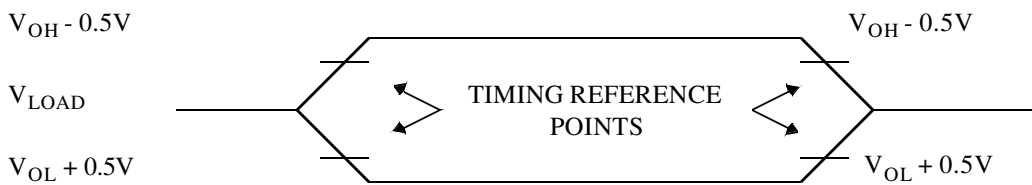

Figure 9. External Clock Connections



AC Testing inputs are driven at V_{DD} for a Logic “1” and $0.0V$ for a Logic “0”. Timing measurements are made at $1.4V$.

Figure 10. AC Testing Input, Output Waveforms



For timing purposes a port pin is no longer floating when it changes to a voltage outside the reference points shown and begins to float when it changes to a voltage inside the reference points shown. $I_{OL} = 4mA$, $I_{OH} = -4mA$.

Figure 11. Float Waveforms

Table 12. Serial Port Timing

| SYMBOL | PARAMETER | MINIMUM | MAXIMUM | UNIT |
|--------------|--|---------------------|------------------|------|
| t_{XLXL}^2 | Serial port clock period ($BRR \geq 8002H$) | 6 T_{OSC} typical | | ns |
| t_{XLXH}^1 | Serial port clock falling edge to rising edge ($BRR \geq 8002H$) | 4 $T_{OSC} - 50$ | 4 $T_{OSC} + 50$ | ns |
| t_{XLXL}^2 | Serial port clock period ($BRR = 8001H$) | 4 T_{OSC} typical | | ns |
| t_{XLXH}^1 | Serial port clock falling edge to rising edge ($BRR = 8001H$) | 2 $T_{OSC} - 50$ | 2 $T_{OSC} + 50$ | ns |
| t_{QVXH}^1 | Output data valid to clock rising edge | 2 $T_{OSC} - 50$ | | ns |
| t_{XHQX}^1 | Output data hold after clock rising edge | 2 $T_{OSC} - 50$ | | ns |
| t_{XHQV}^1 | Next output data valid after clock rising edge | | 2 $T_{OSC} + 50$ | ns |
| t_{DVXH}^1 | Input data setup to clock rising edge | $T_{OSC} + 50$ | | ns |
| t_{XHDX}^1 | Input data hold after clock rising edge | 0 | | ns |
| t_{XHQZ}^1 | Last clock rising to output float | 2 $T_{OSC} - 10$ | 2 $T_{OSC} + 10$ | ns |

Note:

1. Tested only at initial qualification, and after any design or process changes which may affect this characteristic.
2. These specs are verified using functional vectors (strobed) only.

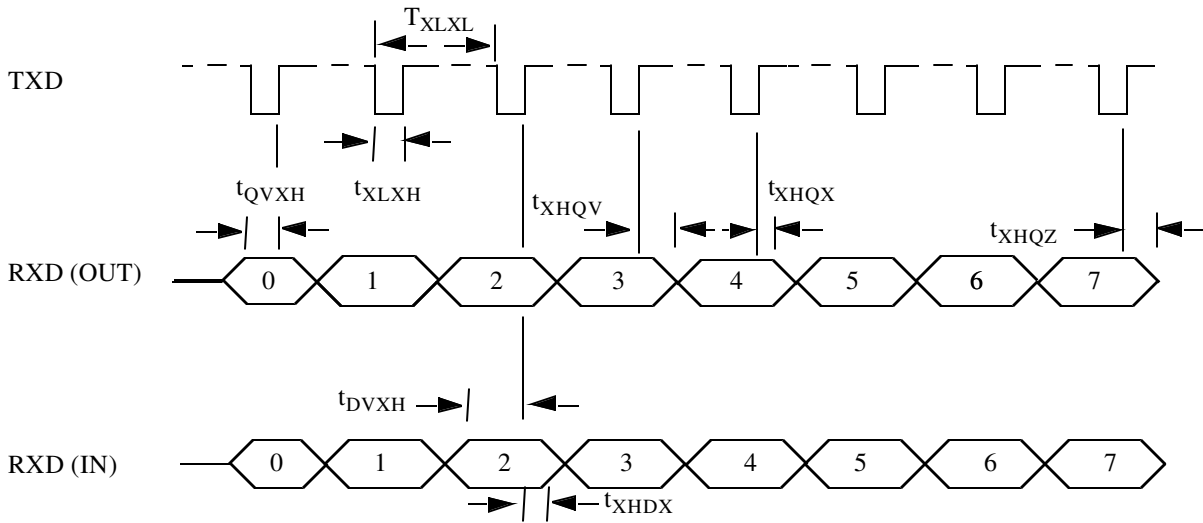

Figure 12. Serial Port Waveform - Shift Register Mode

APPENDIX A

Difference Between Industry Standard and UT80CRH196KD

1.0 UT80CRH196KD DIFFERENCES TO INDUSTRY STANDARD 80C196KD

1.1 Analog to Digital Converter

The Analog to Digital Converter will not be implemented in the UT80CRH196KD.

1.3 Clocking

The XTAL2 output is not used and the UT80CRH196KD expects the input on the XTAL 1 to be a valid digital clock signal. The clock should be stable before reset is removed or Power Down mode is exited. In Power Down mode, a small number of gates will be clocked by the XTAL1 input. The UT80CRH196KD XTAL2 has been replaced with a V_{SS} pin.

1.4 CCB Read after Reset

The CCB fetch after Reset will be a normal fetch as if the chosen bus width is selectable based on the BUSWIDTH input. Systems with an 8-bit wide interface should tie BUSWIDTH to ground. Systems that use BUSWIDTH should perform a normal decode based on the memory configuration of the system. The Industry Standard 80C196KD treats the CCB fetch as an 8-bit fetch (driving the upper 8-bits with address 20H) regardless of the state of BUSWIDTH.

1.5 Internal Program Memory

The UT80CRH196KD does not have internal program memory, and pin 2 (EA) will be ignored for choosing between internal and external program reads. The user may tie this pin to ground for compatibility reasons, unless EDAC is enabled.

1.6 Ports 3 and 4

Since the UT80CRH196KD will not have internal program memory, Ports 3 and 4 will always be used as the multiplexed Address and Data bus. Therefore, these ports will not be configured as I/O ports, and the bidirectional port function of these pins will not be implemented. The pins will only be configured as Address and bidirectional data pins.

1.7 Built in EDAC

The UT80CRH196KD incorporates a built in Error Detection and Correction circuit for external memory reads and writes. The EDAC can be controlled from an external pin. The external pin (Pin 37) can be used to enable or disable this feature interactively. Therefore, different regions of external memory can be assigned to have EDAC as necessary. Additionally, the EDAC check bits will be passed through Port 0, which varies from the industry standard version where Port 0 is an input only port. You can control the interrupt behavior of the EDAC engine by setting bits 6 and 5 of the EDAC Control and Status Register (EDAC_CS). Additionally, reading bit 4 of the EDAC_CS allows you to determine if a double bit error occurred, and

reading bits 3 through 0 of the EDAC_CS Register tells you how many single bit errors have been corrected. The EDAC_CS Register is located at location 15h of HWindow 1.

1.8 Instruction Queue

The instruction queue is eight bytes deep instead of four. The instruction queue also interfaces to the CPU through a 16-bit bus. This configuration will speed up the operation of the UT80CRH196KD.

1.9 WDT and Prescaler

The WDT can now be disabled through the software. The disable feature should allow the user flexibility in using the Watch Dog Timer. The WDT also now has a prescaler which can slow down the counter by a factor of 2^0 to 2^7 . The prescaler will give the user extra time between clears of the WDT. The WDT prescaler (WDT_SCALE) is located at location 0Dh of HWindow 1.

1.10 Interrupt Priority Levels

An additional level of priority encoding is available to the user. Every standard interrupt can be programmed to a higher level of priority. All interrupts in the higher priority will maintain their relative priority, but low priority interrupts can then be programmed for a higher interrupt priority if necessary. The interrupt priority register is 16-bits wide, and maps to the standard interrupts in the same fashion as the INT_MASK and INT_MASK1 registers. The high byte of the Interrupt Priority Register (IN_PRI(hi)) is located at 0Bh of HWindow 1, and the low byte (INT_PRI(lo)) is located at 0Ah of HWindow 1.

1.11 Faster Multiply and Divide

The multiplier and divider have been optimized to perform their operations in fewer state times than in the current version.

1.12 Instructions State Time Reduction

The CPU has been streamlined for faster execution where possible. Examples include 1 state reduction for WORD immediate instructions, 1 state reductions for long indexed instructions, and state reductions for the BMOV instructions.

1.13 STACK_PNTR implemented as Special Function Register

The STACK_PNTR has been implemented as a true Special Function Register instead of in the RAM to allow for quicker pushes and pops. If the stack is not used, the SFR can be used for general purpose data storage.

1.14 Timer3

An additional 16-bit timer/counter has been implemented as a general purpose timer that can be used if Timer1 and Timer 2 are being dedicated to other functional uses. The current value

of Timer3 can be found in locations 0Fh (high byte), and 0Eh (low byte) of HWindow 1.

1.15 Input/Output Pullup/Pulldown Currents

Leakage currents may not meet the industry standard specs due to differently sized weak pullups/pulldowns, during Quasi-Bidirectional and reset/powerdown modes. Refer to specs for I_{L11} and I_{L12} .

1.16 Power-down exit

Pin 37 will not be used to exit power-down mode. Since a digital clock is supplied, no connection between this V_{pp} pin and the power-down circuitry exists.

1.17 Test Mode Entry

Test mode entry will be via four pins: \overline{WR} , \overline{RD} , \overline{ALE} and \overline{HLDA} instead of PWM0.

1.18 Power-on Reset

The UT80CRH196KD will not guarantee the 16-state "pulse stretching" function of a Reset_n pulse applied at power-up. The user must hold Reset_n low until the power and clocks stabilize plus 16-state times, or provide a high to low transition after the power and clocks have stabilized.

1.19 Pullup/Pulldown states

The INST pin will be driven to a weak low during Reset. The ALE signal will be driven to a weak high during Bus Hold.

1.20 Modifying the INT_PEND registers

Two operand rd-modify-wr instructions should be used to modify the INT_PEND registers. Three operand rd-modify-wr instructions may lose an incoming interrupt.

1.21 Serial Port Synchronous Mode

The last clock rising edge to output float time (T_{XHQZ}) is made consistent with the output data hold (T_{XHQX}) time of $2 T_{OSC} \pm 50\text{ns}$. This is longer than the industry standard of $1 T_{OSC}$ max.

1.22 Industry Standard Register Indirect with Auto Increment

The industry standard increments the auto-incremented register after determining the external address instead of at the end of the instruction completion. The UT80CRH196KD performs the auto-increment function at the end of the instruction processing. Please reference the example below that shows the processing difference between the UT80CRH196KD and the industry standard:

ST R0, [R0]+

assume R0 holds the value 1000h before the instruction is executed.

| PROCESSING FLOW FOR THE ST R0, [R0]+ INSTRUCTION | |
|--|---|
| UT80CRH196KD | Industry Standard |
| Address = [R0]; 1000h | Address = [R0]; 1000h |
| R0 ---> Address | R0 = R0+1; 1001h |
| R0 = R0+1; 1001h | R0 ---> Address |
| * The contents in address 1000h are 1000h | * The contents in address 1000h are 1001h |

1.23 AC Timing Differences

There are some AC timing differences between the UT80CRH196KD and the industry standard 80C196KD. Most changes resulted in loosened timing specifications. However, the t_{RHDZ} and t_{RDX} timing specifications were tightened by 5ns. If you have been designing to the industry standard timing specifications, it is important to recognize these two shortened timing specifications.

NOTE: Please visit the UTMC website at www.utmc.com to obtain the latest data sheet updates, application notes, software examples, advisories and erratas for the UT80CRH196KD.

1.24 T2UP-DN Input Signal

Port 2.6 has an alternate function of T2UP-DN enabled by IOC2.1. The industry standard device appears to allow writes into Port 2.6 to directly affect the pin state when in the T2UP-DN mode. (This would allow software control of the T2 direction, but requires ensuring a one (QBD pullup) is written to Port 2.6 if the pin is driven externally). The UT80CRH196KD device is designed to disable the Port 2.6 output when T2UP-DN is enabled. This protects the P2.6/T2UP-DN pin from contention with an externally driven signal, independent of the value written into Port 2.

1.25 NEG 8000h Instruction Operation

The UT80CRH196KD and the industry standard 80C196KD set the N-Flag differently when executing the NEG 8000h instruction. NEG represents the MCS-96 opcode to negate a defined operand (8000h). When the UT80CRH196KD executes the NEG 8000h instruction, the result becomes 8000h with both the N-Flag and the V-Flag set. The industry standard 80C196KD, however, executes the NEG 8000h instruction with a result of 8000h and only the V-Flag set.

1.26 Reserved Opcode EEH

The industry standard 80C196KD using the MCS-96 ISA declares the opcode EEH as a reserved opcode and does not

guarantee the generation of the Unimplemented Opcode Interrupt. The UT80CRH196KD, on the other hand, generates the Unimplemented Opcode Interrupt when the EEH opcode is executed.

1.27 Byte-Wide Reads of the HSI_Time SFR

In order to ensure that the next HSI event is loaded from the FIFO into the HSI holding register, the HSI_TIME special function register must be read as a 16-bit word. Byte-wide reads of the HSI_TIME register will not result in successful loading of the HSI holding register.

1.28 BMOV and BMOVI Maximum Count Limitation

The BMOV and BMOVI instructions provide a powerful method to transferring a large block of data from one location in memory to another. The syntax for the BMOV and BMOVI instructions are as follows:

```
BMOV
    SRC_DEST_REG, CNTREG
BMOVI
    SRC_DEST_REG, CNTREG
```

The SRC_DEST_REG is a long register that contains both addresses for the source and destination blocks. The CNTREG is a 16-bit register specifying the number of transfers being performed. Unlike the industry standard 80C196KD which will accept any 16-bit counter value, the UT80CRH196KD will only accept a value in the range of 0000H to 3FFFH.

1.29 $\overline{\text{BREQ}}$ Activation Prior to $\overline{\text{HLDA}}$

The $\overline{\text{BREQ}}$ signal is used by the UT80CRH196KD to signal a DMA arbiter that it would like to recover access to the memory bus. The UT80CRH196KD, on the other hand, uses the $\overline{\text{HLDA}}$ signal to provide confirmation to the DMA arbiter that the UT80CRH196KD has relinquished control of the memory bus. If the wait state control signal (READY) is high when the UT80CRH196KD decides it will release the bus based on the assertion of the $\overline{\text{HOLD}}$ signal, it will drive the $\overline{\text{BREQ}}$ low one CLKOUT cycle ahead of its assertion of the $\overline{\text{HLDA}}$. Conversely, if the READY signal is low when the UT80CRH196KD decides to relinquish the bus, it will assert $\overline{\text{BREQ}}$ coincidentally with $\overline{\text{HLDA}}$ or some CLKOUT cycle later. The latter behavior is compatible with the industry standard 80C196KD functionality, but the former is unique to the UT80CRH196KD.

1.30 $\overline{\text{HOLD}}$ Must Be Synchronized with $\overline{\text{CLKOUT}}$

The DMA arbiter must synchronize the $\overline{\text{HOLD}}$ signal with the $\overline{\text{CLKOUT}}$ on the UT80CRH196KD. The timing diagram in Figure 8 eludes to the synchronicity of the $\overline{\text{HOLD}}$ signal, but does not clearly identify the outcome if the $\overline{\text{HOLD}}$ signal does not satisfy the timing parameter t_{HVCCH} . If the $\overline{\text{HOLD}}$ setup time is violated on the industry standard 80C196KD, it will require one additional $\overline{\text{CLKOUT}}$ cycle before it recognizes the state change of $\overline{\text{HOLD}}$. Violating the $\overline{\text{HOLD}}$ setup time on the UT80CRH196KD will result in a metastable condition and the UT80CRH196KD's reaction is undefined.

8.0 PACKAGE

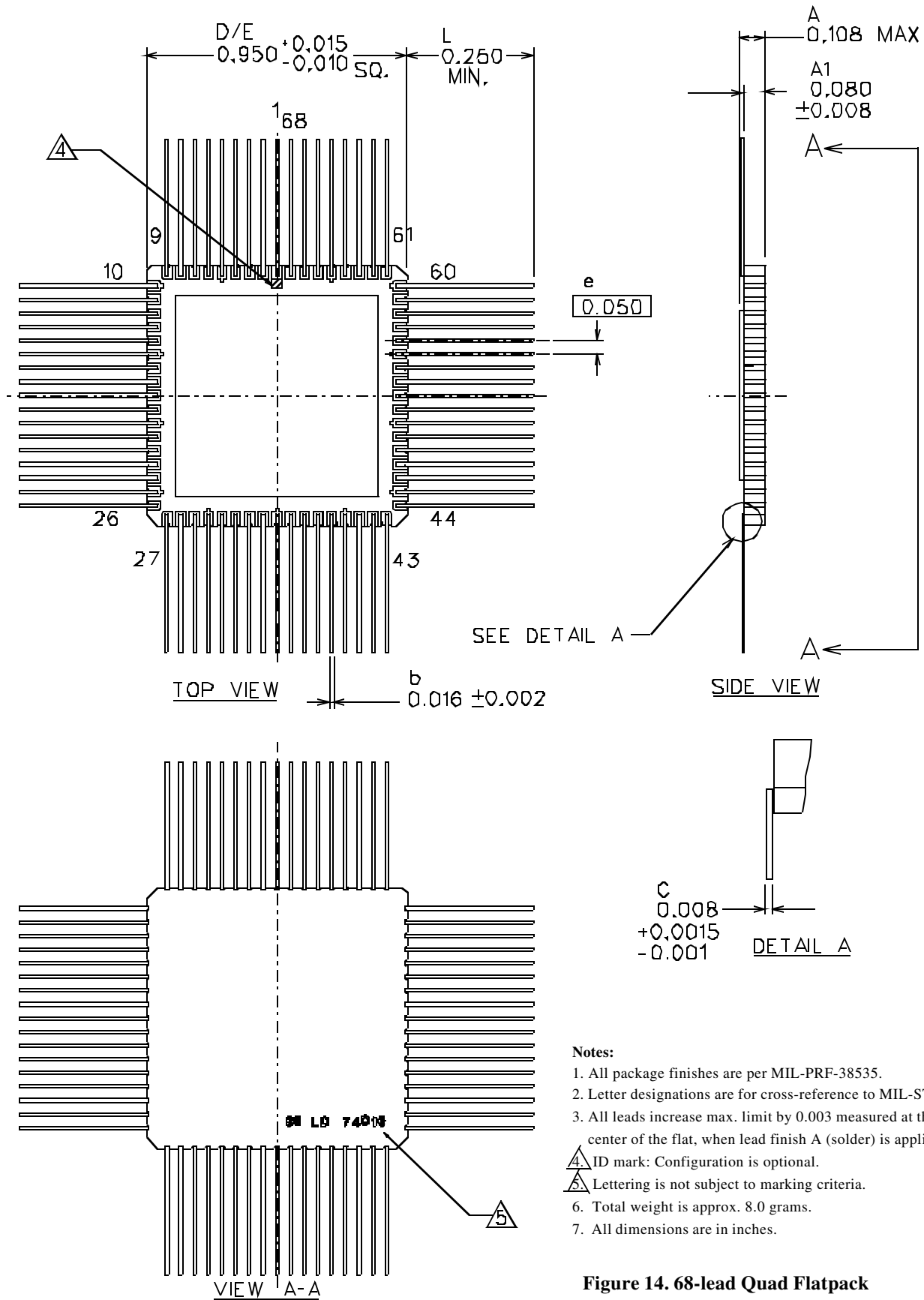

Notes:

1. All package finishes are per MIL-PRF-38535.
2. Letter designations are for cross-reference to MIL-STD-1835.
3. All leads increase max. limit by 0.003 measured at the center of the flat, when lead finish A (solder) is applied.
4. ID mark: Configuration is optional.
5. Lettering is not subject to marking criteria.
6. Total weight is approx. 8.0 grams.
7. All dimensions are in inches.

Figure 14. 68-lead Quad Flatpack

ORDERING INFORMATION

UT80CRH196KD 16-Bit Microcontroller: SMD

5962 R 98583 ** * * *

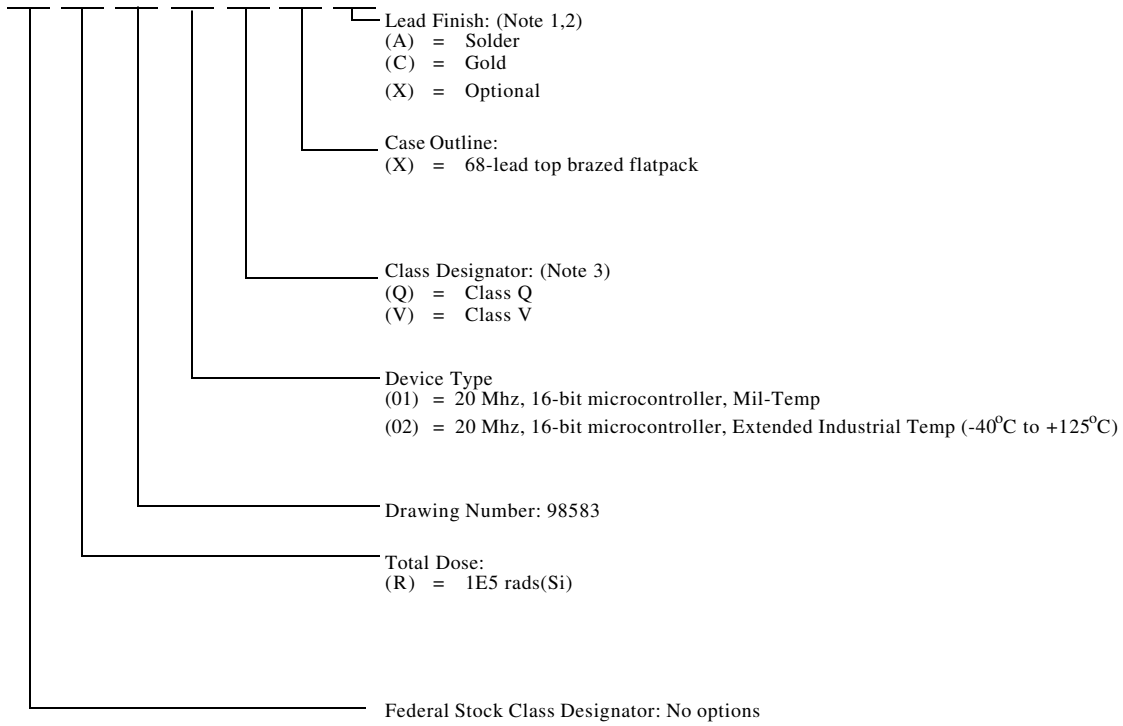

Notes:

1. Lead finish (A, C, or X) must be specified.
2. If an "X" is specified when ordering, part number will match the lead finish and will be either "A" (solder) or "C" (gold).
3. Total dose radiation must be specified when ordering. QML V is not available without radiation testing.

UT80CRH196KD Microcontroller

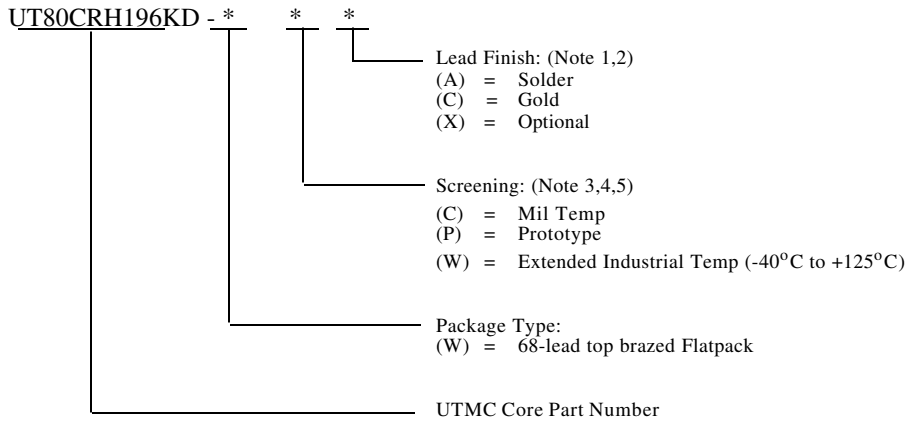

Notes:

1. Lead finish (A,C, or X) must be specified.
2. If an "X" is specified when ordering, then the part number will match the lead finish and will be either "A" (solder) or "C" (gold).
3. Military Temperature Range flow per UTMC Manufacturing Flows Document. Devices are tested -55°C, room temp, and 125°C. Radiation neither tested nor guaranteed.
4. Prototype flow per UTMC Manufacturing Flows Document Tested at 25°C only. Lead finish is gold only. Radiation is neither tested nor guaranteed.
5. Extended Industrial Temperature Range Flow per UTMC Manufacturing Flows Document. Devices are tested at -40°C, room temp, and +125°C. Radiation is neither tested nor guaranteed.

Notes

Notes

Aeroflex Colorado Springs - Datasheet Definition

Advanced Datasheet - Product In Development

Preliminary Datasheet - Shipping Prototype

Datasheet - Shipping QML & Reduced Hi-Rel

COLORADO

Toll Free: 800-645-8862
Fax: 719-594-8468

INTERNATIONAL

Tel: 805-778-9229
Fax: 805-778-1980

NORTHEAST

Tel: 603-888-3975
Fax: 603-888-4585

SE AND MID-ATLANTIC

Tel: 321-951-4164
Fax: 321-951-4254

WEST COAST

Tel: 949-362-2260
Fax: 949-362-2266

CENTRAL

Tel: 719-594-8017
Fax: 719-594-8468

www.aeroflex.com/RadHard
info-ams@aeroflex.com

Aeroflex Colorado Springs, Inc. (Aeroflex) reserves the right to make changes to any products and services herein at any time without notice. Consult Aeroflex or an authorized sales representative to verify that the information in this data sheet is current before using this product. Aeroflex does not assume any responsibility or liability arising out of the application or use of any product or service described herein, except as expressly agreed to in writing by Aeroflex; nor does the purchase, lease, or use of a product or service from Aeroflex convey a license under any patent rights, copyrights, trademark rights, or any other of the intellectual rights of Aeroflex or of third parties.



Our passion for performance is defined by three attributes represented by these three icons: solution-minded, performance-driven and customer-focused