

Low Noise Zener Diode Series

1N4099UR-1 thru 1N4135UR-1 &
1N4614UR-1 thru 1N4627UR-1

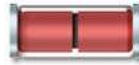
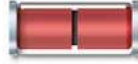

Features

- Available in JAN, JANTX, JANTXV and JANS per MIL-PRF-19500/435
- Tight tolerances available in plus or minus 2% or 1% with C or D suffix respectively.
- 500 mW power handling
- Hermetically sealed MELF DO-213 package.
- Also available in axial-leaded glass DO-35 style package.

Maximum Ratings

Operating & Storage Temperature: -65 to +175 °C

Thermal Resistance: 250 °C/W

Steady-State Power: 0.5 watts

Forward Voltage @200 MA: 1.1 V

Electrical Specifications @ +25 °C (Unless Otherwise Specified)

JEDEC TYPE No. (Note 1)	Normal Zener Voltage	Zener Test Current	Maximum Zener Impedance	Maximum Reverse Current		Maximum Noise Density	Maximum Zener Current
	$V_z @ I_{ZT}$	I_{ZT}	Z_{ZT}	$I_R @ V_R$	V_R	$N_D @ I_{ZT}$	I_{ZM}
	Volts	mA	Ohms	mA	Volts	$\mu V / \sqrt{Hz}$	mA
1N4614UR-1	1.8	250	1200	7.5	1	1	120
1N4615UR-1	2.0	250	1250	5.0	1	1	110
1N4616UR-1	2.2	250	1300	4.0	1	1	100
1N4617UR-1	2.4	250	1400	2.0	1	1	95
1N4618UR-1	2.7	250	1500	1.0	1	1	90
1N4619UR-1	3.0	250	1600	0.8	1	1	87
1N4620UR-1	3.3	250	1650	7.5	1.5	1	85
1N4621UR-1	3.6	250	1700	7.5	2	1	83
1N4622UR-1	3.9	250	1650	5.0	2	1	80
1N4623UR-1	4.3	250	1600	4.0	2	1	77
1N4624UR-1	4.7	250	1550	10.0	2	1	75
1N4625UR-1	5.1	250	1500	10.0	3	2	70
1N4626UR-1	5.6	250	1400	10.0	4	4	65
1N4627UR-1	6.2	250	1200	10.0	5	5	61
1N4099UR-1	6.8	250	200	10.0	5.17	40	56
1N4100UR-1	7.5	250	200	10.0	5.70	40	51
1N4101UR-1	8.2	250	200	1.0	6.24	40	46
1N4102UR-1	8.7	250	200	1.0	6.61	40	44
1N4103UR-1	9.1	250	200	1.0	6.92	40	42
1N4104UR-1	10	250	200	1.0	7.60	40	38
1N4105UR-1	11	250	200	0.05	8.44	40	35
1N4106UR-1	12	250	200	0.05	8.12	40	32
1N4107UR-1	13	250	200	0.05	9.857	40	29
1N4108UR-1	14	250	200	0.05	10.65	40	27
1N4109UR-1	15	250	100	0.05	11.40	40	25
1N4110UR-1	16	250	100	0.05	12.15	40	24
1N4111UR-1	17	250	100	0.05	12.92	40	22
1N4112UR-1	18	250	100	0.05	13.67	40	21
1N4113UR-1	19	250	150	0.05	14.44	40	20
1N4114UR-1	20	250	150	0.01	15.20	40	19
1N4115UR-1	22	250	150	0.01	16.72	40	17
1N4116UR-1	24	250	150	0.01	18.25	40	16
1N4117UR-1	25	250	150	0.01	19.00	40	15
1N4118UR-1	27	250	150	0.01	20.45	40	14
1N4119UR-1	29	250	200	0.01	21.28	40	14
1N4120UR-1	30	250	200	0.01	22.80	40	13
1N4121UR-1	33	250	200	0.01	25.08	40	12
1N4122UR-1	36	250	200	0.01	27.38	40	11
1N4123UR-1	39	250	200	0.01	29.65	40	9.8
1N4124UR-1	43	250	250	0.01	32.65	40	8.9
1N4125UR-1	47	250	250	0.01	35.75	40	8.1
1N4126UR-1	51	250	300	0.01	38.76	40	7.5
1N4127UR-1	56	250	300	0.01	42.60	40	6.7
1N4128UR-1	60	250	400	0.01	45.60	40	6.4
1N4129UR-1	62	250	500	0.01	47.10	40	6.1
1N4130UR-1	68	250	700	0.01	51.68	40	5.6
1N4131UR-1	75	250	700	0.01	57.00	40	5.1
1N4132UR-1	82	250	800	0.01	62.32	40	4.6
1N4133UR-1	87	250	1000	0.01	66.12	40	4.4
1N4134UR-1	91	250	1200	0.01	69.16	40	4.2
1N4135UR-1	100	250	1500	0.01	76.00	40	3.0

NOTE 1: The JEDEC type numbers shown with no suffix have a standard tolerance of $\pm 5\%$ on the nominal Zener voltage; suffix C is used to identify $\pm 2\%$; and suffix D is used to identify $\pm 1\%$ tolerance. V_z is measured with the diode in thermal equilibrium in 25°C still air.



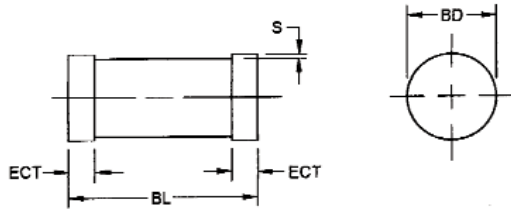

Symbol	Dimensions			
	Inch		Millimeters	
	Min	Max	Min	Max
BD	0.94	.106	2.39	2.67
BL	.189	.206	4.80	5.21
ECT	.016	.022	0.41	0.55
S	.001 min		0.03 min	

LEADED DESIGN DATA

CASE: DO-213AA, Hermetically sealed glass case.
(MELF, SOD-80, LL34)

LEAD FINISH: Tin / Lead

THERMAL RESISTANCE: ($R_{\theta JEC}$): 100 °C/W maximum at L = 0 inch

THERMAL IMPEDANCE: ($Z_{\theta JX}$): 25 °C/W maximum

POLARITY: Diode to be operated with the banded (cathode) end positive.

MOUNTING POSITION: Any.

Circuits & Graphs

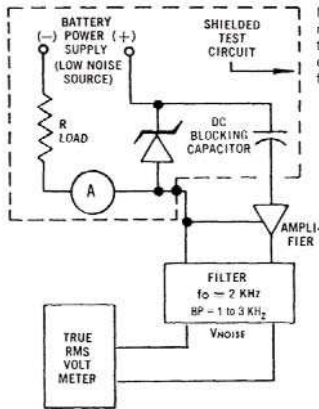

FIGURE 1
NOISE DENSITY MEASUREMENT CIRCUIT

Noise density, (N_n) is specified in microvolt-rms per square-root-hertz. Actual measurement is performed using a 1 KHz to 3 KHz frequency bandpass filter at a constant Zener test current (I_T) AT 25°C ambient temperature. N_n is calculated from the formula.

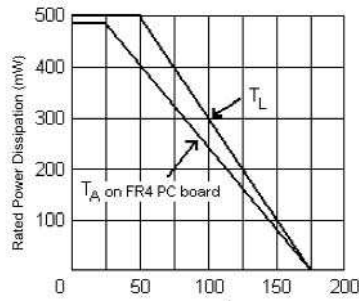

FIGURE 2 – POWER DERATING CURVE

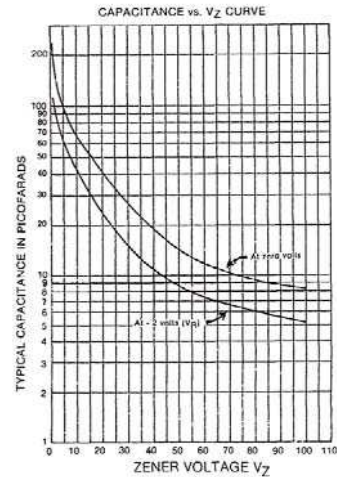

FIGURE 3
CAPACITANCE vs. ZENER VOLTAGE
(TYPICAL)

Aeroflex / Metelics, Inc.

975 Stewart Drive,
Sunnyvale, CA 94085
Tel: (408) 737-8181
Fax: (408) 733-7645

Sales: 888-641-SEMI (7364)

Hi-Rel Components

9 Hampshire Street,
Lawrence, MA 01840
Tel: (603) 641-3800
Fax: (978) 683-3264

www.aeroflex.com/metelics-hirelcomponents

54 Grenier Field Road,
Londonderry, NH 03053
Tel: (603) 641-3800
Fax: (603)-641-3500

ISO 9001: 2008 certified companies

www.aeroflex.com/metelics metelics-sales@aeroflex.com

Aeroflex / Metelics, Inc. reserves the right to make changes to any products and services herein at any time without notice. Consult Aeroflex or an authorized sales representative to verify that the information in this data sheet is current before using this product. Aeroflex does not assume any responsibility or liability arising out of the application or use of any product or service described herein, except as expressly agreed to in writing by Aeroflex; nor does the purchase, lease, or use of a product or service from Aeroflex convey a license under any patent rights, copyrights, trademark rights, or any other of the intellectual rights of Aeroflex or of third parties.

Copyright 2012 Aeroflex / Metelics. All rights reserved.



Our passion for performance is defined by three attributes represented by these three icons: solution-minded, performance-driven and customer-focused.