

THE INFORMATION CONTAINED HEREIN IS CONSIDERED "PROPRIETARY" TO BEL FUSE INC. AND SHALL NOT BE COPIED, REPRODUCED OR DISCLOSED WITHOUT THE WRITTEN APPROVAL OF BEL FUSE INC.



LED POLARITY			
PIN 12	PIN 11	PIN 10	COLOR
-	+	/	GREEN
/	+	-	ORANGE

ELECTRICAL CHARACTERISTICS @ 25°C

URNS RATIO

TX 1CT : 1CT ±2%
 RX 1CT : 1CT ±2%

CL @ 100kHz/100mVRMS

8mA DC BIAS 400µH MIN.

INS. LOSS

1MHz TO 100MHz -1.0 dB MAX

RETURN LOSS (TX/RX)

1.0 THRU 30 MHz -18 dB MIN
 30.1 THRU 60 MHz -18+20Log(f/30MHz)dB MIN
 60.1 THRU 80 MHz -12 dB MIN

CROSSTALK

500kHz - 100MHz -35 dB MIN

CM TO CM REJ

100kHz - 100MHz -30 dB MIN

CM TO DM REJ

100kHz - 100MHz -35 dB MIN

HIPOT (Isolation Voltage):

1500 Vrms or 2250VDC

LED

VF (FORWARD VOLTAGE) IF=20mA GREEN 2.2V TYP.
 ORANGE 2.0V TYP.

λD (DOMINANT WAVELENGTH) IF=20mA GREEN 565nm TYP.
 ORANGE 610nm TYP.

NOTES:

SCHEMATIC & ELECTRICAL CHARACTERISTICS ARE IDENTICAL FOR PORT 1 & PORT 2.

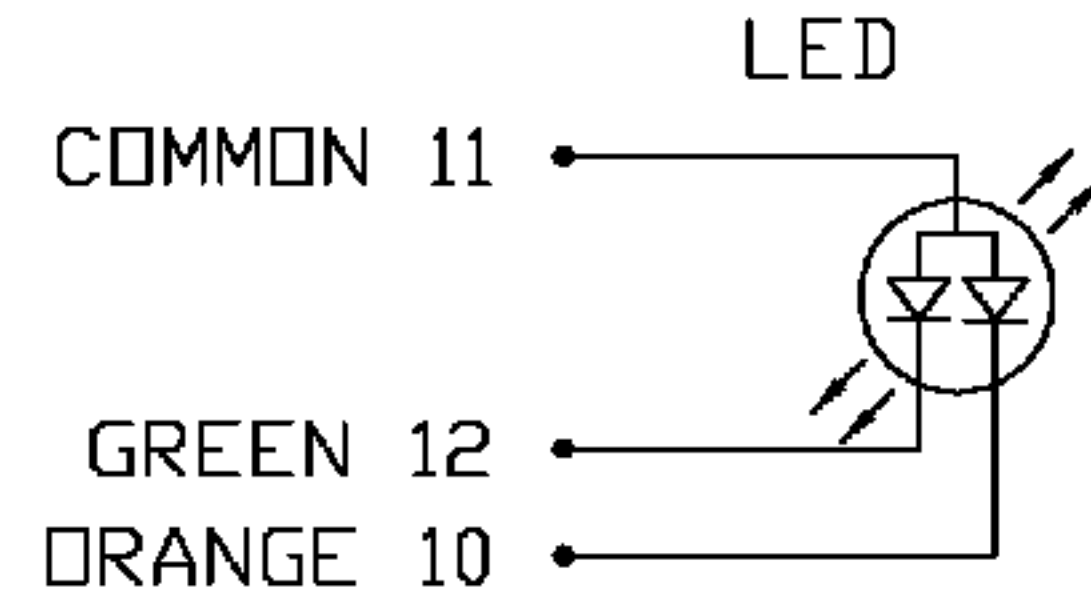

SCHEMATIC

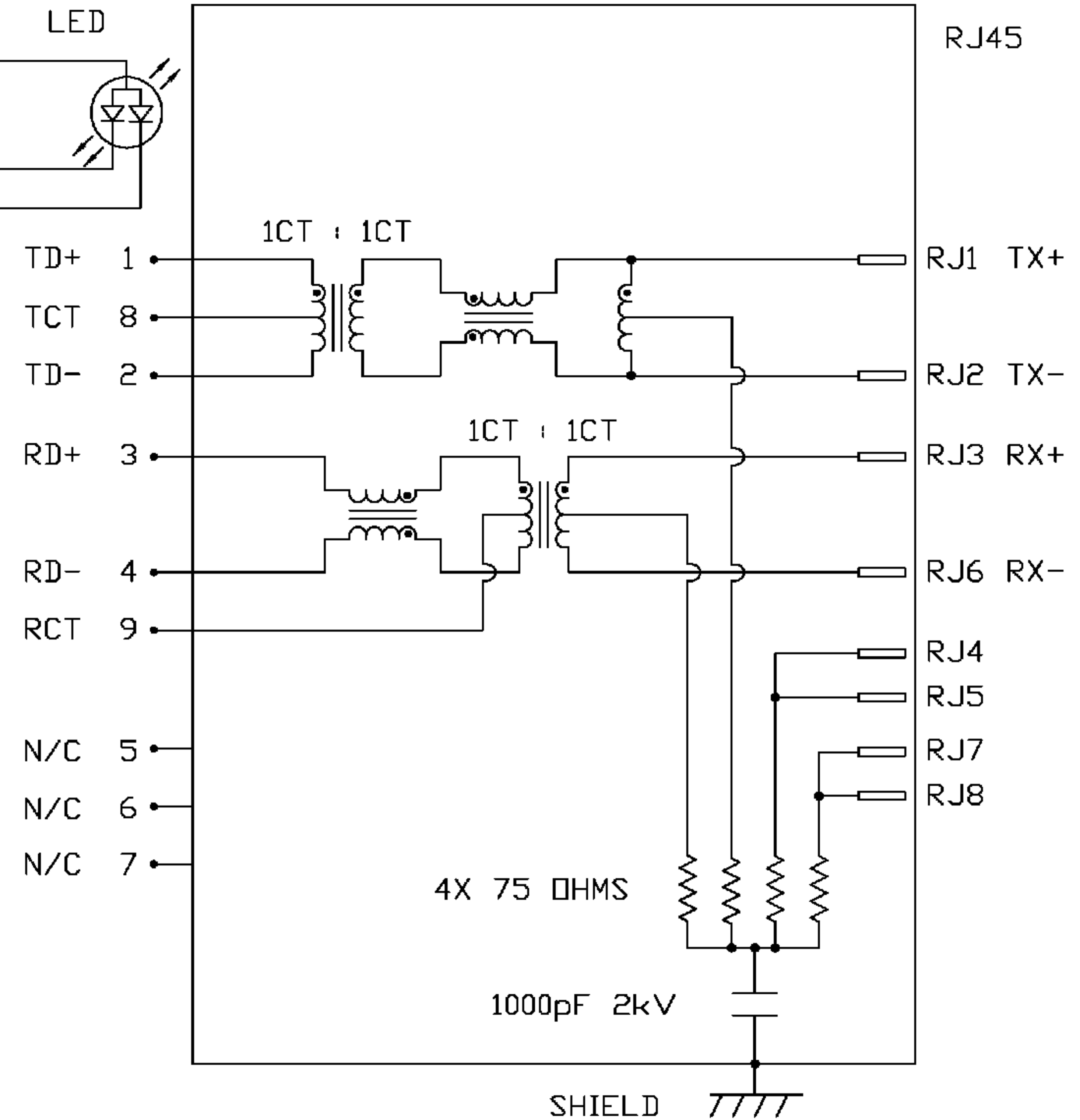

ORIGINATED BY CHUNG	DATE 06-12-06	TITLE 2X1 MagJack® (5 Cores, 10/100, with LED)	PART NO. / DRAWING NO. 08432B1T70-F	STANDARD DIM. TOL. IN INCH .X .XX .XXX	[] METRIC DIM. AS REFERENCE UNIT : INCH [mm] SCALE : N/A	REV. : A SIZE : A4 PAGE : 2	 COMPONENTS FOR A CONNECTED PLANET
DRAWN BY DE	DATE 06-12-06	FILE NAME 08432B1T70-FA.DWG					
<p style="text-align: center;">This document is electronically generated. This is a controlled copy if used internally</p>							

THE INFORMATION CONTAINED HEREIN IS CONSIDERED "PROPRIETARY" TO BEL FUSE INC. AND SHALL NOT BE COPIED, REPRODUCED OR DISCLOSED WITHOUT THE WRITTEN APPROVAL OF BEL FUSE INC.

RoHS
2002/95/EC

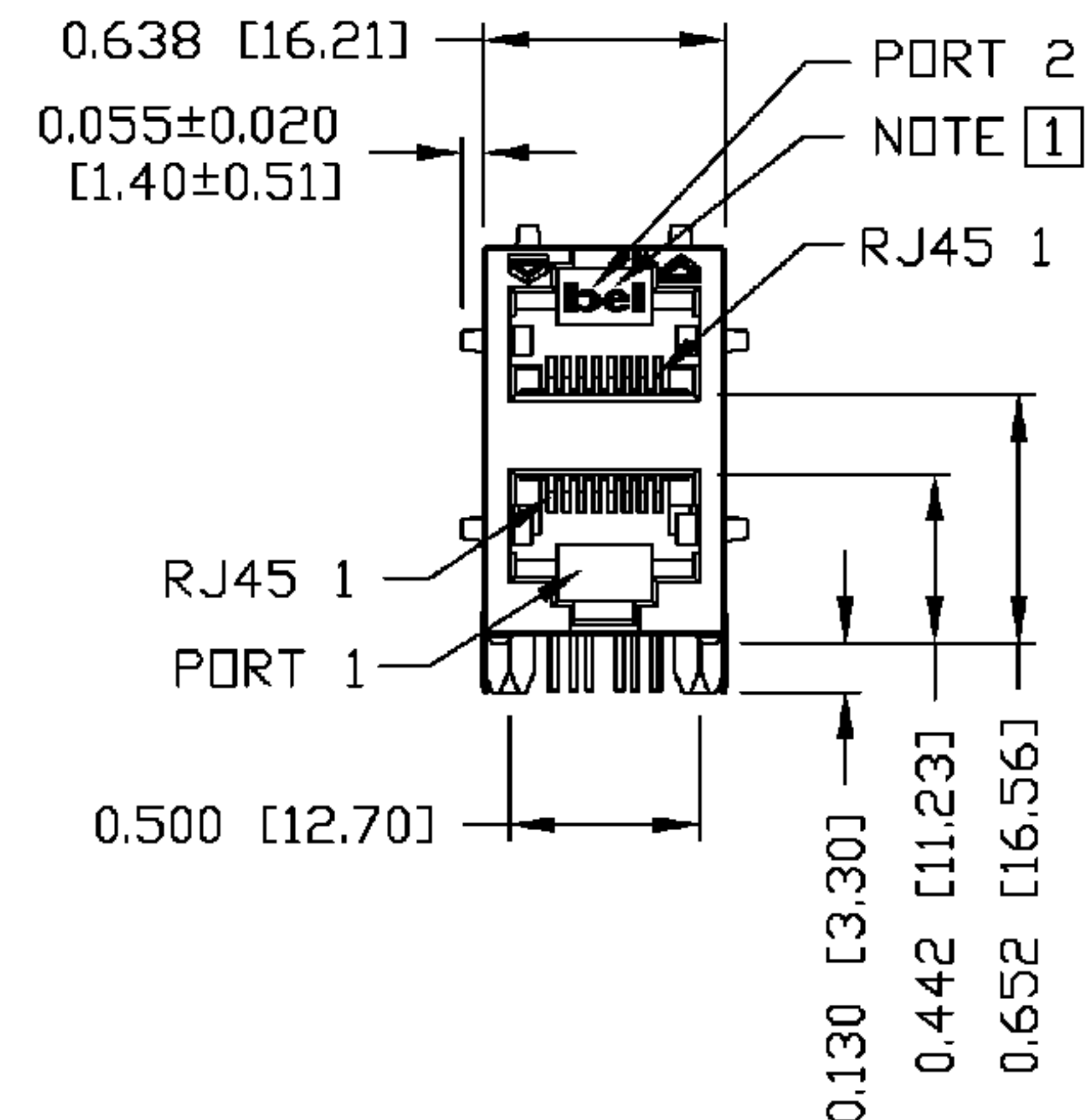
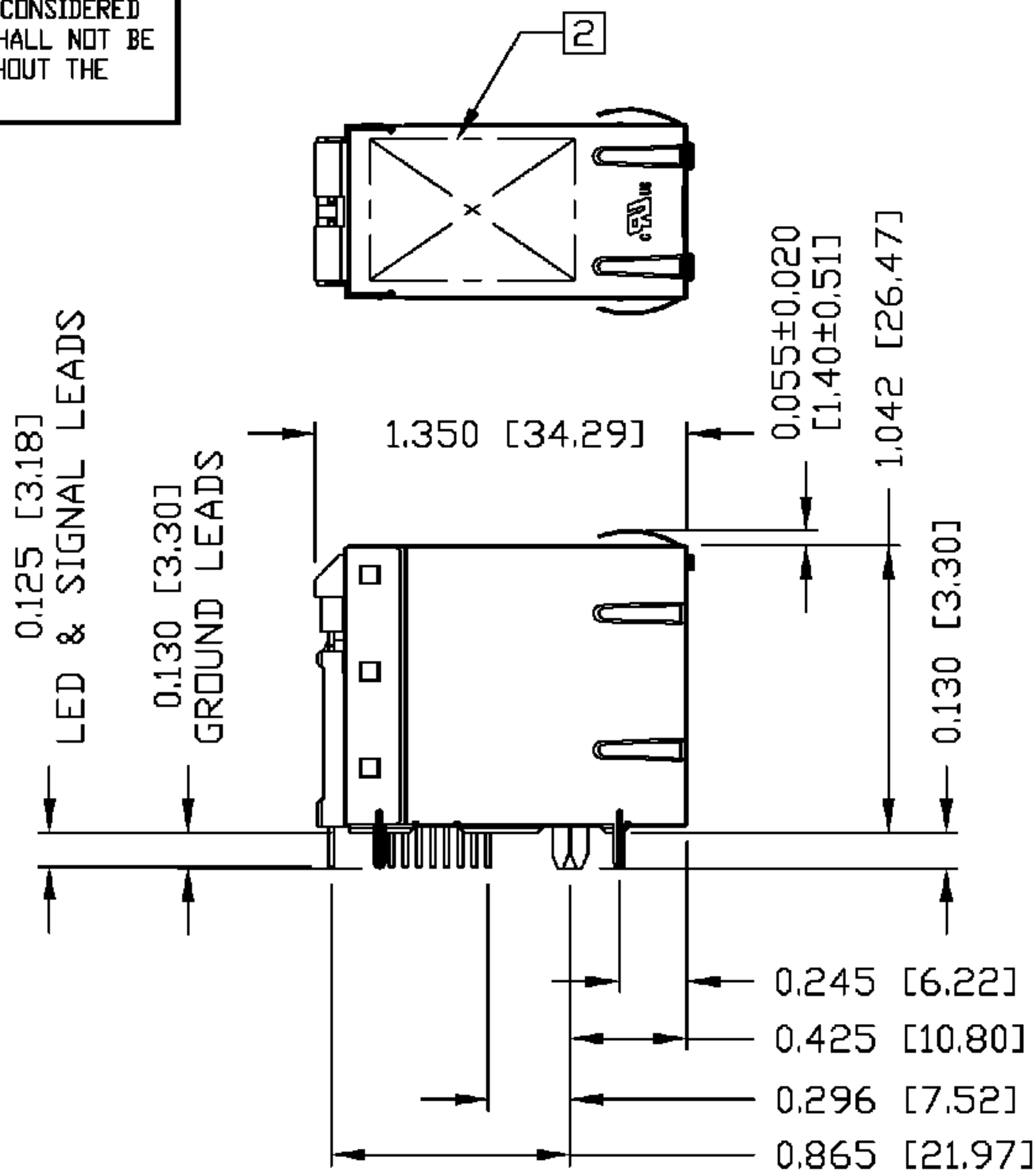

NOTES:

PLASTIC HOUSING: THERMOPLASTIC PBT
 FLAMMABILITY RATING UL 94V-0
 CONTACT PLATING: 50 MICRO-INCH HARD GOLD PLATING
 OUTPUT PINS: TIN-COATED COPPER WIRE, DIA 0.018 INCH.
 METAL SHIELD: NICKEL PLATED ON COPPER ALLOY.
 (ALL GROUND LEADS ARE SOLDER DIPPED)

1. JACK CAVITY CONFORMS TO FCC RULES AND REGULATIONS.

2. MARK PART WITH MFG LOGO, MFG NAME, PART NUMBER, AND DATE CODE.

UL UL RECOGNIZED - FILE #E196366 AND E169987.

RoHS COMPLIANT, PER EU DIRECTIVE 2002/95/EC

ORIGINATED BY QIN/BILL	DATE 06-12-06	TITLE 2X1 MagJack® (5 Cores, 10/100, with LED)	PART NO. / DRAWING NO. 08432B1T70-F	STANDARD DIM. TOL. IN INCH .X	[] METRIC DIM. AS REFERENCE UNIT : INCH [mm]	REV. : A	 COMPONENTS OF A CONNECTED PLANET
DRAWN BY TING	DATE 06-12-06	0843-2B1T-70-F	FILE NAME 08432B1T70-FA.DWG	.XX	SCALE : N/A	SIZE : A4	
				.XXX ±0.010		PAGE : 3	

THE INFORMATION CONTAINED HEREIN IS CONSIDERED "PROPRIETARY" TO BEL FUSE INC. AND SHALL NOT BE COPIED, REPRODUCED OR DISCLOSED WITHOUT THE WRITTEN APPROVAL OF BEL FUSE INC.



LED CONFIGURATION

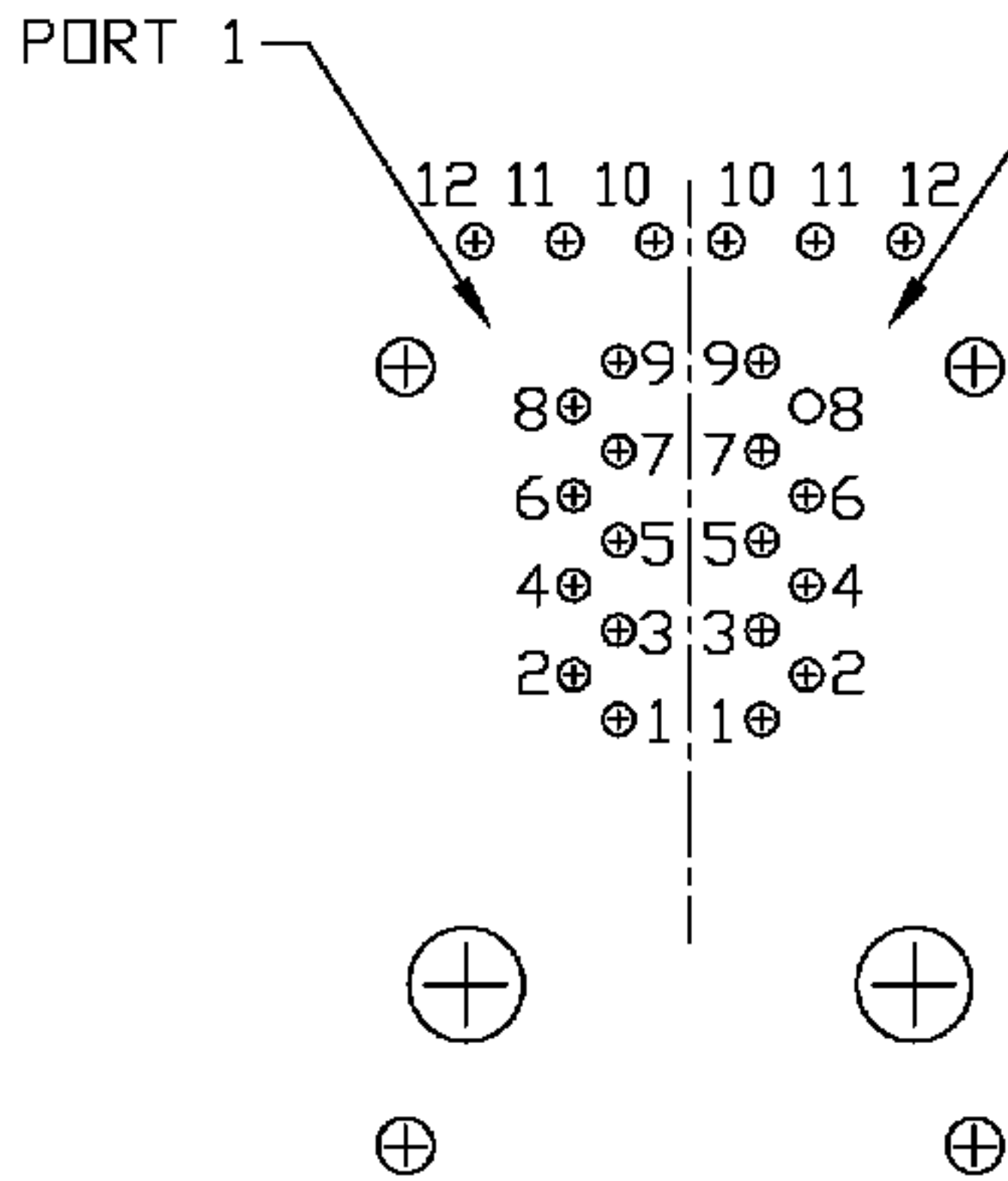
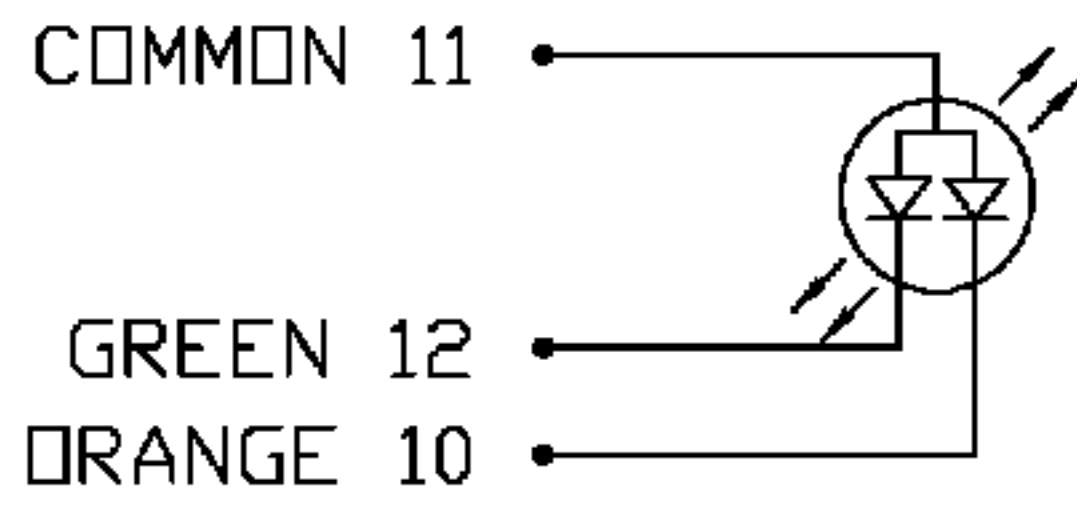

1	TD+
2	TD-
3	RD+
4	RD-
5	N/C
6	N/C
7	N/C
8	TCT
9	RCT
10	ORANGE LED CATHODE
11	COMMON ANODE
12	GREEN LED CATHODE

PIN-OUT INFORMATION
(COMPONENT SIDE VIEW)

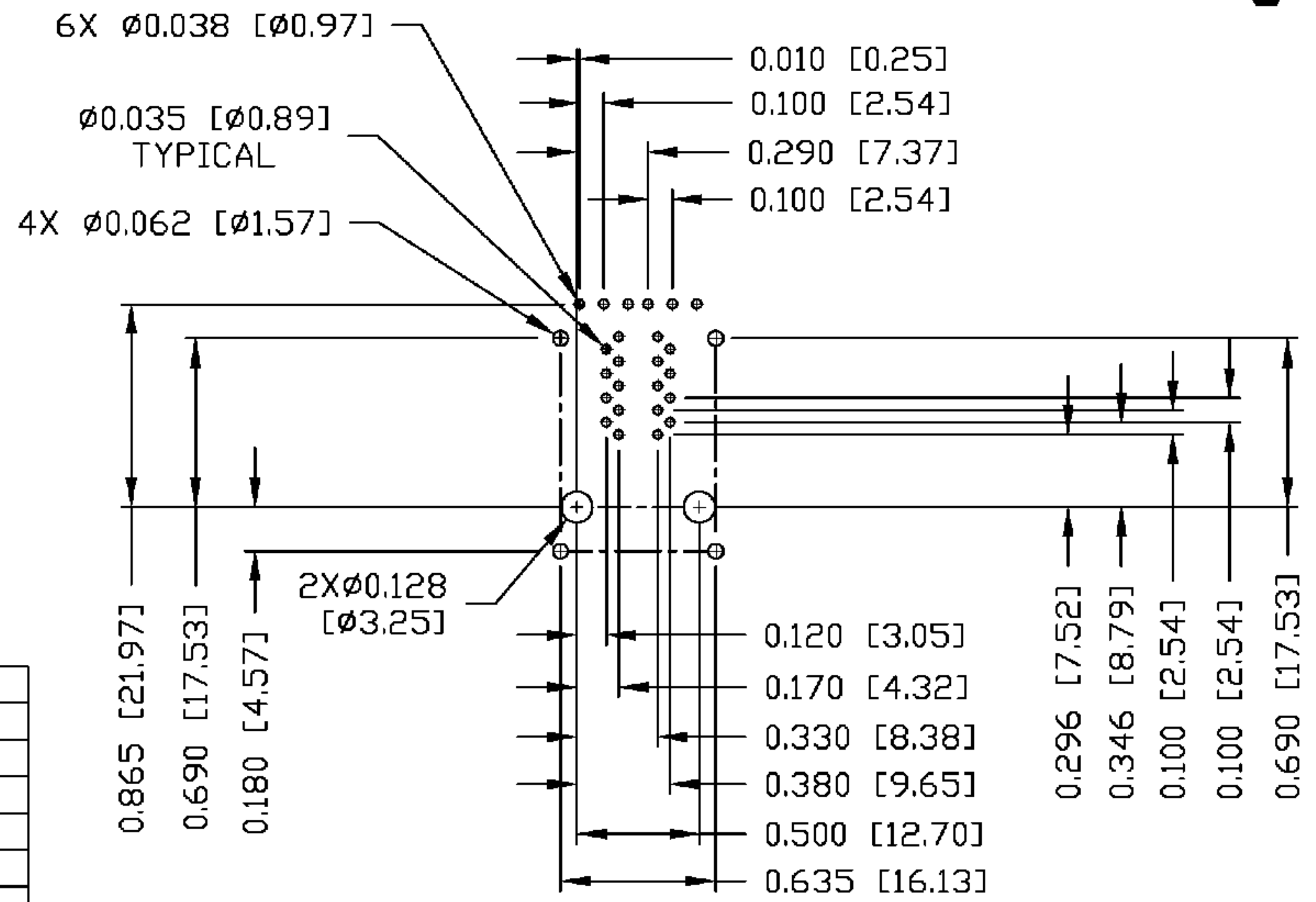

SUGGESTED FOOTPRINT
(COMPONENT SIDE VIEW)

ORIGINATED BY QIN/BILL	DATE 06-12-06	TITLE 2X1 MagJack® (5 Cores, 10/100, with LED)	PART NO. / DRAWING NO. 08432B1T70-F	STANDARD DIM. TOL. IN INCH		[] METRIC DIM. AS REFERENCE		bel COMPONENTS FOR A CONNECTED PLANET	
DRAWN BY TING	DATE 06-12-06			FILE NAME 08432B1T70-FA.DWG	.X		UNIT : INCH [mm]		REV. : A
					.XX		SCALE : N/A		SIZE : A4
			.XXX	±0.004		PAGE : 4			

THE INFORMATION CONTAINED HEREIN IS CONSIDERED "PROPRIETARY" TO BEL FUSE INC. AND SHALL NOT BE COPIED, REPRODUCED OR DISCLOSED WITHOUT THE WRITTEN APPROVAL OF BEL FUSE INC.



SUGGESTED PANEL OPENING

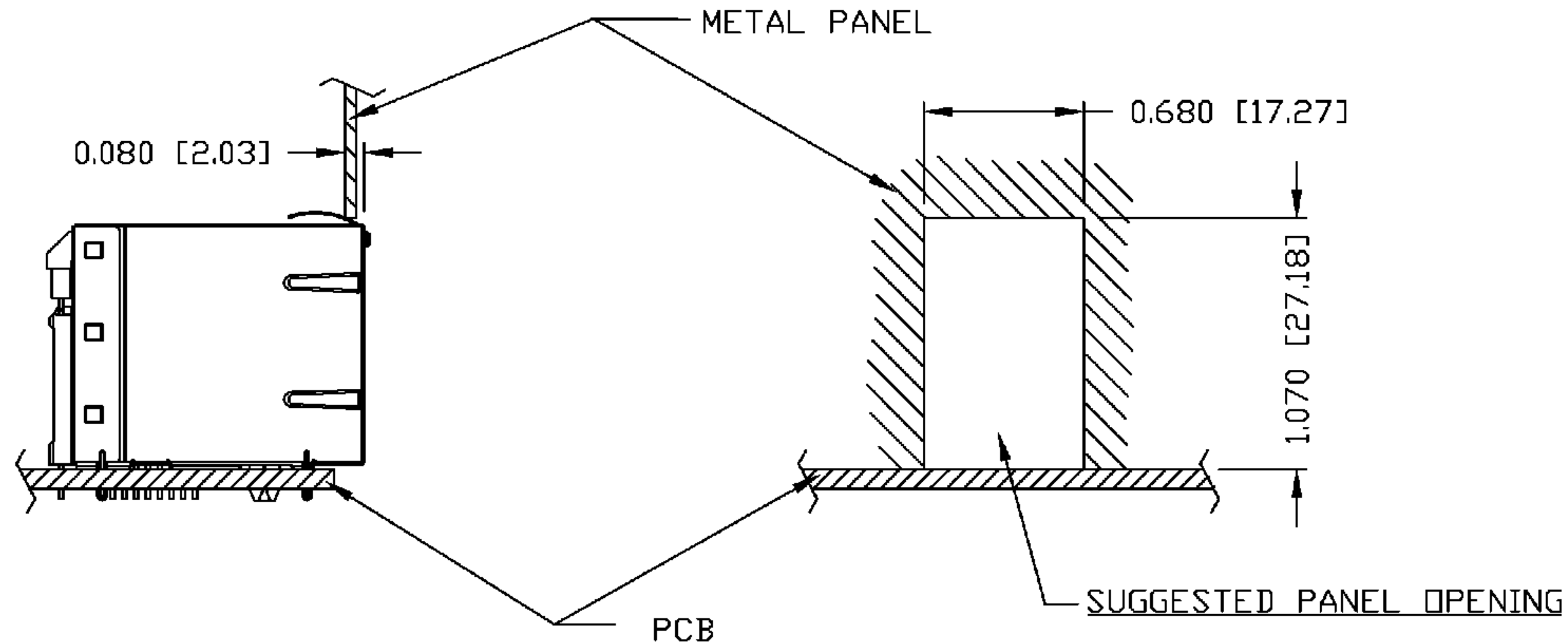

NOTE:

THE DISTANCE OF PANEL INSIDE SURFACE RELATIVE TO FRONT SURFACE OF PART IS ONLY A SUGGESTION. IN CASE THIS DISTANCE IS DIFFERENT, THE REQUIRED PANEL OPENING DIMENSIONS CHANGE ACCORDINGLY.

PACKING INFORMATION

PACKING TRAY: 0200-0148-36 (TOP)
0200-0148-34 (BOTTOM)

PACKING QUANTITY: 40 PCS FINISHED GOODS PER TRAY
6 TRAYS (240 PCS FINISHED GOODS) PER CARTON BOX.

NOTE: CARDBOARD ARE PLACED BETWEEN LAYERS OF PACKING TRAY INSIDE CARTON BOX.
(INCLUDE THE UPPERMOST AND LOWEREST TRAY)

ORIGINATED BY QIN/BILL	DATE 06-12-06	TITLE 2X1 MagJack® (5 Cores, 10/100, with LED)	PART NO. / DRAWING NO. 08432B1T70-F	STANDARD DIM.		[] METRIC DIM. AS REFERENCE		 COMPONENTS FOR A CONNECTED PLANET
					TOL. IN INCH	UNIT : INCH [mm]	REV. : A	
DRAWN BY TING	DATE 06-12-06	0843-2B1T-70-F	FILE NAME 08432B1T70-FA.DWG	.X	±0.004	SCALE : N/A	SIZE : A4	
				.XX			PAGE : 5	
				.XXX				

THE INFORMATION CONTAINED HEREIN IS CONSIDERED "PROPRIETARY" TO BEL FUSE INC. AND SHALL NOT BE COPIED, REPRODUCED OR DISCLOSED WITHOUT THE WRITTEN APPROVAL OF BEL FUSE INC.

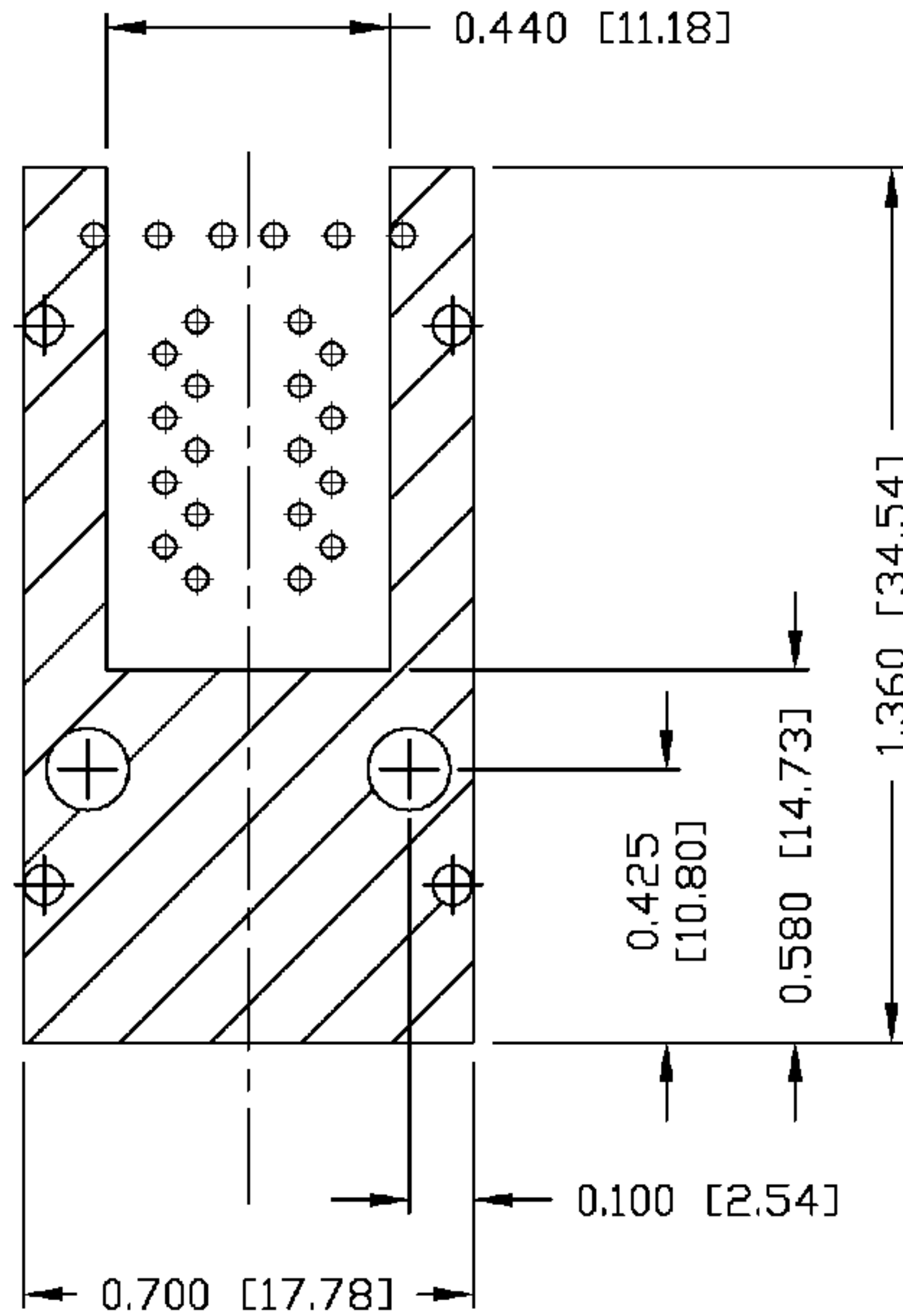

NOTES:

THE SHADED AREA ON THE CUSTOMER BOARD ARE RECOMMENDED TO BE CLEAR OFF ANY VIA HOLE OR COMPONENT PAD.

ORIGINATED BY QIN/BILL	DATE 06-12-06	TITLE 2X1 MagJack® (5 Cores, 10/100, with LED)	PART NO. / DRAWING NO. 08432B1T70-F	STANDARD DIM. TOL. IN INCH	[] METRIC DIM. AS REFERENCE		bel COMPONENTS FOR A CONNECTED PLANET
DRAWN BY TING	DATE 06-12-06		FILE NAME 08432B1T70-FA.DWG	.X	UNIT : INCH [mm]	REV. : A	
			.XX	SCALE : N/A	SIZE : A4		
			.XXX ±0.004	PAGE : 6			