

THE INFORMATION CONTAINED HEREIN IS CONSIDERED "PROPRIETARY" TO BEL FUSE INC. AND SHALL NOT BE COPIED, REPRODUCED OR DISCLOSED WITHOUT THE WRITTEN APPROVAL OF BEL FUSE INC.

LED1 POLARITY			LED2 POLARITY		
PIN 17	PIN 18	COLOR	PIN 19	PIN 20	COLOR
-	+	YELLOW	-	+	GREEN
			+	-	ORANGE

RoHS
2002/95/EC

RJ45

ELECTRICAL CHARACTERISTICS @ 25°C

URNS RATIO

TP1	1CT : 1CT ±2%
TP2	1CT : 1CT ±2%
TP3	1CT : 1CT ±2%
TP4	1CT : 1CT ±2%

OCL @ 100kHz, 20mVRMS AND 24mA DC BIAS FROM 0°C TO 70°C = 350uH MIN;
PAIRS (1-2), (3-6), (4-5) AND (7-8).

INS. LOSS

0.1MHz TO 1MHz	-0.8 dB MAX
1MHz TO 65MHz	-0.6 dB MAX
65MHz TO 100MHz	-1.2 dB MAX
100MHz TO 125MHz	-1.7 dB MAX

RET. LOSS (MIN)

0.5MHz-40MHz	-18 dB
40MHz-100MHz	-12+20LOG(f/80MHz) dB

CROSS TALK

100kHz - 1MHz	-60dB MIN
1MHz - 100MHz	-30dB MIN

CM TO CM REJ

100kHz - 100MHz	-30 dB MIN.
-----------------	-------------

CM TO DM REJ

100kHz - 100MHz	-25dB MIN.
-----------------	------------

HIPOT (Isolation Voltage):

2250 VDC

100% OF PRODUCTION TESTED TO COMPLY WITH
IEEE 802.3 ISOLATION REQUIREMENTS.

LED 1

VF (FORWARD VOLTAGE) IF=20mA YELLOW 2.1V TYP.
λD (DOMINANT WAVELENGTH) IF=20mA YELLOW 590nm TYP.

LED 2

VF (FORWARD VOLTAGE) IF=20mA GREEN 2.2V TYP.
ORANGE 2.0V TYP.
λD (DOMINANT WAVELENGTH) IF=20mA GREEN 565nm TYP.
ORANGE 610nm TYP.

DCR PINS CABLE SIDE (1-2), (3-6), (4-5) AND (7-8):

1.0 OHMS MAX.

BALANCED DC LINE CURRENT 700 mA MAX. @ 57 VDC CONTINUOUS
1.2A MAX. @ 57 VDC FOR 200 MILLISECONDS

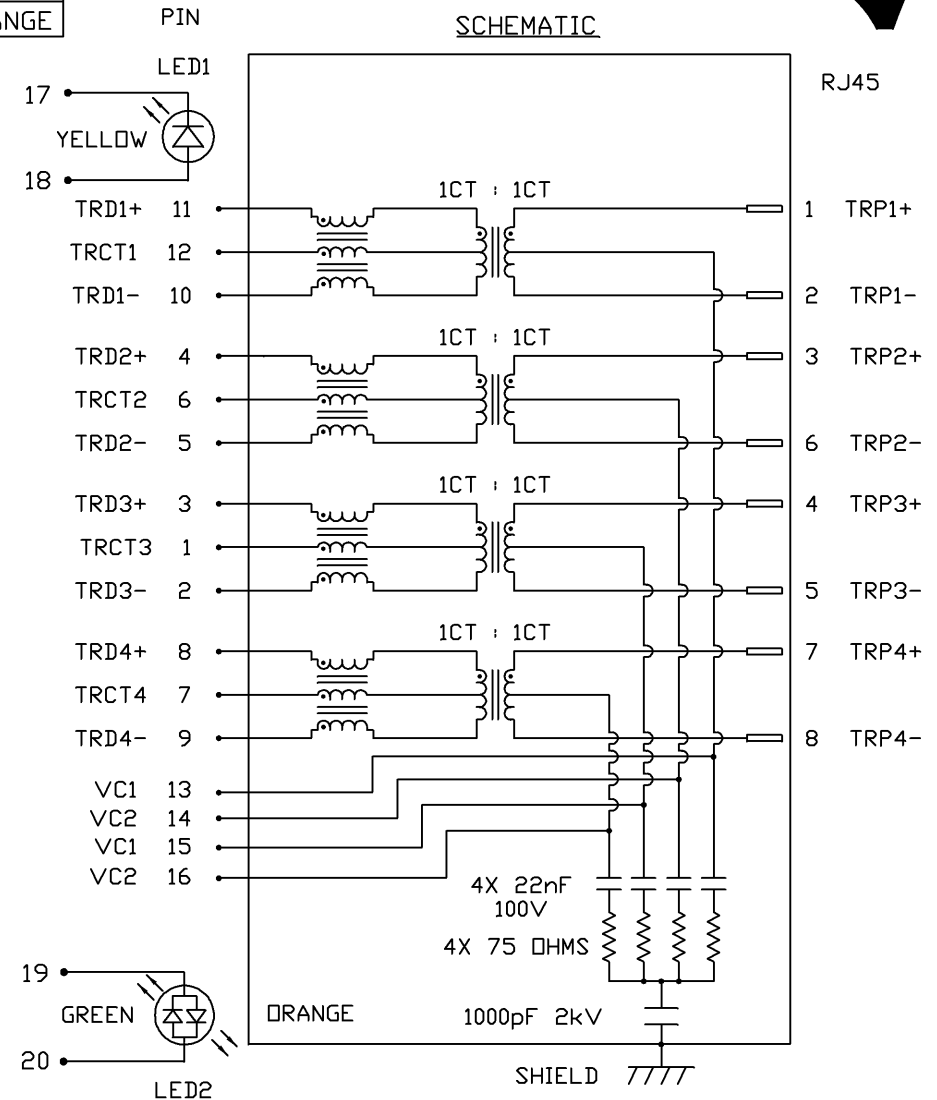

ORIGINATED BY	DATE	TITLE
CHOW WANCHUNG	01-08-09	
DRAWN BY	DATE	gigabit MagJack® with PoEp
LI YONGFENG	01-08-09	

PART NO. / DRAWING NO.	0838-1X1T-W7
FILE NAME	0838-1X1T-W7_B.DWG

STANDARD DIM. TOL. IN INCH	[] METRIC DIM. AS REFERENCE
.X	UNIT : INCH [mm]
.XX	REV. : B
.XXX	SCALE : N/A
	SIZE : A4
	PAGE : 2



THE INFORMATION CONTAINED HEREIN IS CONSIDERED "PROPRIETARY" TO BEL FUSE INC. AND SHALL NOT BE COPIED, REPRODUCED OR DISCLOSED WITHOUT THE WRITTEN APPROVAL OF BEL FUSE INC.

MECHANICAL SPECIFICATION

RoHS
2002/95/EC

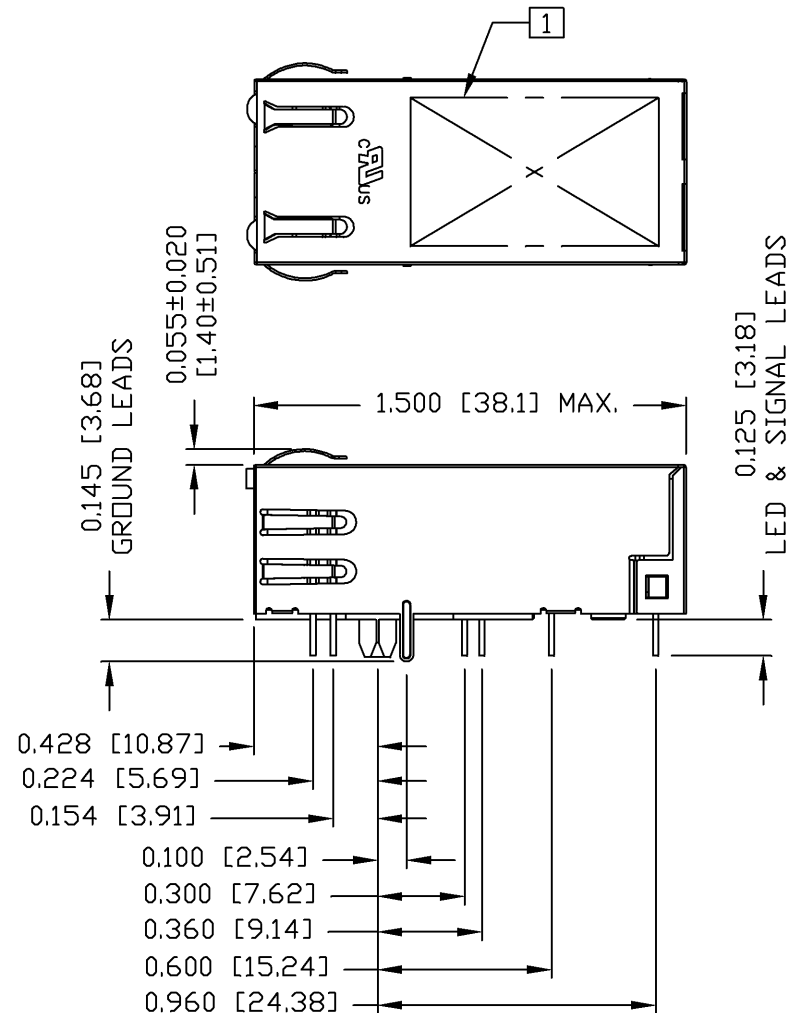
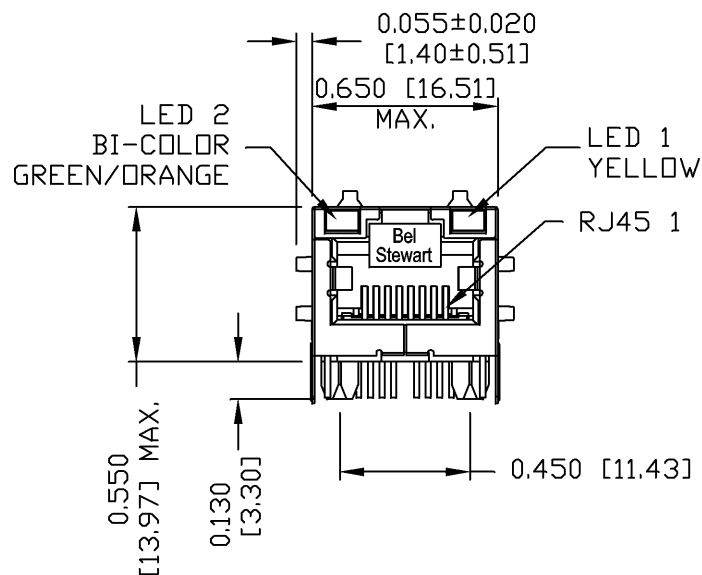

NOTES:

- PLASTIC HOUSING: THERMOPLASTIC PBT.
FLAMMABILITY RATING UL 94V-0.
- CONTACTS: 50 MICRO-INCH HARD GOLD PLATING.
- OUTPUT PINS: TIN-COATED COPPER WIRE, DIA 0.018 INCH.
- METAL SHIELD: NICKEL PLATED ON COPPER ALLOY.
- (ALL GROUND LEADS ARE SOLDER DIPPED)

1. MARK PART WITH MFG LOGO, MFG NAME, PART NUMBER, AND DATE CODE.

UL RECOGNIZED - FILE #E196366 AND E169987.
RoHS COMPLIANT, PER EU DIRECTIVE 2002/95/EC
JACK CAVITY CONFORMS TO FCC RULES AND REGULATIONS.

ORIGINATED BY	DATE	TITLE	PART NO. / DRAWING NO.	STANDARD DIM. TOL. IN INCH	[] METRIC DIM. AS REFERENCE	 COMPONENTS FOR A CONNECTED PLANET	
LIU QIN	01-08-09	gigabit MagJack® with PoEp	0838-1X1T-W7	.X	UNIT : INCH [mm]		REV. : B
DRAWN BY	DATE		FILE NAME	.XX	SCALE : N/A		SIZE : A4
XIAN JIAXIN	01-08-09		0838-1X1T-W7_B.DWG	.XXX	±0.010		PAGE : 3

THE INFORMATION CONTAINED HEREIN IS CONSIDERED "PROPRIETARY" TO BEL FUSE INC. AND SHALL NOT BE COPIED, REPRODUCED OR DISCLOSED WITHOUT THE WRITTEN APPROVAL OF BEL FUSE INC.



RECOMMENDED PCB FOOTPRINT

COMPONENT SIDE VIEW

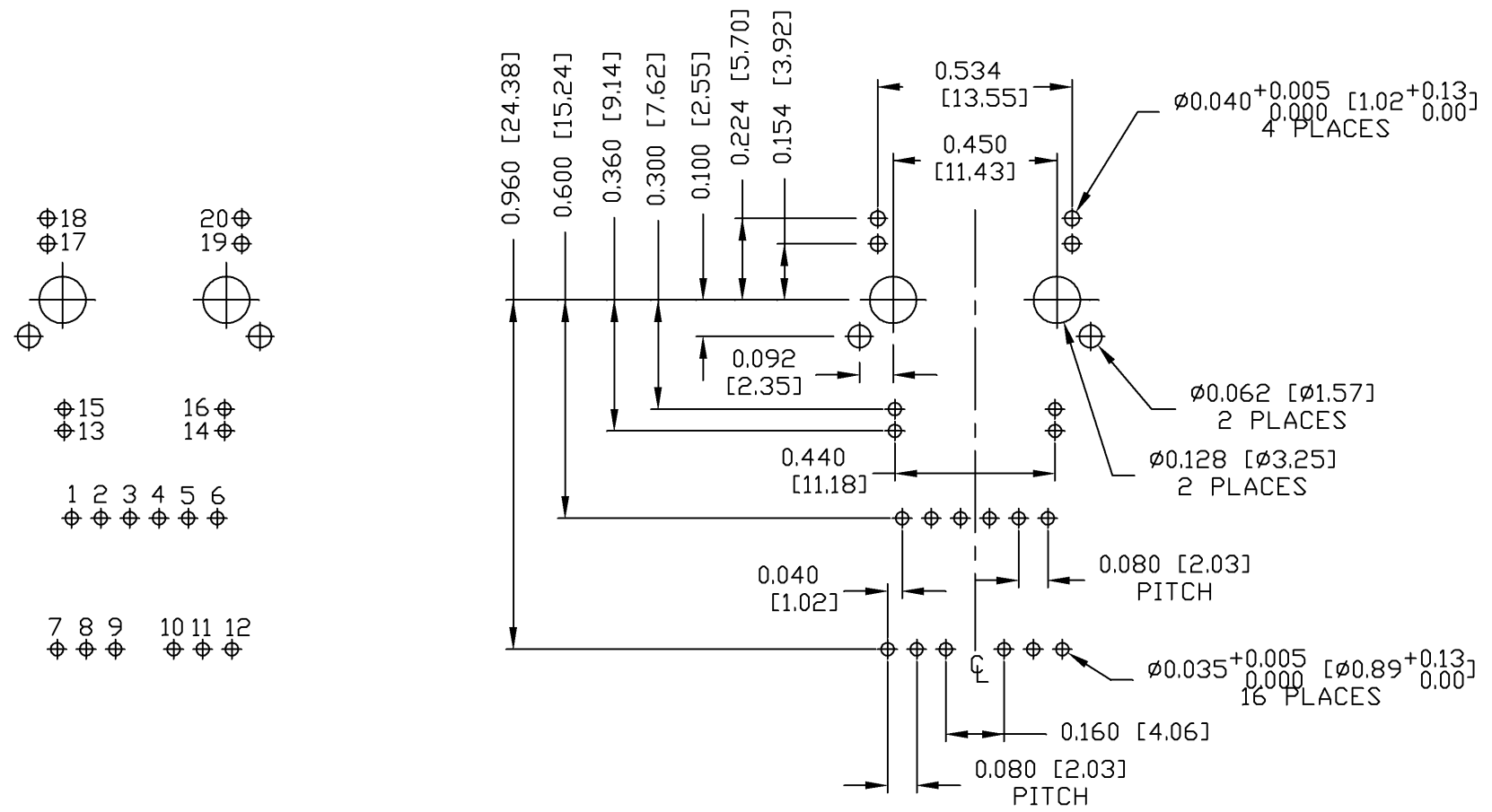

ORIGINATED BY LIU QIN	DATE 01-08-09	TITLE gigabit MagJack® with PoEp	PART NO. / DRAWING NO. 0838-1X1T-W7	STANDARD DIM. TOL. IN INCH	[] METRIC DIM. AS REFERENCE	
DRAWN BY XIAN JIAXIN	DATE 01-08-09		FILE NAME 0838-1X1T-W7_B.DWG	.X .XX .XXX ±0.004	UNIT : INCH [mm] SCALE : N/A	

THE INFORMATION CONTAINED HEREIN IS CONSIDERED "PROPRIETARY" TO BEL FUSE INC. AND SHALL NOT BE COPIED, REPRODUCED OR DISCLOSED WITHOUT THE WRITTEN APPROVAL OF BEL FUSE INC.

RoHS
2002/95/EC



SUGGESTED PANEL OPENING

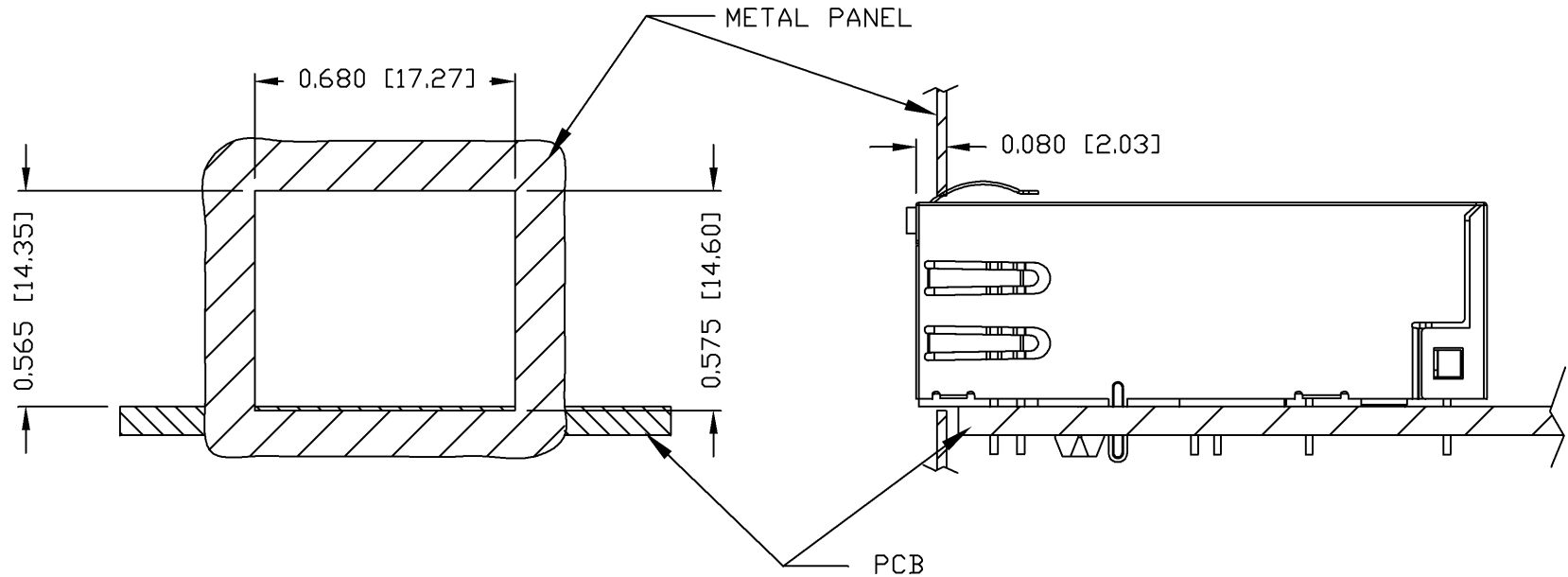

NOTE:

THE DISTANCE OF PANEL INSIDE SURFACE RELATIVE TO FRONT SURFACE OF PART IS ONLY A SUGGESTION. IN CASE THIS DISTANCE IS DIFFERENT, THE REQUIRED PANEL OPENING DIMENSIONS CHANGE ACCORDINGLY.

PACKING INFORMATION

PACKING TRAY : 0200-9999-R3 (TOP)
0200-9999-R4 (BOTTOM)

PACKING QUANTITY : 42 PCS FINISHED GOODS PER TRAY
10 TRAYS (420 PCS FINISHED GOODS) PER CARTON BOX

NOTE : CARDBOARDS ARE PLACED BETWEEN LAYERS OF PACKING TRAY INSIDE CARTON BOX
(INCLUDE THE UPPERMOST AND LOWERMOST TRAY)

ORIGINATED BY LIU QIN	DATE 01-08-09	TITLE gigabit MagJack® with PoEp	PART NO. / DRAWING NO. 0838-1X1T-W7	STANDARD DIM. TOL. IN INCH	[] METRIC DIM. AS REFERENCE		bel
	DRAWN BY XIAN JIAXIN		DATE 01-08-09	FILE NAME 0838-1X1T-W7_B.DWG	.X .XX .XXX	UNIT : INCH [mm] SCALE : N/A ±0.004	