

Adapters, In-Series

Quick Connect SMA, DC - 18 GHz

SPECIFICATIONS:

Model: 5030Q

RoHS
Compliant



Electrical:

Frequency Range _____ DC - 18.0 GHz
 VSWR:
 DC To 6GHz _____ 1.15:1 Maximum
 6 To 12.4GHz _____ 1.20:1 Maximum
 12.4 To 18GHz _____ 1.25:1 Maximum
 Impedance _____ 50 Ohms
 Operating Temp Range _____ -65°C to +85°C

Mechanical:

Connectors _____ White Bronze Plated Brass
Mates with MILSTD-348
 Conductors _____ Gold Plated Beryllium Copper
 Coupling Nuts _____ White Bronze Plated Brass

Model Number: 5030Q
 SMA Male to SMA Female

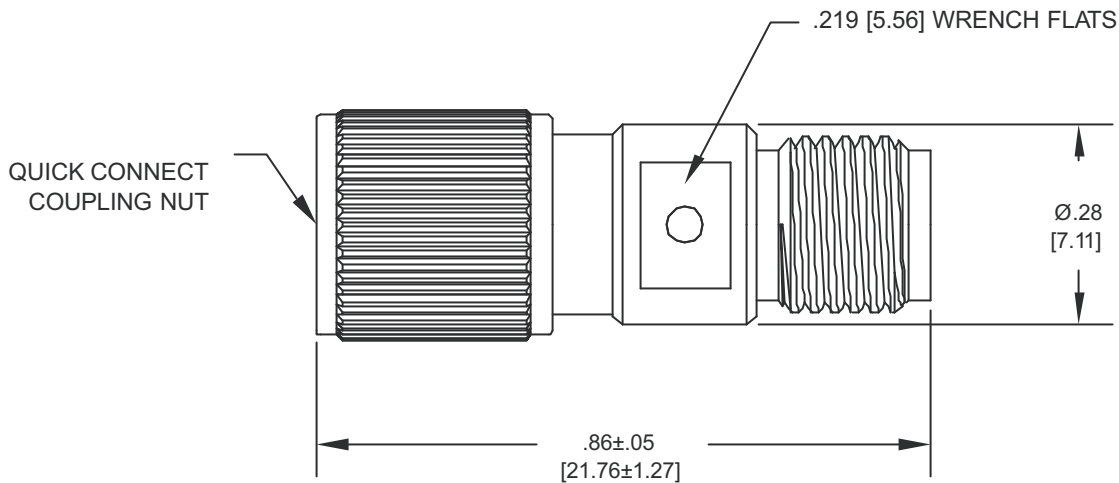

Note: Dimensions in Brackets are Expressed in Millimeters and are for Reference Only.

5030Q: REV -



Aeroflex / Inmet, Inc. • 300 Dino Drive, Ann Arbor, MI 48103 • U.S.A.
 888-244-6638 or 734-426-5553 • FAX: 734-426-5557
 www.aeroflex.com/inmet • inmet-sales@eroflex.com

5030Q Adapter

