

GT-0618-64

Standard Digital Attenuators

8 BIT

Applications

- Unsurpassed Attenuation Linearity over Frequency & Temperature
- 8 or 10 bit digital control
- Smooth transition between states
- Available in 32 or 64 dB Attenuation range
- Remotely programmable parallel or serial control interface



Specifications:

Parameter	Specification	Units
Frequency Range (min)	6.0 – 18.0	GHz
Attenuation Range	0 – 64	dB
Switching Speed	2.5	(usec)
Attenuation Flatness	±1.5 to 32 ±2.5 to 64	dB
Step Size (LSB)	0.250	dB
P1dB Compression Point (Max)	10	dBm
Insertion Loss (Max)	3.3	dB
VSWR (Max)	2.0:1	Ratio

Screening:

Internal Visual per MIL-STD-883, Method 2017
Temperature Cycle: -65 °C to +100 °C, 10 cycles

Hermetically-sealed switches are fine and gross leak checked per MIL-STD-883, Method 1014.

Optional High-Rel screening available upon request. Contact the factory to discuss your screening requirements.

Environmental Specifications:

Designed to meet:

MIL-E-5400, MIL-STD-202, MIL-E-16400

Operating Temp: -55°C to +125°C

Storage Temp: -65°C to +150°C

Humidity: MIL-STD-202F, M103, Cond B

Shock: MIL-STD-202F, M213, Cond B

Altitude: MIL-STD-202F, M105, Cond B

Vibration: MIL-STD-202F, M204, Cond B

Thermal Shock: MIL-STD-202F, M107, Cond A

Temperature Cycle: MIL-STD-202F, M105C, Cond D

Additional Electrical Specifications:

DC Supply: +5V ±0.5V @ +275mA

-5V ±0.5V @ -50mA

Control: 8 Bits command

1 Strobe line

Positive edge latched

TTL/HMOS

Attenuation Accuracy: +/-0.15 dB or +/-1.5%

whichever is greater

Attenuation Stability
over Temperature: +/-0.025 dB/°C

Mechanical Specifications:

Case Style: GT Outline

Finish: Gold Plate per MIL-G-45204

Bias & Control Pins: ø0.02" x 0.15" long

Connectors: SMA Female per MIL-C-39012

Weight: 90g max

Mounting: ø0.10" through holes
(4) places



Revision Date: 2/23/2011

40 Industrial Way East, Eatontown, NJ 07724 [USA]

Phone: (732) 460-0212, Fax: (732) 460-0214

www.aeroflex.com/acc, email: acc-sales@aeroflex.com

AEROFLEX

CONTROL COMPONENTS
Outline Drawing:

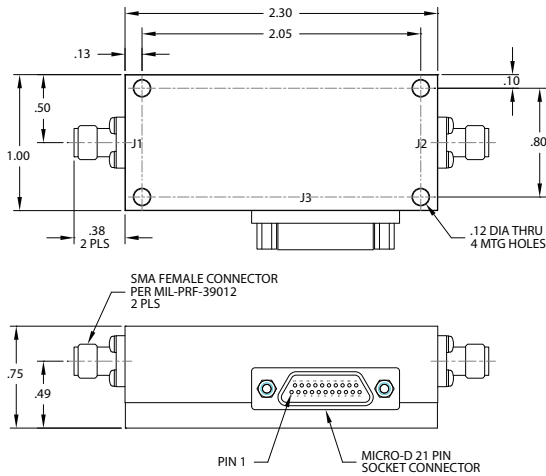

PIN	FUNCTION
1	RETURN
2	STROBE
3	b0
4	b1
5	b2
6	b3
7	b4
8	b5
9	b6
10	b7
11	N/C (b8*)
12	N/C (b9*)
13	N/C
14	N/C
15	+V
16	RETURN
17	-V
18	N/C
19	RETURN
20	N/C
21	N/C

*Used on 10 bit option

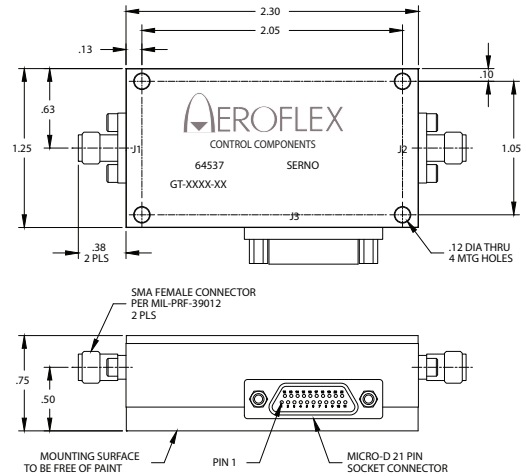

OUTLINE CASE STYLE GT

Notes:

1. Mean Attenuation = average attenuation over the frequency range at constant command.
2. Measurements at 0 dBm input power unless otherwise
3. Attenuation range must be specified by adding a "32 or 64" to the end of the part number (eg. GT061832)
4. Standard Control Interface is 8 bit. Control interface is also available in 10 bit interface. Add suffix (10) after attenuation range suffix. Other custom options available upon request.

Part Number Ordering Information: Custom Options – Contact the Factory

- GT : Series
- - 0206 : Frequency Range
- - 64 : Attenuation Range (32) or (64)
- - 10 : 10 bits
- - F : Free Running
- - H : Hemetic Seal
- Gray epoxy paint per MIL-C-22750
- Video transient suppression
- GPO connectors
- ECL logic input
- Phase and amplitude tracking
- Other frequency ranges available from 1MHz to 26GHz
- Reversed logic
- Available without SMA connectors for drop-in applications
- High rel screening

Aeroflex Control Components
Aeroflex Microelectronic Solutions
40 Industrial Way East
Eatontown, NJ 07724 [USA]
Fax: (732) 460-0214

Sales
Phone: (732) 460-0212
ACC-sales@aeroflex.com

www.aeroflex.com/Microwave www.aeroflex.com/ACC

Aeroflex Control Components reserves the right to make changes to any products and services herein at any time without notice. Consult Aeroflex or an authorized sales representative to verify that the information in this data sheet is current before using this product. Aeroflex does not assume any responsibility or liability arising out of the application or use of any product or service described herein, except as expressly agreed to in writing by Aeroflex; nor does the purchase, lease, or use of a product or service from Aeroflex convey a license under any patent rights, copyrights, trademark rights, or any other of the intellectual rights of Aeroflex or of third parties.

Copyright 2011 Aeroflex Control Components. All rights reserved.

ISO 9001:2008 certified



Our passion for performance is defined by three attributes represented by these three icons: solution-minded, performance-driven and customer-focused.