

Standard Products

ACT4458/4464 Single Supply Dual Transceivers for MIL-STD-1553/1760

www.aeroflex.com/Avionics

October 20, 2004



FEATURES

- ❑ Small size, light weight and low standby power dual transceiver
- ❑ Single +5V power supply
- ❑ Monolithic construction
- ❑ Input and output TTL compatible design
- ❑ Processed and screened to MIL-STD-883 specs
- ❑ MIL-PRF-38534 compliant devices available
- ❑ Aeroflex-Plainview is a Class H & K MIL-PRF-38534 manufacturer
- ❑ DESC SMD# 5962-92061

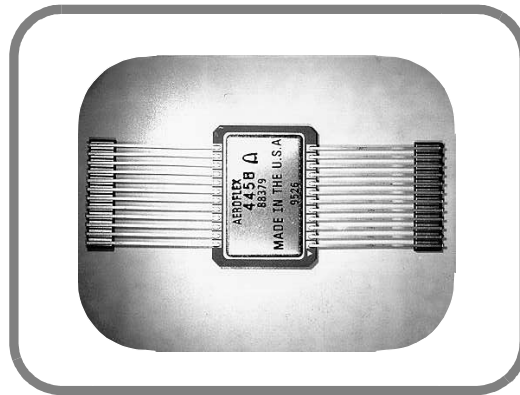

ACT4458

Case Style

Actual Size

GENERAL DESCRIPTION

The Aeroflex-Plainview ACT4458/4464 series are next generation monolithic transceiver designs which provides full compliance with MIL-STD-1553A/B and 1760 requirements in the smallest packages with low power consumption and single power supply operation. The series performs the front-end analog function of inputting and outputting data through a transformer to the MIL-STD-1553 data bus.

Design of these transceivers reflects particular attention to active filter performance. This results in low bit and word error rate with superior waveform purity and minimal zero crossover distortion. Efficient transmitter electrical and thermal design provides low internal power dissipation and heat rise at high as well as low duty cycles.

Each channel of the dual transceiver is completely separate from the other and fully independent. This includes power leads as well as signal lines. Hence, each channel may be connected to a different data bus with no interaction.

TRANSMITTER

The Transmitter section accepts bi-phase TTL data at the input and when coupled to the data bus with a 1:2.5 ratio transformer the data bus signal is typically 7.5 volts P-P at A-A' (See Figure 5). When both DATA and $\overline{\text{DATA}}$ inputs are held low or high, the transmitter output becomes a high impedance and is "removed" from the line. In addition, an overriding "INHIBIT" input provides for the removal of the transmitter output from the line. A logic "1" applied to the "INHIBIT" takes priority over the condition of the data inputs and disables the transmitter (See Transmitter Logic Waveform, Figure 1). The Transmitter may be safely operated for an indefinite period with the bus (point A-A') short circuited at 100% duty cycle.

RECEIVER

The Receiver section accepts bi-phase differential data at the input and produces two TTL signals at the output. The outputs are DATA and $\overline{\text{DATA}}$, and represent positive and negative excursions of the input beyond a pre-determined threshold (See Receiver Logic Waveform, Figure 2).

The pre-set internal thresholds will detect data bus signals exceeding 1.20 Volts P-P and reject signals less than 0.6 volts P-P when used with a transformer (See Figure 5 for transformer data and typical connection).

A low level at the Strobe input inhibits the DATA and $\overline{\text{DATA}}$ outputs. If unused, a 2K pull-up to +5 Volts is recommended.

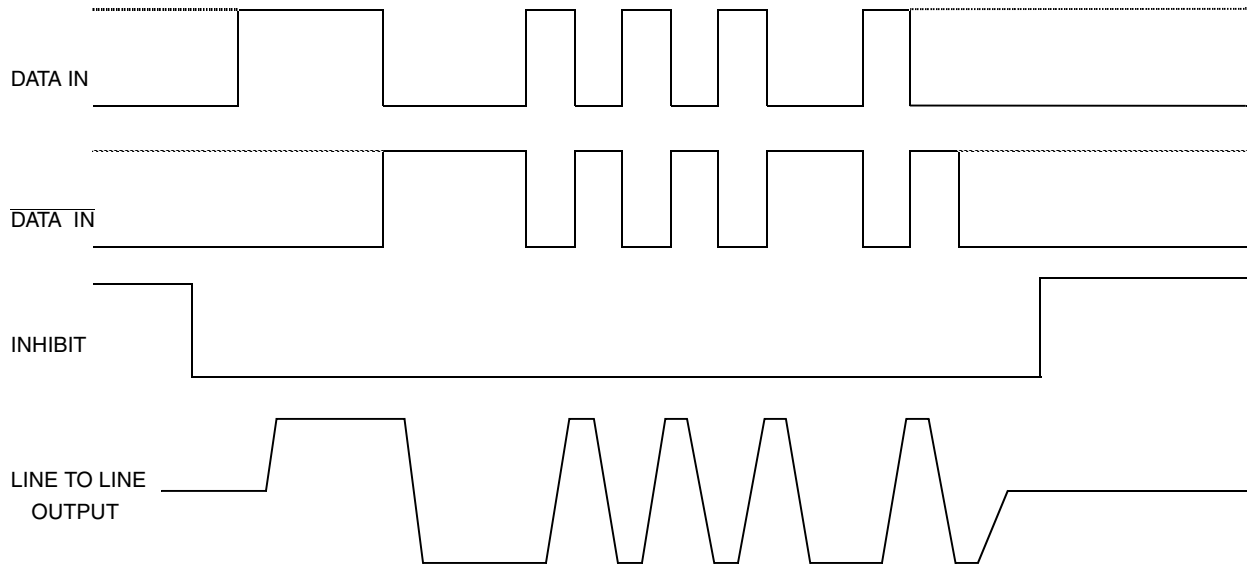
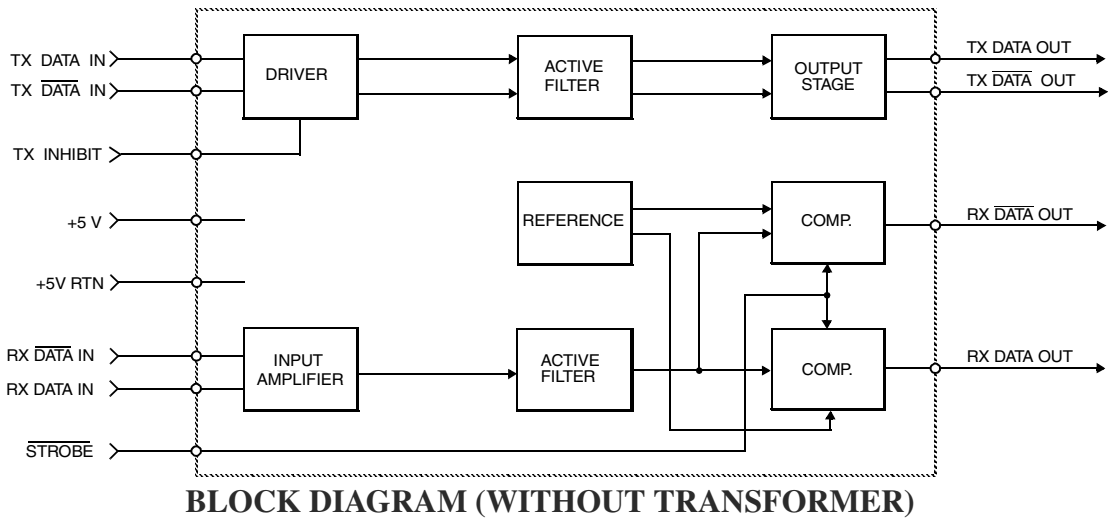

Note: DATA and $\overline{\text{DATA}}$ inputs must be complementary waveforms or 50% duty cycle average, with no delays between them, and must be in the same state during off times (both high or low).

FIGURE 1 – TRANSMITTER LOGIC WAVEFORMS IDEALIZED *

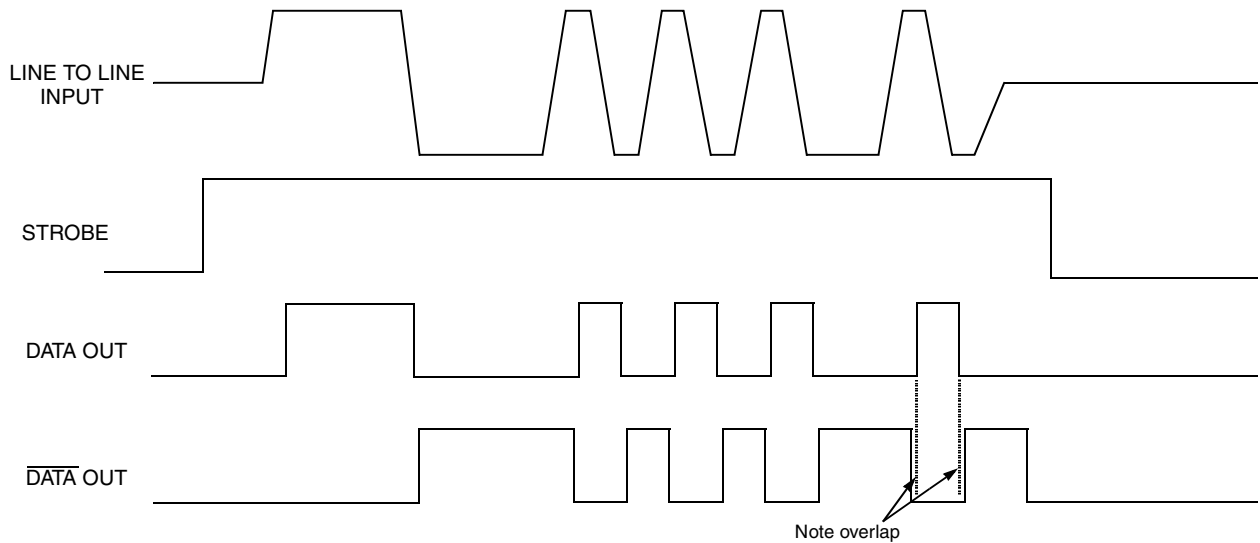

FIGURE 2 – RECEIVER LOGIC WAVEFORMS IDEALIZED *

* See Figure 7 for Actual Waveforms

ABSOLUTE MAXIMUM RATINGS

Operating case temperature	-55°C to +125°C
Storage case temperature	-65°C to +150°C
Power supply voltage	-0.3V _{DC} to +7.0V _{DC}
Logic input voltage	-0.3V _{DC} to +5.5V _{DC}
Receiver differential input	±10 V
Receiver input voltage (common mode)	±5V
Driver peak output current	800 mA
Total package power dissipation over the full operating case temperature range	2.0 Watts (Note: Normal operation conditions require one transmitter on and the other off at any given time)
Maximum junction to case temperature	10°C
Thermal resistance – Junction to case	5°C/W

ELECTRICAL CHARACTERISTICS – DRIVER SECTION

INPUT CHARACTERISTICS, TX DATA IN OR TX $\overline{\text{DATA IN}}$ (Notes 2 & 3 Apply)

Parameter	Condition	Symbol	Min	Typ	Max	Unit
"0" Input Current	V _{IN} = 0.4V	I _{ILD}	-	-0.2	-0.4	mA
"1" Input Current	V _{IN} = 2.7V	I _{IHD}	-	1	40	μA
"0" Input Voltage		V _{ILD}	-	-	0.7	V
"1" Input Voltage		V _{IHD}	2.0	-	-	V

INHIBIT CHARACTERISTICS

"0" Input Current	V _{IN} = 0.4V	I _{ILI}	-	-0.2	-0.4	mA
"1" Input Current	V _{IN} = 2.7V	I _{IHI}	-	1.0	40	μA
"0" Input Voltage		V _{ILI}	-	-	0.7	V
"1" Input Voltage		V _{IHI}	2	-	-	V
Delay from TX inhibit, (0→1) to inhibited output		t _{DXOFF}	-	250	350	nS
Delay from TX inhibit, (1→0) to active output		t _{DXON}	-	150	250	nS
Differential Output Noise, inhibit mode		V _{NOI}	-	2	10	mVp-p
Differential Output Impedance (inhibited)	Note 1	Z _{OI}	2K	-	-	Ω

OUTPUT CHARACTERISTICS

Differential output level	R _L = 35 Ω	V _O	6	7.5	9	V _{p-p}
Rise and fall times (10% to 90% of p-p output)		t _r	100	200	300	nS
Output offset at point A-A' on Figure 5, 2.5 μS after midpoint crossing of the parity bit of the last word of a 600μS message	R _L = 35 Ω	V _{OS}	-	-	±90	mVpeak
Delay from 50% point of TX DATA or $\overline{\text{TX DATA}}$ input to zero crossing of differential signal		t _{DTX}	-	120	250	nS

ELECTRICAL CHARACTERISTICS – RECEIVER SECTION

Parameter	Condition	Symbol	Min	Typ	Max	Unit
Differential Voltage Range (See Figure 5, point P-P')	TXFMR 2.5:1	V_{IDR}	-	14	20	V _{p-p}
Common Mode Rejection Ratio (Note 3)		CMRR	45	-	-	dB

STROBE CHARACTERISTICS (LOGIC "0" INHIBITS OUTPUT)

"0" Input Current	$V_S = 0.4V$	I_{IL}	-	-0.2	-0.4	mA
"1" Input Current	$V_S = 2.7V$	I_{IH}	-	1	+40	μA
"0" Input Voltage		V_{IL}	-	-	0.7	V
"1" Input Voltage		V_{IH}	2.0	-	-	V
Strobe Delay (Turn-on or Turn-off)		t_{SD}	-	50	100	nS

THRESHOLD CHARACTERISTICS (SINEWAVE INPUT)

Internal Threshold Voltage (Referred to the bus)	100KHz-1MHz	V_{TH}	0.60	0.82	1.10	V _{p-p}
--	-------------	----------	------	------	------	------------------

OUTPUT CHARACTERISTICS, RX DATA AND $\overline{RX DATA}$

"1" State	$I_{OH} = -0.4mA$	V_{OH}	2.5	3.7	-	V
"0" State	$I_{OL} = -4mA$	V_{OL}	-	0.35	0.5	V
Delay, (average) from differential input zero crossings to RX DATA and $\overline{RX DATA}$ output	50% points	t_{DRX}	-	340	400	nS

POWER DATA

POWER SUPPLY CURRENTS – PER CHANNEL

Transmitter Standby	(Note 4)	I_{CC}	-	18	30	mA
25% Duty Cycle			-	150	175	
50% Duty Cycle			-	300	350	
100% Duty Cycle			-	600	700	

POWER SUPPLY VOLTAGE

Operating Power Supply Voltage Range		V_{CC}	+4.75	+5.00	+5.50	V
--------------------------------------	--	----------	-------	-------	-------	---

NOTES:

- Power on or off, measured from 75KHz to 1MHz at point A-A' and transformer self impedance of 3K Ω minimum.
- $V_{CC} = 5$ Volts ± 0.1 V, bypassed by 2.2 μF (Tantalum recommended) Capacitor minimum. All measurements & specifications apply over the temperature range of -55°C to +125°C (case temperature) unless otherwise specified.
- When measured at point A-A' with ± 10 Volt peak, line to ground, DC to 2MHz.
- Typical power is measured with V_{bus} at point A-A' = 7.5 V_{p-p}.

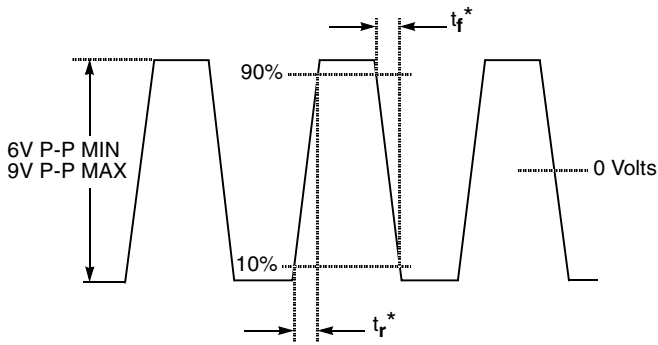

* Rise and fall times measured at point A-A' in Figure 5

FIGURE 3 – TRANSMITTER (TX) OUTPUT WAVEFORM

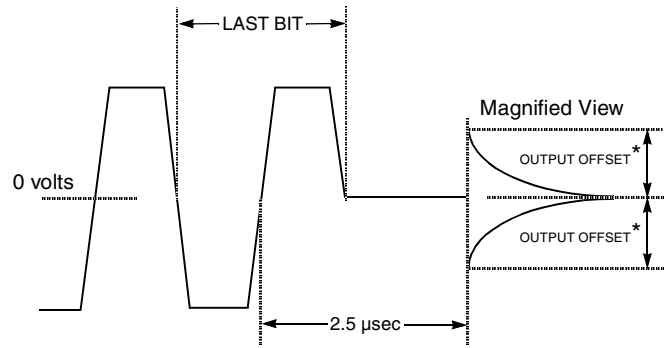

*Offset measured at point A-A' in Figure 5

FIGURE 4 – TRANSMITTER (TX) OUTPUT OFFSET

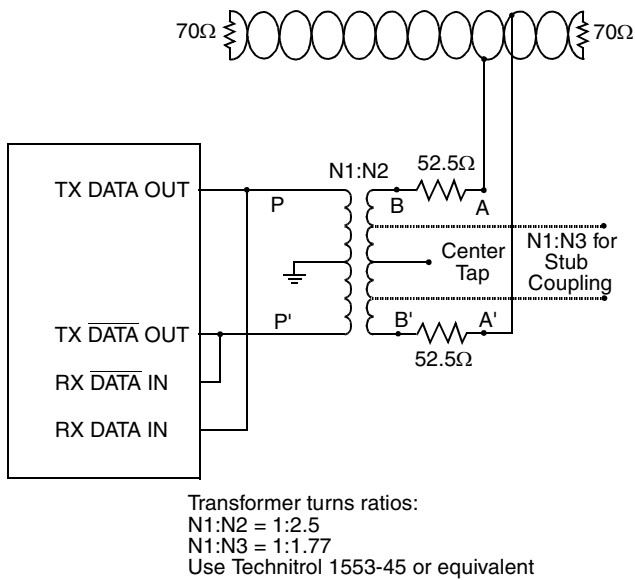
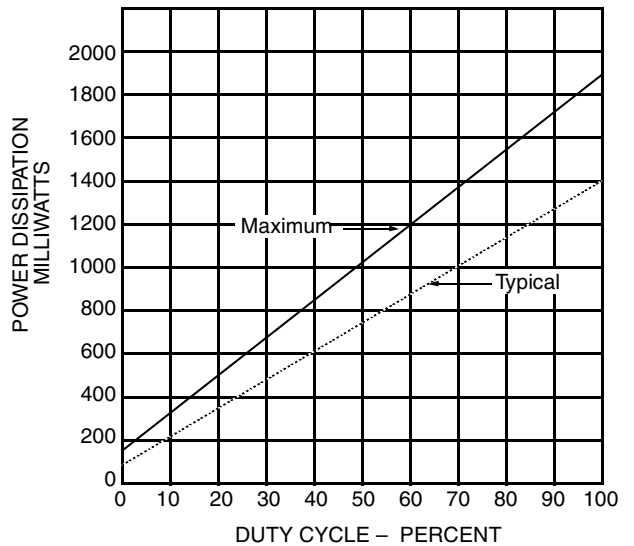

FIGURE 5 – TYPICAL TRANSFORMER DIRECT CONNECTION



Note: $V_{cc}=5$ Volts, Transformer ratio 1:2.5, V_{bus} (pt A-A') at 7.5 Volts P-P

FIGURE 6 – POWER DISSIPATION VS. DUTY CYCLE
 (Total, hybrid with one channel transmitting and the other not powered)

START OF WORD – 33 WORD TRANSMISSION

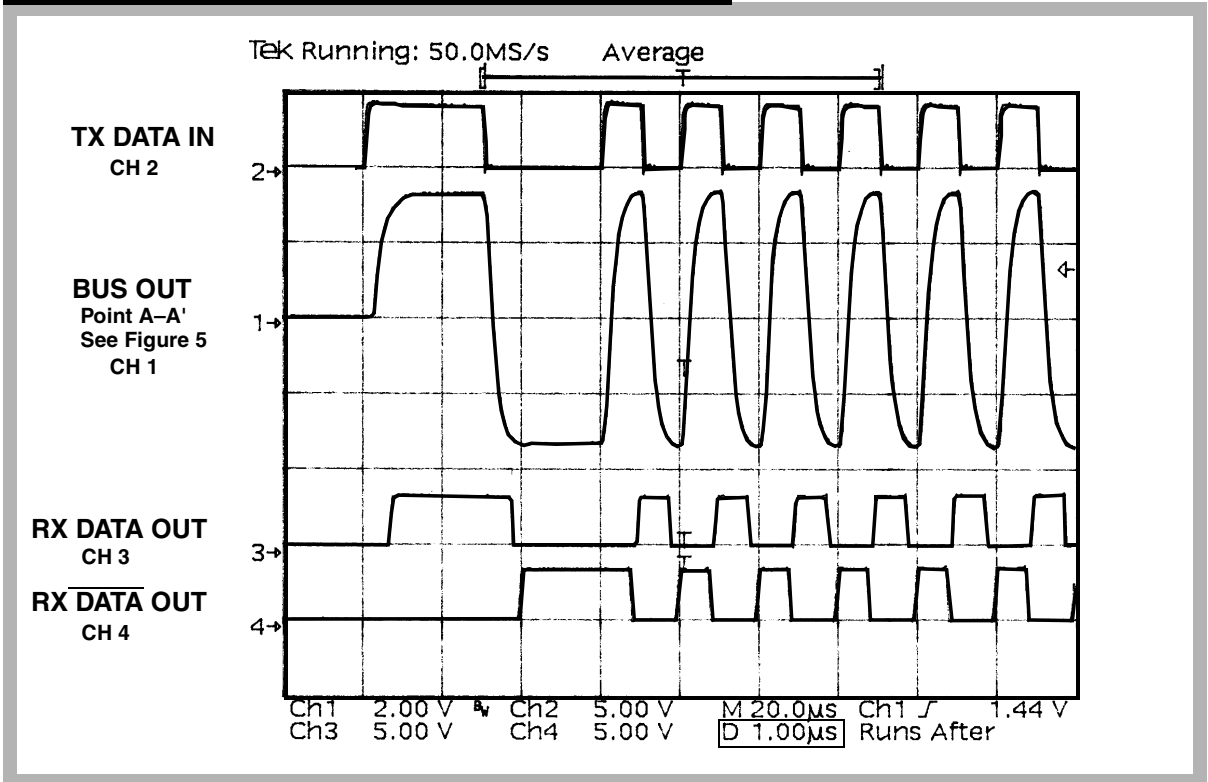

END OF WORD – 33 WORD TRANSMISSION

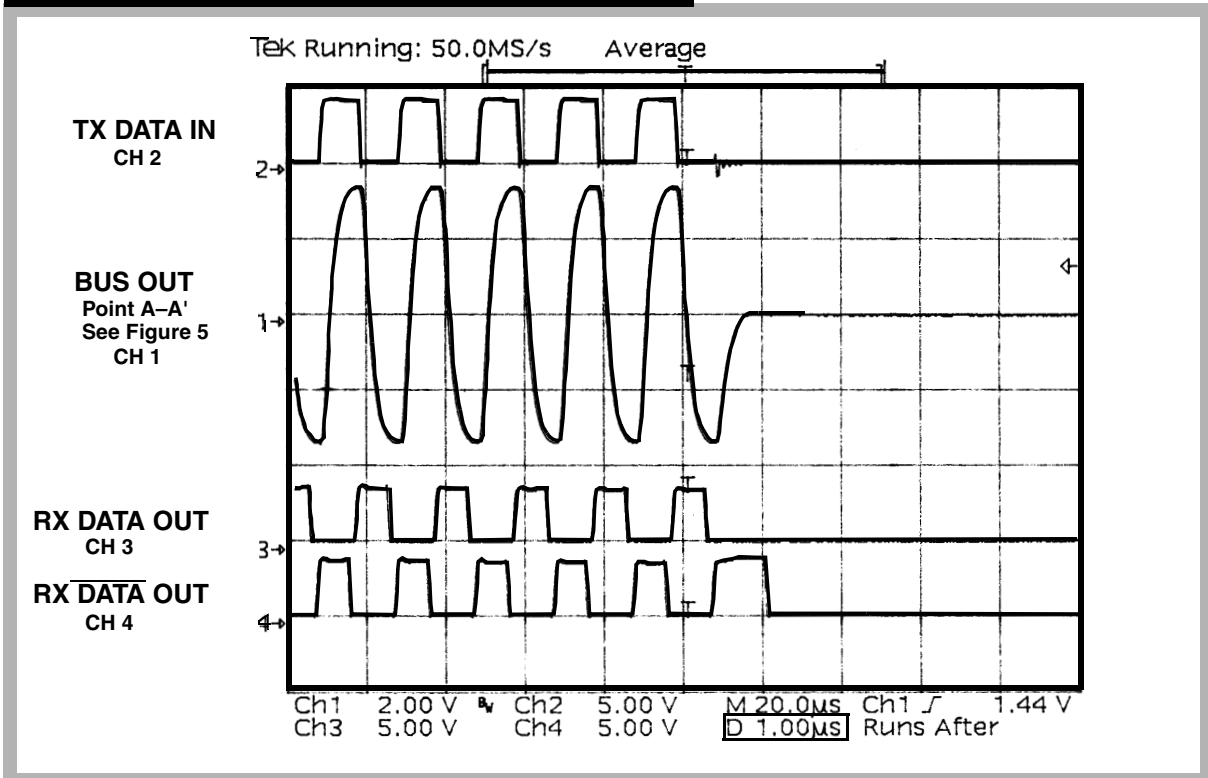

* Oscilloscope used is a TEK TDS540 with Probe 6139A.

FIGURE 7 ACTUAL HYBRID WAVEFORMS * – 25°C TYPICAL

PIN NUMBERS & FUNCTIONS

Pin #	Function	Channel
1	TX DATA OUT/RX DATA IN	A
2	TX $\overline{\text{DATA}}$ OUT/RX $\overline{\text{DATA}}$ IN	A
3	GROUND 1	A
4	RX DATA OUT	A
5	STROBE	A
6	RX $\overline{\text{DATA}}$ OUT	A
7	TX DATA OUT/RX DATA IN	B
8	TX $\overline{\text{DATA}}$ OUT/RX $\overline{\text{DATA}}$ IN	B
9	GROUND 1	B
10	RX DATA OUT	B
11	STROBE	B
12	RX $\overline{\text{DATA}}$ OUT	B
13	GROUND 2	B
14	+5V	B
15	GROUND 3	B
16	INHIBIT	B
17	TX DATA IN	B
18	TX $\overline{\text{DATA}}$ IN	B
19	GROUND 2	A
20	+5V	A
21	GROUND 3	A
22	INHIBIT	A
23	TX DATA IN	A
24	TX $\overline{\text{DATA}}$ IN	A

CONFIGURATIONS AND ORDERING INFORMATION

Model No.	DESC No.	Receiver Data level	Configuration
ACT 4458	5962-9206107	Normally Low	Dual
ACT 4464	5962-9206108	Normally High	

FLAT PACKAGE CONFIGURATION AND PINOUTS

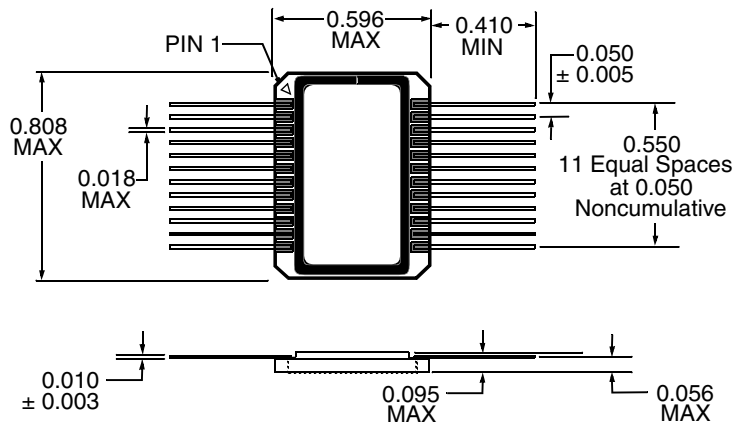

PLAINVIEW, NEW YORK
 Toll Free: 800-THE-1553
 Fax: 516-694-6715

INTERNATIONAL
 Tel: 805-778-9229
 Fax: 805-778-1980

NORTHEAST
 Tel: 603-888-3975
 Fax: 603-888-4585

SE AND MID-ATLANTIC
 Tel: 321-951-4164
 Fax: 321-951-4254

WEST COAST
 Tel: 949-362-2260
 Fax: 949-362-2266

CENTRAL
 Tel: 719-594-8017
 Fax: 719-594-8468



www.aeroflex.com info-ams@eroflex.com

Aeroflex Microelectronic Solutions reserves the right to change at any time without notice the specifications, design, function, or form of its products described herein. All parameters must be validated for each customer's application by engineering. No liability is assumed as a result of use of this product. No patent licenses are implied.



Our passion for performance is defined by three attributes represented by these three icons: solution-minded, performance-driven and customer-focused