

## Standard Products

# ACT4444 Transceiver for MIL-STD-1553/MACAIR in a Chipscale Package

Preliminary

October 1, 2003



## FEATURES

- ❑ Transceiver meets MIL-STD-1553A & B, Macair A3818, A4905, A5232 and A5690 specs
- ❑ Bipolar Supply  $\pm 15V$  to  $\pm 12V$ , Logic Supply +5V
- ❑ Replacement for function of CT3232 & ACT4404 in new designs
- ❑ Voltage source output
- ❑ Monolithic construction
- ❑ Aeroflex is a Class H & K MIL-PRF-38534 Manufacturer
- ❑ Miniature Chipscale Package Bumped Chip Carrier™ (BCC++)

NOTE: BCC++ and Bumped Chip Carrier are Trademarks of Fujitsu Ltd.

## GENERAL DESCRIPTION

The Aeroflex Laboratories transceiver model ACT4444 is a monolithic transceiver which provides full compliance with Macair and MIL-STD-1553 data bus requirements. The model ACT4444 performs the front-end analog function of inputting and outputting data through a transformer to a MIL-STD-1553 or Macair data bus with a few external components.

The ACT4444 can be considered a "Universal" Transceiver in that it is compatible with MIL-STD-1553A, B, Macair A-3818, A-4905, A-5232 and A-5690.

Design of these transceivers reflects particular attention to active filter performance. This results in low bit and word error rate with superior waveform purity and minimal zero crossover distortion. The ACT4444 active filter design has additional high frequency roll-off to provide the required Macair low harmonic distortion waveform without increasing the pulse delay characteristics significantly.

Efficient transmitter electrical and thermal design provides low internal power dissipation and heat rise at high and well as low duty cycles.

An optional receiver input threshold adjustment can be accomplished by the use of the "External Threshold" terminals.

## TRANSMITTER

The Transmitter section accepts bi-phase TTL data at the input and when coupled to the data bus with a 1:1 transformer, isolated on the data bus side with two 55 Ohm fault isolation resistors, and loaded by two 70 thru 85 Ohm terminations plus additional receivers, the data bus signal produced is 7.0 Volts minimum P-P at A-A' (See Figure 3 or 4). When both DATA and  $\overline{\text{DATA}}$  inputs are held low or high, the transmitter output becomes a high impedance and is "removed" from the line. In addition, an overriding "INHIBIT" input provides for the removal of the transmitter output from the line. A logic "1" applied to the "INHIBIT" takes priority over the condition of the data inputs and disables the transmitter (See Transmitter Logic Waveforms - Figure 1).

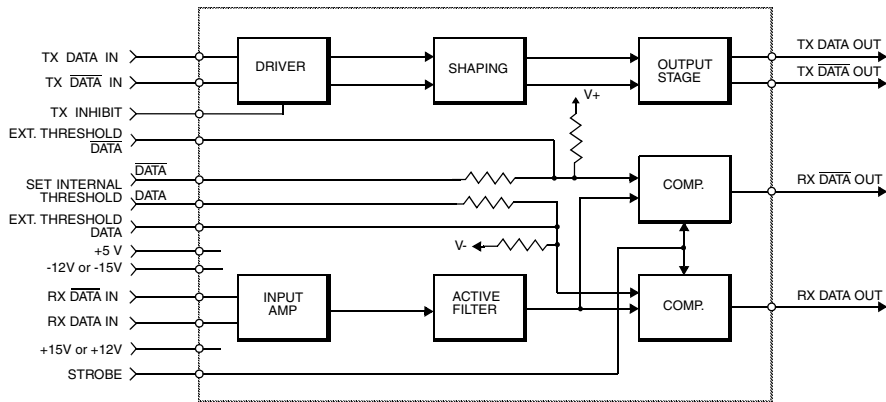
The transmitter utilizes an active filter to suppress harmonics above 1 MHz to meet Macair specifications A-3818, A-4905, A-5232 and A-5690. The transmitter may be safely operated for an indefinite period at 100% duty cycle into a data bus short circuit.

## RECEIVER

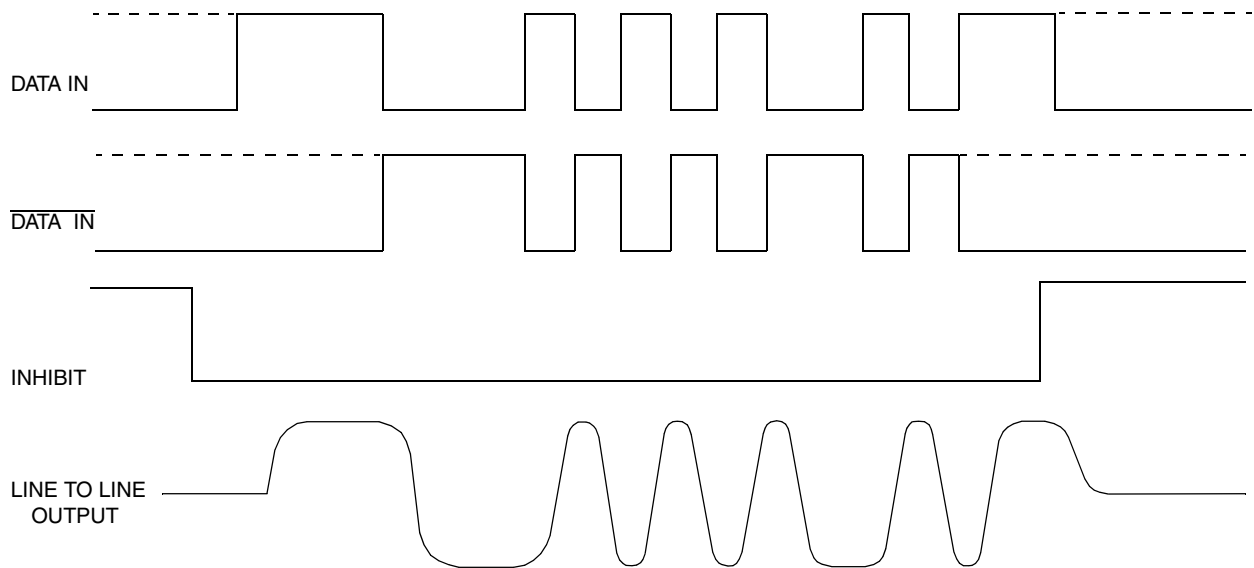
The Receiver section accepts bi-phase differential data at the input and produces two TTL signals at the output. The outputs are DATA and  $\overline{\text{DATA}}$ , and represent positive and negative excursions of the input beyond a pre-determined threshold (See Receiver Logic Waveforms - Figure 2).

The internal threshold is nominally set to detect data bus signals exceeding 1.05 Volts P-P and reject signals less than 0.6 Volts P-P when used with a 1:1 turns ratio transformer (See Figure 3 or 4 for transformer data and typical connections). This threshold setting can be held by grounding the appropriate pins or modified with the use of external resistors.

A low level at the Strobe input inhibits the DATA and  $\overline{\text{DATA}}$  outputs. If unused, a 2K Ohm pull-up to +5 Volts is recommended.

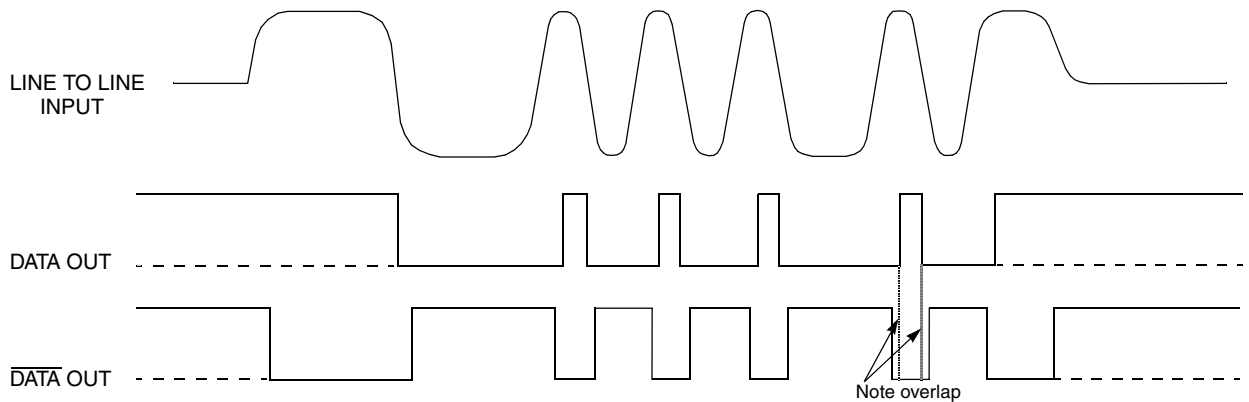


**BLOCK DIAGRAM (WITHOUT TRANSFORMER)**



- Notes:
1. Line to line waveforms illustrate Macair signals, MIL-STD-1553 signals are trapezoidal.
  2. DATA and  $\overline{\text{DATA}}$  inputs must be complementary waveforms or 50% duty cycle average, with no delays between them.
  3. DATA and  $\overline{\text{DATA}}$  must be in the same state during off time (both high or low).

**FIGURE 1 - TRANSMITTER LOGIC WAVEFORMS**



**FIGURE 2 - RECEIVER LOGIC WAVEFORMS  
NORMALLY HIGH OR LOW OUTPUT IN STANDBY (SEE FIGURE 3 OR 4)**

## ABSOLUTE MAXIMUM RATINGS

Operating Case Temperature	-40°C to +85°C	
Storage Case Temperature	-65°C to +150°C	
Power Supply Voltages	±16 V	+7 V
Logic Input Voltage	-0.3 V to +5.5 V	
Receiver Differential Input	±40 V	
Receiver Input Voltage (Common Mode)	±10V	
Driver Peak Output Current	150 mA	
Total Package Power Dissipation over the Full Operating Case Temperature Range *	3.25 Watts	
Maximum Junction to Case Temperature	3.25°C	
Junction-Case, Thermal Resistance	1°C/W	

\* See Aeroflex Application Note # 112 for reference.

## ELECTRICAL CHARACTERISTICS – TRANSMITTER SECTION 1/ 2/ INPUT CHARACTERISTICS, TX DATA IN OR TX DATA IN

Parameter	Condition	Symbol	Min	Typ	Max	Unit
"0" Input Current	$V_{IN} = 0.4 \text{ V}$	$I_{ILD}$	-	-0.2	-0.4	mA
"1" Input Current	$V_{IN} = 2.7 \text{ V}$	$I_{IHD}$	-	1.0	40	μA
"0" Input Voltage	-	$V_{IHD}$	-	-	0.7	V
"1" Input Voltage	-	$V_{IHD}$	2.0	-	-	V

## INHIBIT CHARACTERISTICS

"0" Input Current	$V_{IN} = 0.4 \text{ V}$	$I_{ILI}$	-	-0.2	-0.4	mA
"1" Input Current	$V_{IN} = 2.7 \text{ V}$	$I_{IHI}$	-	1.0	40	μA
"0" Input Voltage	-	$V_{ILI}$	-	-	0.7	V
"1" Input Voltage	-	$V_{IHI}$	2	-	-	V
Delay from TX inhibit(0→1) to inhibited output	-	$t_{DXOFF}$	-	300	500	nS
Delay from TX inhibit, (1→0) to active output	-	$t_{DXON}$	-	300	500	nS
Differential output noise, inhibit mode	3/	$V_{NOI}$	-	0.8	10	mVp-p
Differential output impedance *	4/	$Z_{OI}$	2K	-	-	Ω

\* See Aeroflex Application Note # 113 for reference.

## OUTPUT CHARACTERISTICS

Differential output - Direct coupled stub (See Figure 3 or 4)	Pt. B - B' $Z_O =$ 70Ω-85Ω 5/	$V_O$	26	29	32	$V_{p-p}$
Differential output offset - Direct coupled stub Figure 3 or 4		$V_{OS}$	-	-	±360	mVpk
Differential output rise / fall times (See Figure 5)	10% - 90%	$t_R$ & $t_F$	200	250	300	nS
Delay from 50% point of TX DATA or TX $\overline{\text{DATA}}$ input to zero crossing of differential output.	-	$t_{DTX}$		280	350	nS

## ELECTRICAL CHARACTERISTICS – RECEIVER SECTION 1/ 2/

Parameter	Condition	Symbol	Min	Typ	Max	Unit
Differential Input Impedance	f = 1MHz	Z <sub>IN</sub>	10K	-	-	Ω
Differential Input Voltage Range	-	V <sub>IDR</sub>	-	-	40	Vp-p
Input Common Mode Voltage Range	-	V <sub>ICR</sub>	10	-	-	Vp-p
Common Mode Rejection Ratio	-	CMRR	40	-	-	dB

### STROBE CHARACTERISTICS (LOGIC "0" INHIBITS OUTPUT)

"0" Input Current	V <sub>S</sub> = 0.4 V	I <sub>IL</sub>	-	-0.2	-0.4	mA
"1" Input Current	V <sub>S</sub> = 2.7 V	I <sub>IH</sub>	-	1.0	+40	μA
"0" Input Voltage	-	V <sub>IL</sub>	-	-	0.7	V
"1" Input Voltage	-	V <sub>IH</sub>	2.0	-	-	V
Strobe Delay (Turn-on or Turn-off)	-	t <sub>SD</sub>	-	-	250	nS

### THRESHOLD CHARACTERISTICS (SINEWAVE INPUT)

Internal Threshold Voltage (See Figure 3 or 4)	Pt. B - B' 1MHz	V <sub>TH</sub>	0.60	0.80	1.10	Vp-p
---	--------------------	-----------------	------	------	------	------

### OUTPUT CHARACTERISTICS, RX DATA AND RX $\overline{\text{DATA}}$

"1" State	I <sub>OH</sub> = -0.4 mA	V <sub>OH</sub>	2.5	3.6	-	V
"0" State	I <sub>OL</sub> = 4 mA	V <sub>OL</sub>	-	0.35	0.5	V
Delay (average), from differential input zero crossings to RX DATA and RX $\overline{\text{DATA}}$ output 50% points	$\underline{6}$	t <sub>DRX</sub>	-	300	500	nS

## POWER SUPPLY CURRENT 1/ 2/

Duty Cycle	Condition	Symbol	Typ	Max	Unit
Transmitter Standby	Pt. B - B', Z <sub>O</sub> = 70 Ω, V <sub>O</sub> = 29 VPK-PK Bit Pattern = FFFF <sub>HEX</sub> Figure 3 or 4	I <sub>CC</sub>	5	10	mA
		I <sub>EE</sub>	25	35	
		I <sub>L</sub>	18	30	
25%		I <sub>CC</sub>	20	30	
	I <sub>EE</sub>	40	60		
	I <sub>L</sub>	18	30		
50%	I <sub>CC</sub>	40	60		
	I <sub>EE</sub>	60	80		
	I <sub>L</sub>	18	30		
100%	I <sub>CC</sub>	85	120		
	I <sub>EE</sub>	105	140		
	I <sub>L</sub>	18	25		

## TYPICAL HYBRID POWER DISSIPATION \*

Power Supply Conditions	Condition	Standby	100% Duty Cycle	Unit
PSC1 V <sub>CC</sub> = +15V V <sub>EE</sub> = -15V V <sub>L</sub> = +5V	Pt. B - B', Z <sub>O</sub> = 70 Ω, V <sub>O</sub> = 29 V <sub>PK-PK</sub> Bit Pattern = FFFF <sub>HEX</sub> Figure 3 or 4	0.540	2.167	Watts
PSC2 V <sub>CC</sub> = +15V V <sub>EE</sub> = -12V V <sub>L</sub> = +5V		0.465	1.852	
PSC3 V <sub>CC</sub> = +12V V <sub>EE</sub> = -12V V <sub>L</sub> = +5V		0.450	1.600	

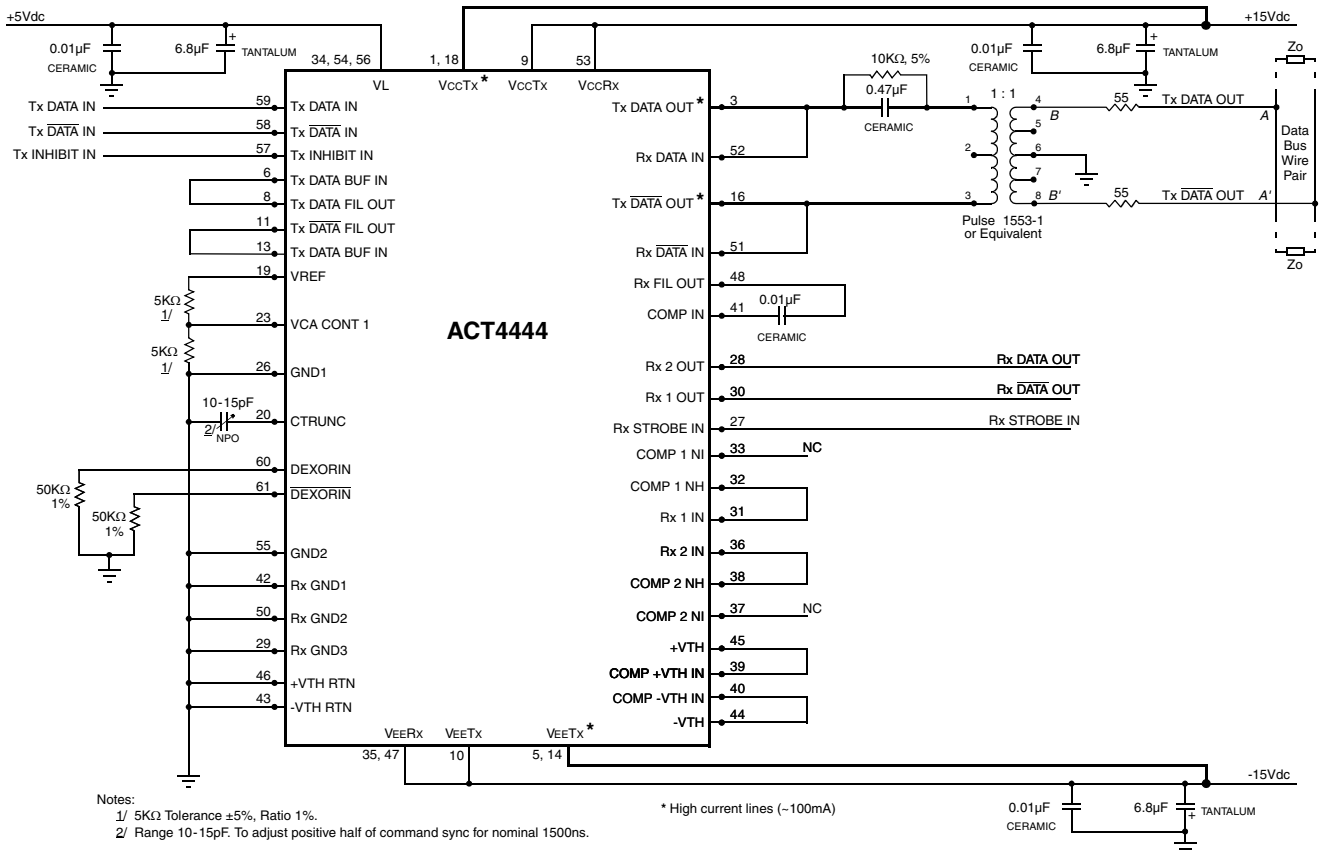
\* See Aeroflex Application note# 112 for reference.

## RECOMMENDED POWER SUPPLY VOLTAGE RANGE

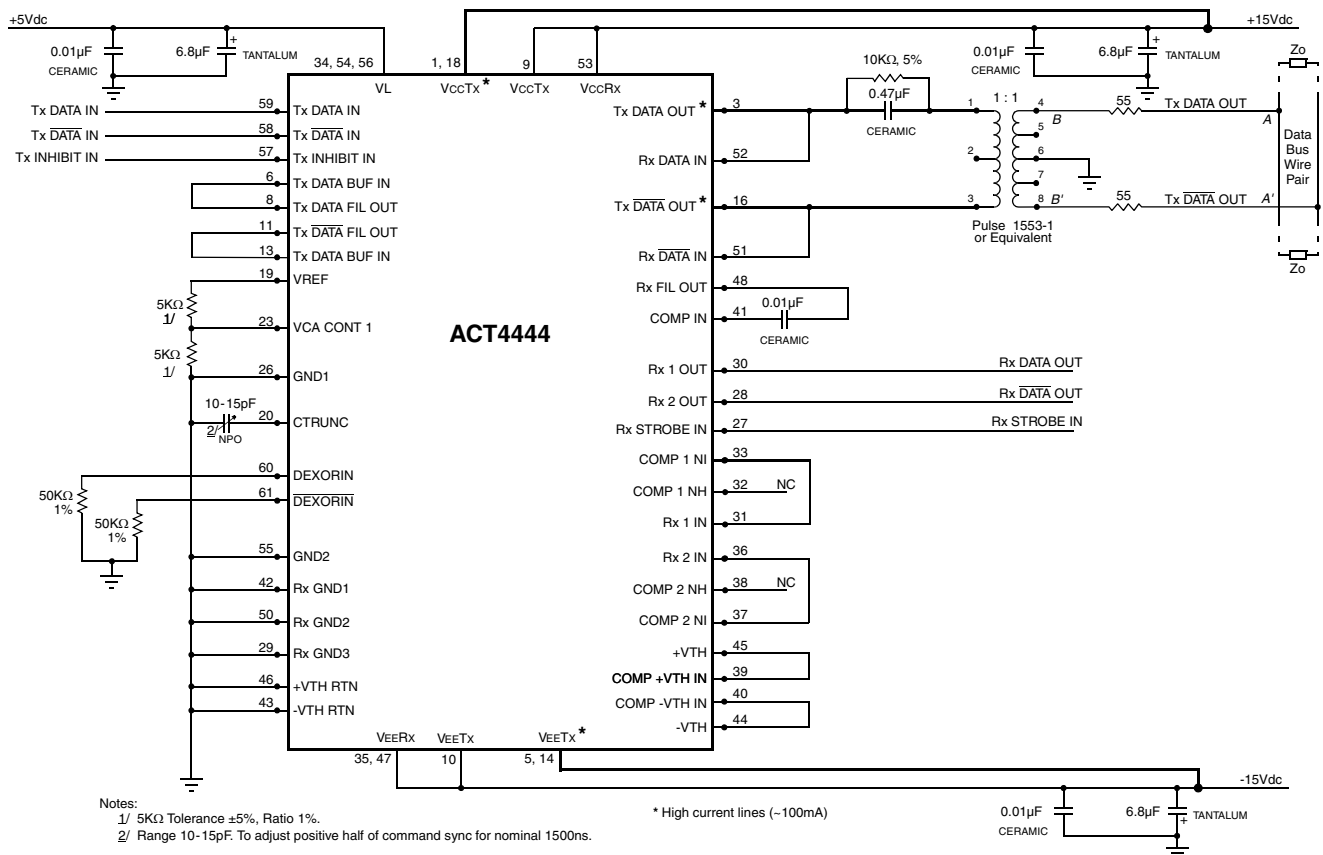
V <sub>CC</sub>	+11.4 Volts to +15.75 Volts
V <sub>EE</sub>	-11.4 Volts to -15.75 Volts
V <sub>L</sub>	+4.5 Volts to +5.5 Volts

Notes:

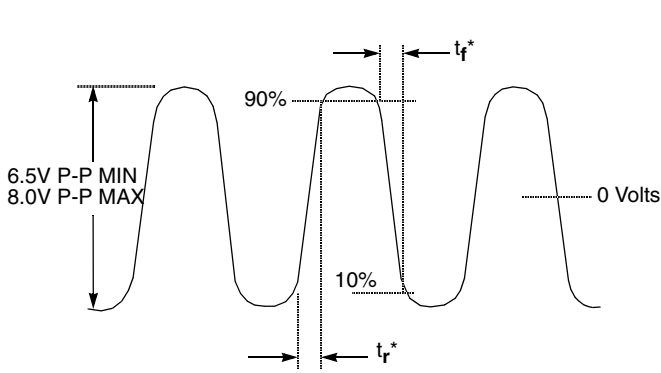
1. V<sub>CC</sub> = +15Volts ±0.75V, V<sub>EE</sub> = -15Volts ±0.75V, V<sub>L</sub> = +5Volts ±0.5V, T<sub>C</sub> = -40°C to +85°C, unless otherwise specified.
2. All typical values are measured at +25°C.
3. Characteristics guaranteed by design, not production tested.
4. Power ON/OFF, measured from 75KHz to 1MHz at Point A-A' Figure 3 or 4, in accordance with MIL-STD-1553B paragraph 4.5.2.2.2.3.
5. At point A-A' on Figure 3 or 4, 2.5µS after midpoint crossing of the parity bit of the last word of a 660 µS message.
6. This test is performed while the Transceiver is reading its own transmission. This condition is called "Wraparound". Standard TTL loads applied to RX DATA Outputs.



**FIGURE 3 – TYPICAL CONNECTIONS – DATABUS INTERFACE, DIRECT COUPLED STUB, NORMALLY HIGH RECEIVER IDLE STATE**

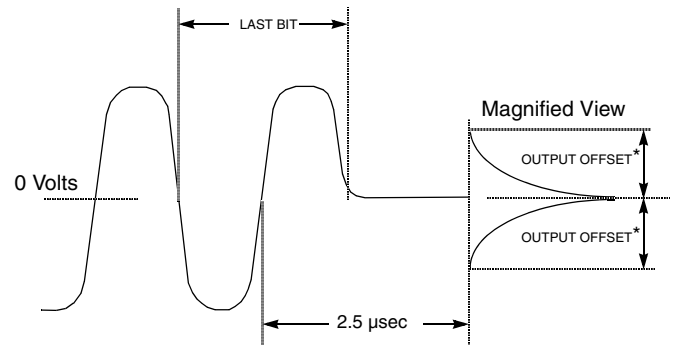


**FIGURE 4 – TYPICAL CONNECTIONS – DATABUS INTERFACE, DIRECT COUPLED STUB, NORMALLY LOW RECEIVER IDLE STATE**



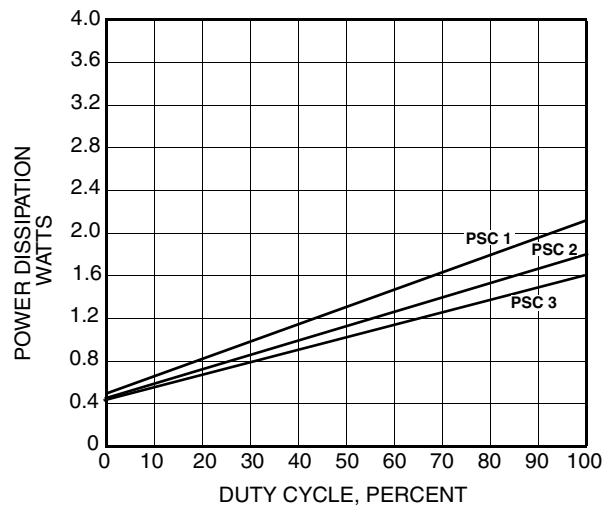
\* Rise and fall times measured at point A-A' in Figure 3 or 4

**FIGURE 5 – TRANSMITTER (TX) OUTPUT WAVE FORM**



\*Offset measured at point A-A' in Figure 3 or 4

**FIGURE 6 – TRANSMITTER (TX) OUTPUT OFFSET**



**FIGURE 7 – TYPICAL HYBRID POWER DISSIPATION vs DUTY CYCLE**

## PACKAGE PIN OUT DESCRIPTION - ACT4444

Pin #	Function	Pin #	Function
1	V <sub>CC</sub> Tx*	33	COMP 1 NL
2	NC	34	V <sub>L</sub>
3	TX DATA OUT*	35	VEERx
4	NC	36	RX 2 IN
5	VEETx*	37	COMP 2 NL
6	TX DATA BUF IN	38	COMP 2 NH
7	VCA DATA OUT	39	COMP +VTH IN
8	TX DATA FIL OUT	40	COMP -VTH IN
9	V <sub>CC</sub> Tx	41	COMP IN
10	VEETx	42	RX GND 1
11	TX $\overline{\text{DATA}}$ FIL OUT	43	-VTH RTN
12	VCA $\overline{\text{DATA}}$ OUT	44	-VTH
13	TX $\overline{\text{DATA}}$ BUF IN	45	+VTH
14	VEETx*	46	+VTH RTN
15	NC	47	VEERx
16	TX $\overline{\text{DATA}}$ OUT*	48	RX FIL OUT
17	NC	49	NC
18	V <sub>CC</sub> Tx*	50	RX GND 2
19	VREF	51	RX $\overline{\text{DATA}}$ IN
20	CTRUNC	52	RX DATA IN
21	NC	53	V <sub>CC</sub> Rx
22	NC	54	V <sub>L</sub>
23	VCA CONT1	55	GND 2
24	NC	56	V <sub>L</sub>
25	NC	57	TX INHIBIT IN
26	GND 1	58	TX $\overline{\text{DATA}}$ IN
27	RX STROBE IN	59	TX DATA IN
28	RX 2 OUT	60	DEXORIN
29	RX GND 3	61	$\overline{\text{DEXORIN}}$
30	RX 1 OUT	62	NC
31	RX 1 IN	63	NC
32	COMP 1 NH	64	NC

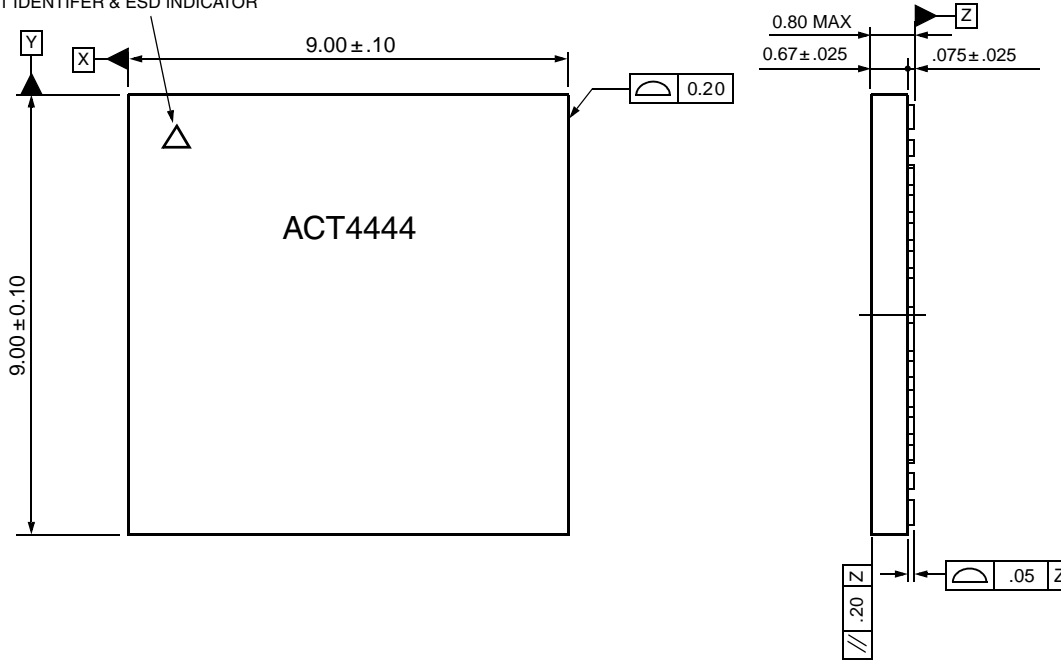
NC = No Connect

\* High Current Line (~100mA)

# PACKAGE DESCRIPTION

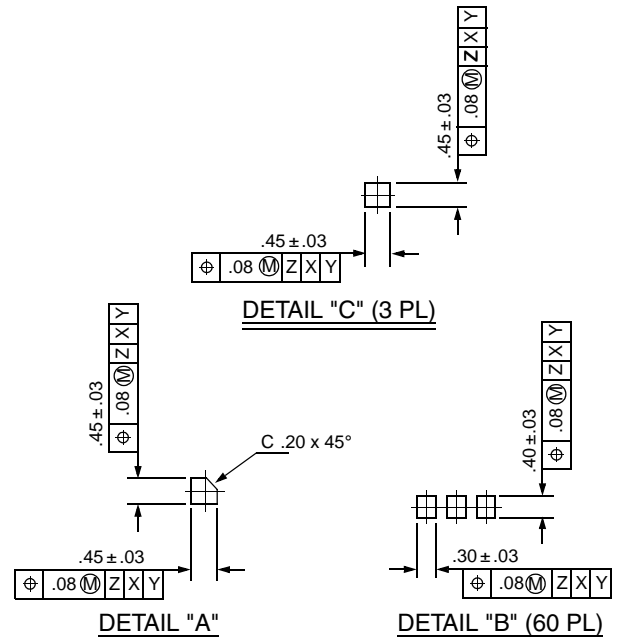
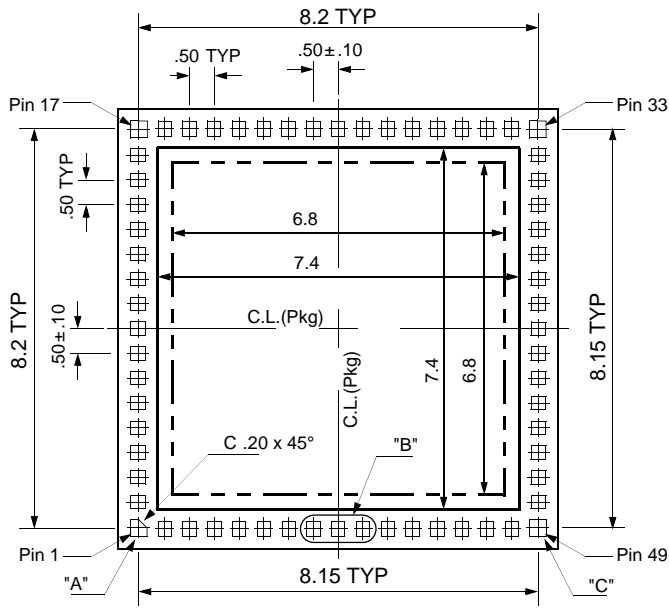
## TOP VIEW

PIN 1 IDENTIFER & ESD INDICATOR



MM	Inches
9	.354
8.2	.323
8.15	.321
0.8	.0315
0.67	.026
0.5	.020
0.45	.018
0.3	.012
0.2	.008
0.1	.00394
0.08	.00315
0.075	.00295
0.05	.002
0.03	.0012
0.025	.001
0.020	.0008

## BOTTOM VIEW



Notes  
1. Dimensions in millimeters

## CONFIGURATIONS AND ORDERING INFORMATION

Model No.	Screening Level	Receiver And Transmitter Data Levels	Package
ACT4444	Industrial Temperature -40°C to +85°C	User Configurable (See Figure 3 & 4)	64 Bump Chip Carrier

**PLAINVIEW, NEW YORK**  
Toll Free: 800-THE-1553  
Fax: 516-694-6715

**INTERNATIONAL**  
Tel: 805-778-9229  
Fax: 805-778-1980

**NORTHEAST**  
Tel: 603-888-3975  
Fax: 603-888-4585

**SE AND MID-ATLANTIC**  
Tel: 321-951-4164  
Fax: 321-951-4254

**WEST COAST**  
Tel: 949-362-2260  
Fax: 949-362-2266

**CENTRAL**  
Tel: 719-594-8017  
Fax: 719-594-8468

***www.aeroflex.com info-ams@aeroflex.com***

Aeroflex Microelectronic Solutions reserves the right to change at any time without notice the specifications, design, function, or form of its products described herein. All parameters must be validated for each customer's application by engineering. No liability is assumed as a result of use of this product. No patent licenses are implied.



Our passion for performance is defined by three attributes represented by these three icons: solution-minded, performance-driven and customer-focused