

## Universal Evaluation Kit For Single Frequency FM Radio Modules

*This Evaluation Kit can be used to evaluate single frequency Radiometrix VHF/UHF transmitter, receiver and transceiver modules. LED indicators are provided to show system status and to facilitate range testing and site surveys. The board is controlled by the Eval-RPC chip and incorporates several useful diagnostics & debug modes. Link-selectable 9.6kbps or 64kbps data rate.*

### Range of facilities include:

- Range Testing
- Target Environment Testing
- Noise and Interference Identification
- Antenna Evaluation
- Transient Analysis
- Communication Eye Diagram
- Analogue and digital data transmission
- TX1(H)/HX1/RX1, NTX2/NRX2, TX2(A)/TX2H/RX2(A), TX3A/RX3A, BiM1T/ BiM1R, CVR1, BiM/1/2/3A and NiM2 hardware test
- Received Signal Strength Indicator (RSSI) meter
- Linking external hardware directly or via on board Eval RPC
- Responses up to 9.6kbps (A) or 64 kbps (F)



*Universal Evaluation Board*

The Eval-RPC is based upon a modified RPC-000-DIL design and provides management of all the necessary data and control lines. The user can define both operational mode and data bit rate simply by selecting the required positions on the provided DEBUG switch and the various jumpers. Indication of unit status is provided by means of LEDs for Power, Transmit, Receive, Carrier Detect, Signal and OK (link success) functions.

### Check List

The Universal Evaluation Kit should include the following components and documentation:

- 2 Analogue input/output boards
- 2 Parallel port interface adaptor
- 2 9V battery (PP3)
- 2 1/4 wavelength whip for 433MHz, 869/914MHz and helical antennas for 173MHz
- 2 10.24MHz crystals for 40kbps operation
- 2 FRPC-000-DIL (optional)
- 2 20.48MHz crystals for 160kbps operation (optional)

In addition to the above a 2-channel (or even better, a 4-channel) digital storage oscilloscope is highly recommended as a means of monitoring system operation.

## Visual Facilities

The following status LEDs will be activated depending on which mode is selected:

LED	Indication
TX (Red):	Transmitter enabled
RX (Green):	Receiver enabled
CD (Orange):	Carrier / Interference detected
SIGNAL (bright Red):	Preamble detected
OK (bright Yellow):	Valid packet received / Test passed

The Received Signal Strength Indicator (RSSI) meter on the analogue I/O board provides an indication of the received RF signal power level, useful in range testing and when checking for interference.

## Diagnostic Modes

Mode	Name	Function
0	RX-ON	Preamble detector on (SIGNAL LED lit = preamble detected)
1	RX-PULSE	7ms on: 10ms off, preamble detector on SIGNAL LED
2	TX-ON-PRE	Preamble modulation – send continuous preamble on TX
3	TX-ON-SQ	100Hz square wave modulation, for TX testing using spectrum analyser, etc.
4	TX-ON-255	256 bit pseudo-random data for eye diagram tests, sync on RXR
5	TX-PULSE	8ms on / 8ms off, preamble bursts for Rx lock-in tests
6	ECHO	Transponder mode, unit re-transmits any valid packets received
7	RADAR	Send ASCII test packet “Universal Eval Kit XX” and listen for echo
8	SELF-TEST	Local loop test, TX → RX (OK on RXR)
9 to E		For future updates on additional Modes, check the Radiometrix web site: <a href="http://www.radiometrix.co.uk/products/uniek.htm">www.radiometrix.co.uk/products/uniek.htm</a>
F	Normal RPC	Normal Eval RPC mode allows external host microcontroller or PC interface

## Jumper Links

Jumper Link	Function
LK1	Short TXR with 0V pin to enter diagnostic modes.
LK2	Select the data rate according to module requirements: Across left & middle pins (A position) for 9.6kbps, Across middle & right pins (F position) for 64kbps.
LK3	Remove to disconnect Eval-RPC data from the module TXD line when using external analogue / digital data or to transmit unmodulated carrier.
LK4	Insert to reduce Eval-RPC drive amplitude to module TXD from 0-5V to 0-3V. e.g. TX1(H), NTX2, TX3A, BiM1 and BiM3A. LK5 should also be removed
LK5	Insert to operate with standard 0-5V Eval-RPC drive amplitude. LK4 should also be removed
LK6	Insert to enable Carrier Detect LED (For RX2, BiM/BiM2 only).

## LK1

Eval RPC has two modes of operation:

- 1) Normal mode (Jumper removed)
- 2) Diagnostic mode (Jumper inserted)

In normal mode, the Eval-RPC behaves similarly to a Radio Packet Controller (RPC). The board can be used in conjunction with a host microcontroller or PC to transmit & receive packetised data. Diagnostic mode can be used to evaluate system performance in the intended environment.

## LK2

This link connects the appropriate crystal to the Eval-RPC oscillator circuit for data bit rate selection.

### Crystal Frequency

All timings within the Eval RPC (except sleep) are determined by the clock frequency. The standard frequencies are 2.4576MHz and 16.384MHz.

$$\text{Data Rate} = \frac{f_{\text{crystal}}}{256} \text{ bps}$$



**Figure 1: Jumper selection for data rate**

When the Jumper is placed as shown on the above left diagram, 2.4576MHz, the Eval RPC will transmit data at 9.6kbps.

$$\text{Data rate} = \frac{2.4576 \times 10^6}{256} = 9600 \text{ bps}$$

$$\text{Data rate} = \frac{16.384 \times 10^6}{256} = 64000 \text{ bps}$$

TX2/RX2 and BiM module performance at 40kbps can be evaluated by replacing one of the standard crystals with the 10.24MHz unit supplied.

## LK3

The module TXD line is normally driven directly with data from the Eval-RPC chip. However, it can also be driven from an external digital or analogue source if required. In this case, removing LK3 allows the TXD line to be disconnected from the internal Eval-RPC data for correct operation.

## LK4

The TX2, HX1, BiM and BiM2 operate on 5V supply and hence their TXD input can be in 0-5V range. However, TX1, NTX2, TX3A, BiM1 and BiM3A operate internally on 3V supply and their data input should be in 0-3V range.

This LK4 jumper link grounds the R4, making a parallel connection to the TXD input.

Very high input impedance of TXD with R4 resistor in parallel combination will give effective impedance equivalent to R4 (3.3k) resistor. R3 (2.2k) and R4 (3.3k) will form a potential divider reducing the logic level from 0-5V to 0-3V range. LK5 jumper should be removed while LK4 jumper link is inserted

$$V_{\text{TXD}} = \frac{3.3\text{k}\Omega}{3.3\text{k}\Omega + 2.2\text{k}\Omega} \times 5\text{V} = 3\text{V}$$

## **LK5**

Removing the LK4 jumper and linking the LK5 returns the Eval-RPC drive amplitude of module TXD back to 0-5V

## **LK6**

The RX2 and BiM/BiM2 modules have Carrier Detect (CD) output instead of RSSI output featured on RX1, RX2A, NRX2, RX3A, BiM1 and BiM3A modules. Inserting the LK6 will enable the CD LED to work with RX2 and BiM/BiM2 modules. It should be removed when evaluating modules with RSSI output and CD LED output should also be ignored.

## Diagnostic Modes

To enter the DEBUG mode, Jumper Link (LK1) (below the 9V battery) should be connected across TXR and 0V pin. The RESET button should be pressed while the Jumper Link is connected across TXR and 0V.

**Note:** All the Oscilloscope screen capture and Spectrum Analyser screen capture given on the manual are instantaneous and they will vary with time.

### Mode 0 - Preamble Detector

*Applies to Evaluation Kit with Receiver:*

Insert Receiver module in one of the Evaluation Kit and Transmitter module on another. Transmitting and Receiving unit should operate at same data rate. i.e. LK2 position on both evaluation kit should be same position on both evaluation kits. If the jumper LK2 is at position A, the preamble will be a 4.8kHz or 9.6kbps square wave signal.

In this mode, receiver is continuously powered up (RX LED on) and if preamble, 32kHz or 64kbps square wave signal, with jumper LK2 at position F, is detected the SIGNAL line is pulled low lighting the SIGNAL LED. RXR will also be pulled low lighting the OK LED to indicate that valid preamble was received.

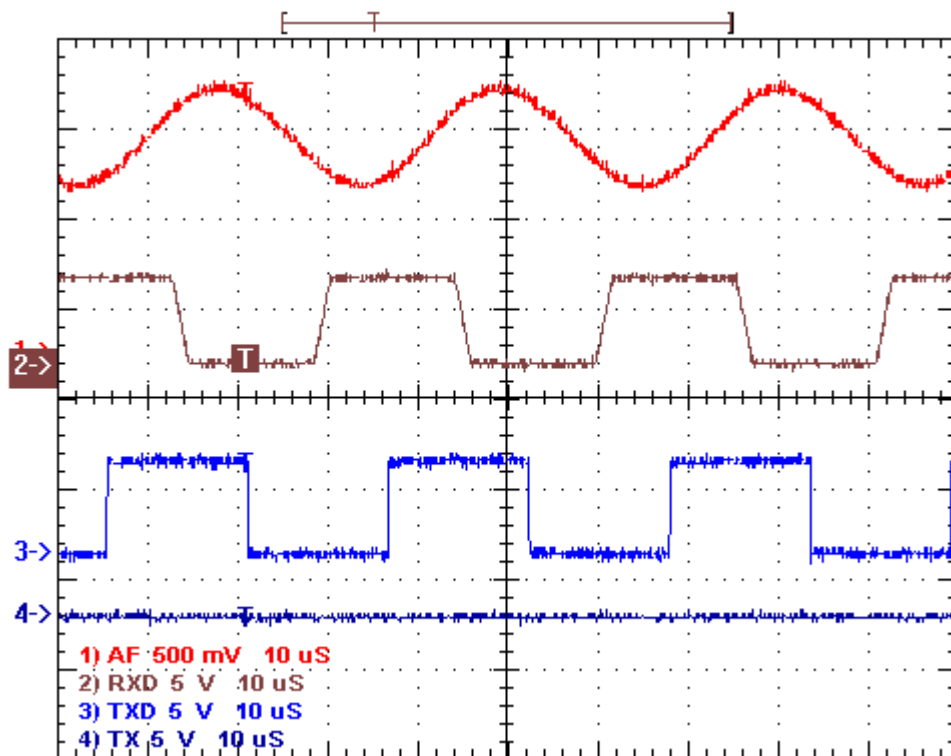

**Figure 2: transmitted and received preamble (64kbps square wave signal)**

In the above screen capture of a 4-channel oscilloscope:

An Evaluation Kit with Transmitter is powered on (TX LED on) continuously (Mode 2) to transmit preamble. The TX line is held low (blue TX waveform) by the Eval-RPC and it feeds 32kHz square wave signal into TXD pin (green TXD waveform) of the Transmitter. Oscilloscope is triggered on TXD.

Other Evaluation Kit with Receiver is also powered on (green RX LED on) continuously (Mode 0). AF output (red AF waveform) and RXD output (brown RXD waveform) are monitored.

The AF output is at 1.16V DC with about 240mV AC sine wave, which is digitised by the Adaptive Data Slicer in the Receiver to re-produce the received preamble. (Ground level of AF is at the bottom of the screen)

**Note:** LK3 should be removed when connecting analogue I/O board.

### Mode 1 - Pulsed Receiver

*Applies to Evaluation Kit with Receiver:*

Receiver is switched on for about 7ms and Eval RPC checks for preamble. If preamble is detected the SIGNAL line is pulled low. This will light up the SIGNAL LED. If not, the Receiver is turned off for about 10ms and the process is repeated. OK LED will also light up if a valid Preamble is detected.

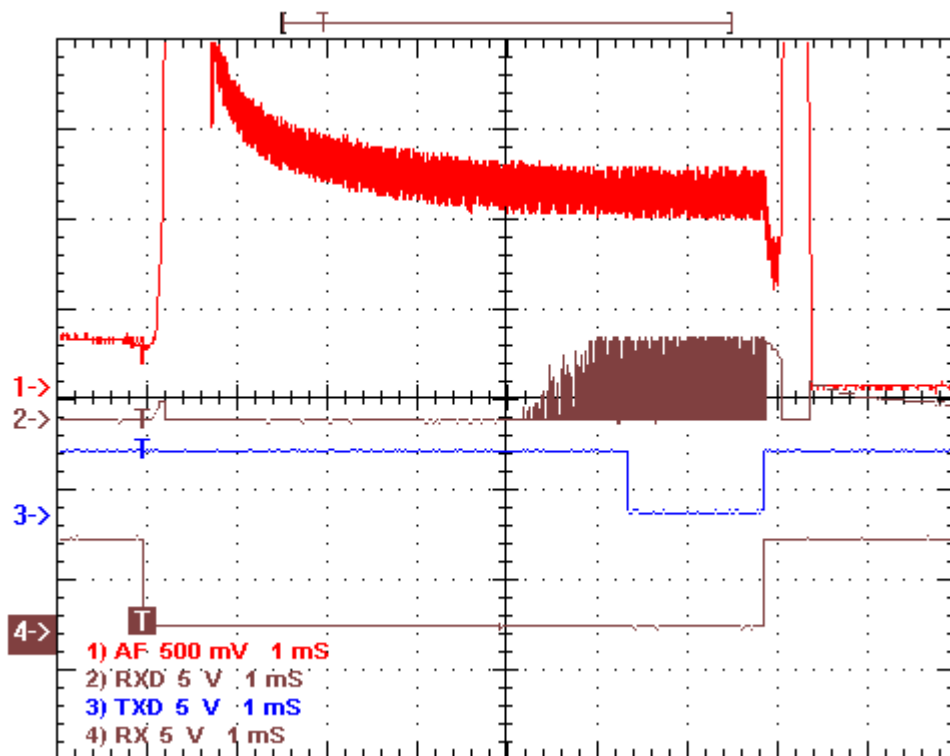

**Figure 3: receiver power up to valid data timing measurement**

This mode can be used to test the power up time and settling time of the receiver module.

## Mode 2 - Transmit Preamble Modulation

*Applies to Evaluation Kit with Transmitter:*

Transmitter is turned on continuously and preamble is transmitted. This complement mode can be used with Mode 0 as a pair.

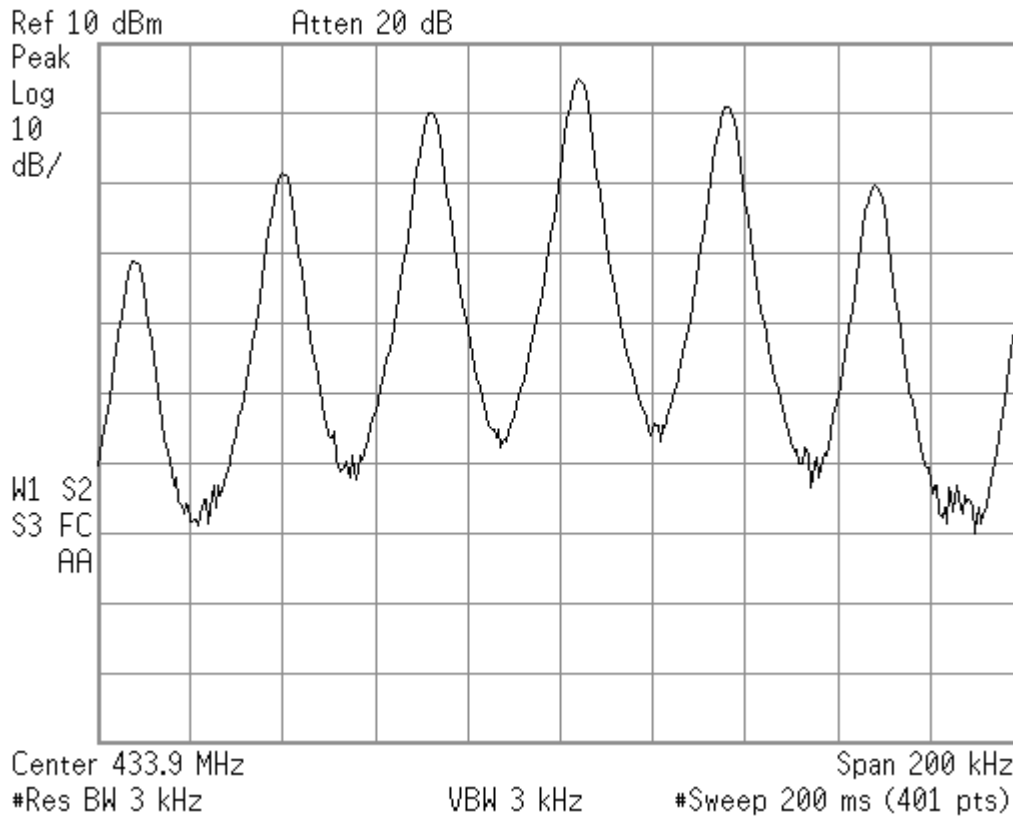

**Figure 4: Transmitter spectrum with 32kHz (64kbps) square wave modulation**

The above frequency spectrum shows a Carrier Frequency in the middle and FM side bands on both sides. Each side band is spaced 32kHz apart. This mode can also be used to measure modulation bandwidth at maximum data rate.

**Note:** Mode 2, with LK3 removed, can be also be used as TX On mode to switch on the transmitter, when feeding analogue signal or external data. LK3 should also be removed when analogue I/O board is connected.

### Mode 3 - Transmit 100Hz (200bps) square wave modulation

*Applies to Evaluation Kit with Transmitter*

Transmitter is turned on and the carrier is modulated by 100Hz or 200bps square wave signal. This mode can be used to test the Transmitter on a Spectrum Analyser. It can be used to measure RF power output, peak FM deviation and frequency offset.

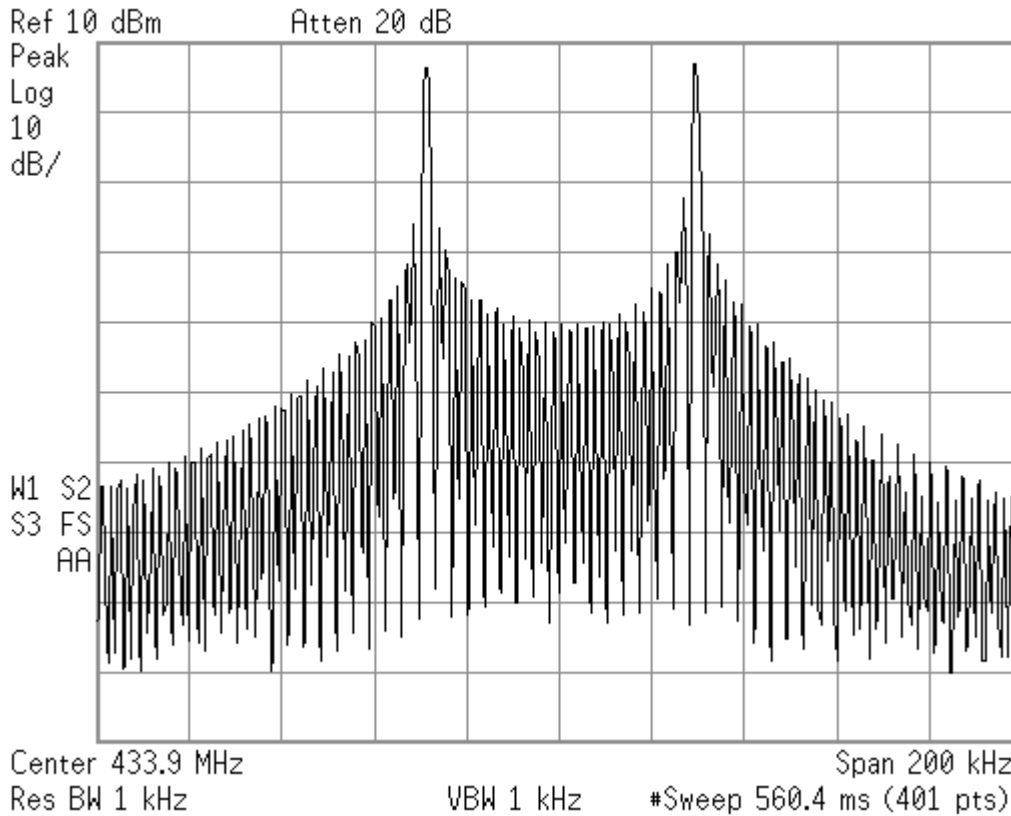

**Figure 5: TX2-433-40 transmitter spectrum with 100Hz (200bps) square wave modulation**

The RF output power on the above spectrum is the maximum peak value of about +10dBm. The above spectrum shows 2 prominent peaks. The peak to peak spacing is twice the peak FM deviation value. Left peak will be at same position as unmodulated carrier when TXD is at 0V. Right peak will be at the same position as unmodulated carrier when TXD is at 5V.

**Note:** Universal Eval Kit uses a common 50Ω microstrip track between transmitter, receiver, transceiver and the antenna connector, instead of an RF switch. Therefore, actual measured RF output power will appear to be few dB lower.

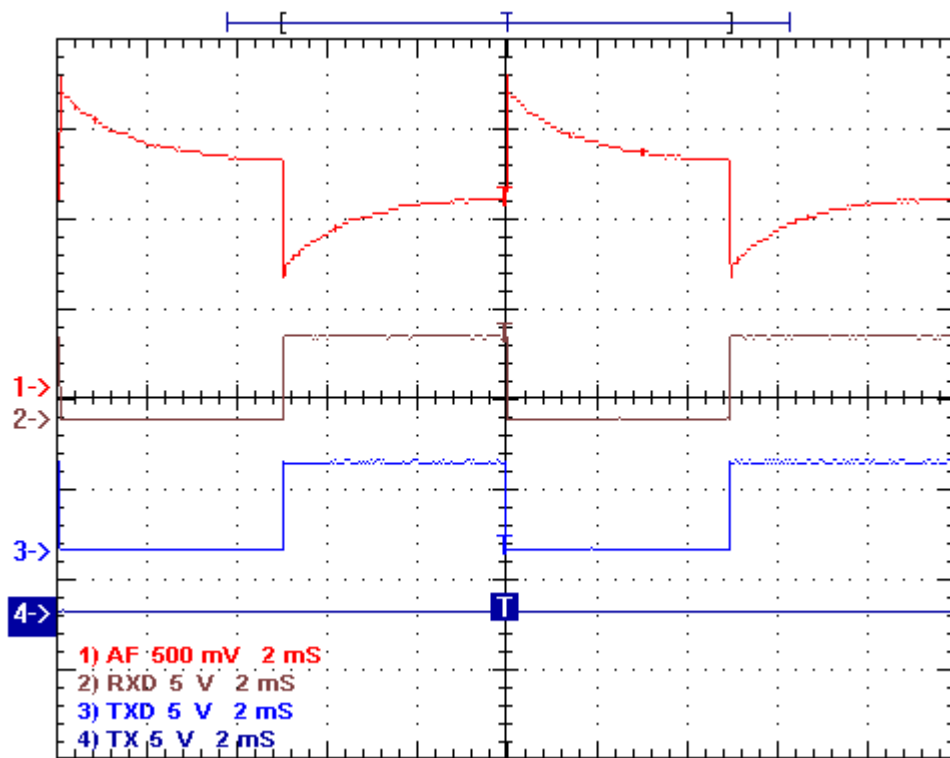

**Figure 6: transmitted and received 100Hz (200bps) square wave signal**

RF Carrier will not be modulated by the data from Eval RPC if the LK3 is removed. The spectrum of unmodulated carrier with TXD held at 0V is given below.

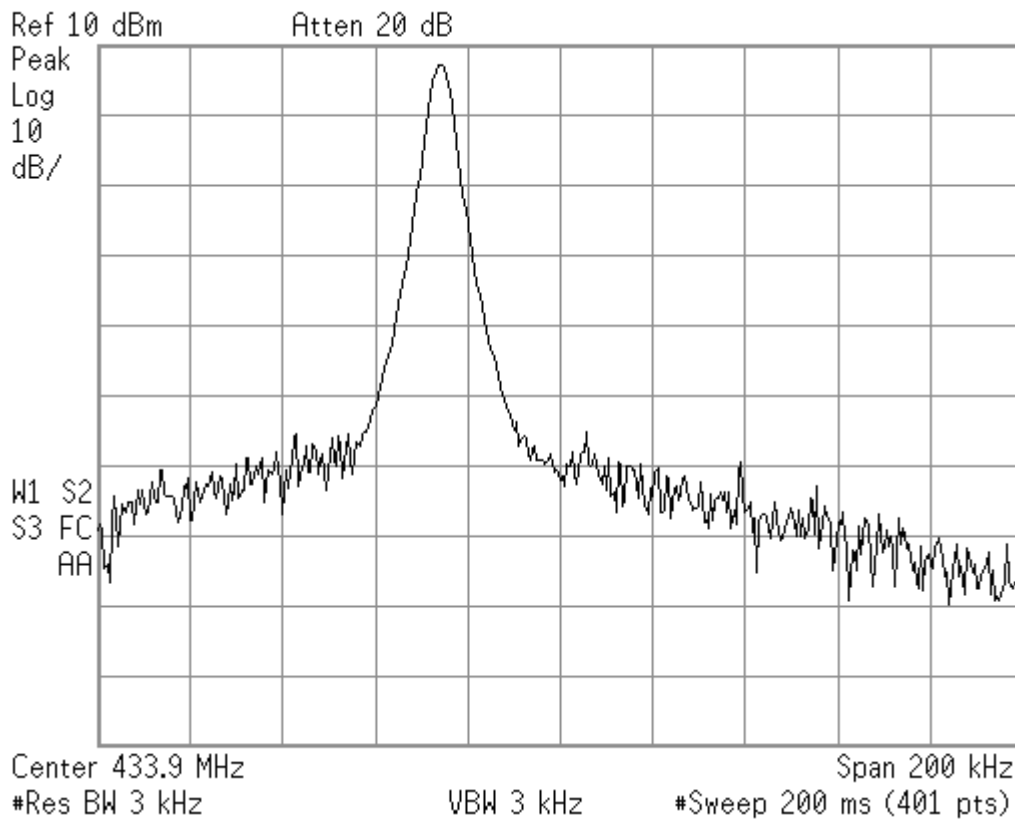

**Figure 7: unmodulated transmitter spectrum when TXD is at 0V**

It can be used to check the phase noise of the transmitter.

## Mode 4 - Transmit Random Code

*Applies to Evaluation Kit with Transmitter:*

Transmitter is turned on and the carrier is modulated by a 8 bit maximal length (255) pseudo-random code at  $15.6\mu\text{s}$  per bit (at 64kbps). On the receiving end, the data output AF line can be connected to an Oscilloscope to obtain an eye diagram.

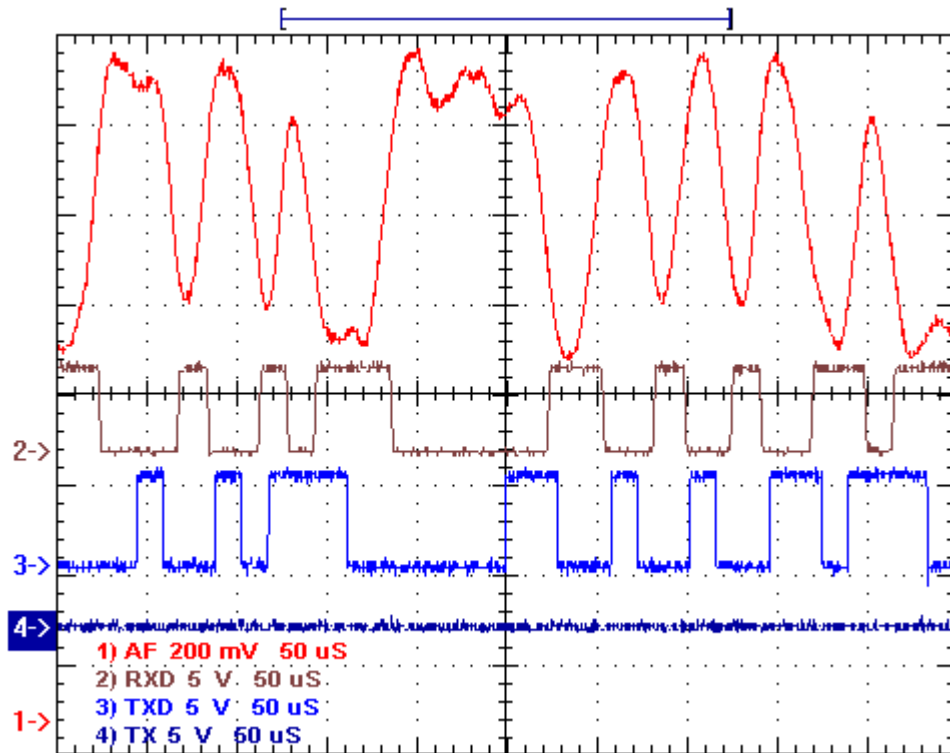

**Figure 8: transmitted and received pseudo-random code**

## Eye Diagram

An eye diagram is an oscilloscope display in which a pseudo-random analogue data signal from AF output of a receiver is repetitively sampled and applied to the vertical input, while the data rate (RXR) on the transmitting unit is used to trigger the horizontal sweep. The picture one obtains is a superposition of ones and zeros output.

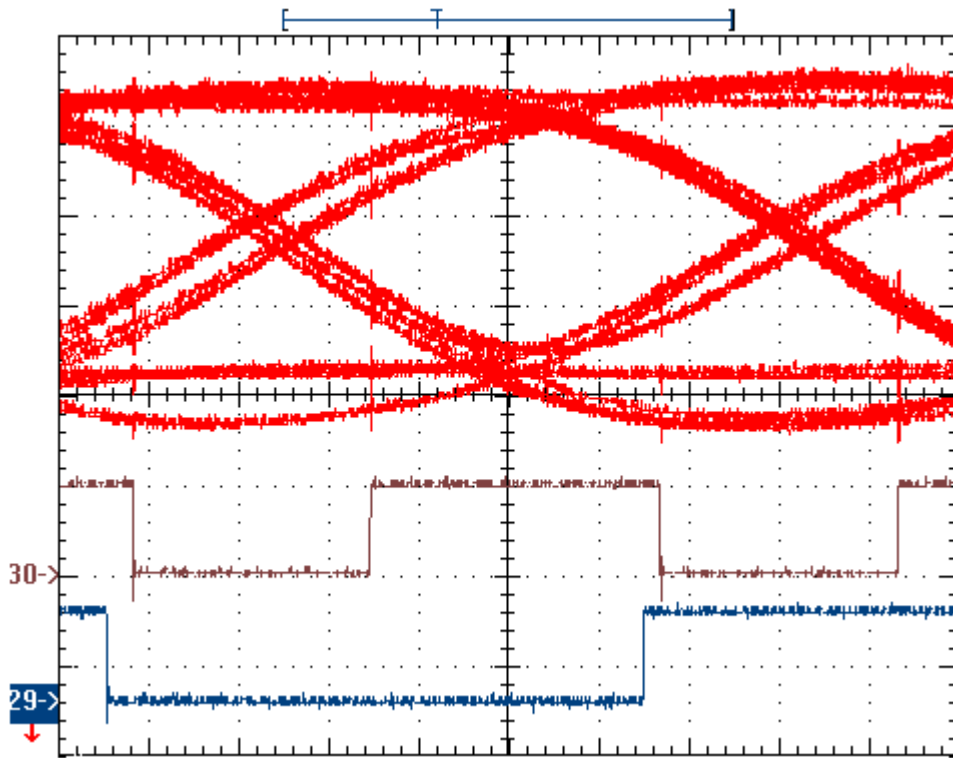

**Figure 9: eye diagram of receiver**

System performance information can be derived by analyzing the display. The horizontal width of the lines gives the jitter (phase noise) and the rise and fall times of the data pulses can be measured from the "crossings". An open eye pattern corresponds to minimal signal distortion. Distortion of the signal waveform due to intersymbol interference and noise appears as closure of the eye pattern.

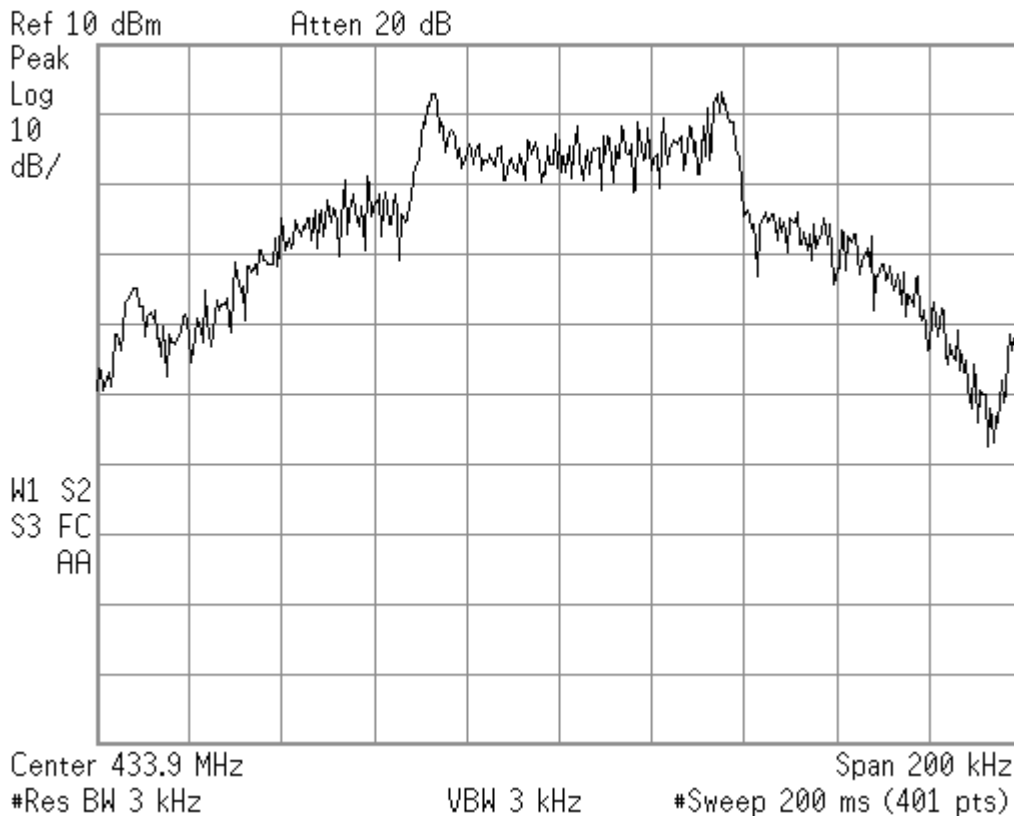
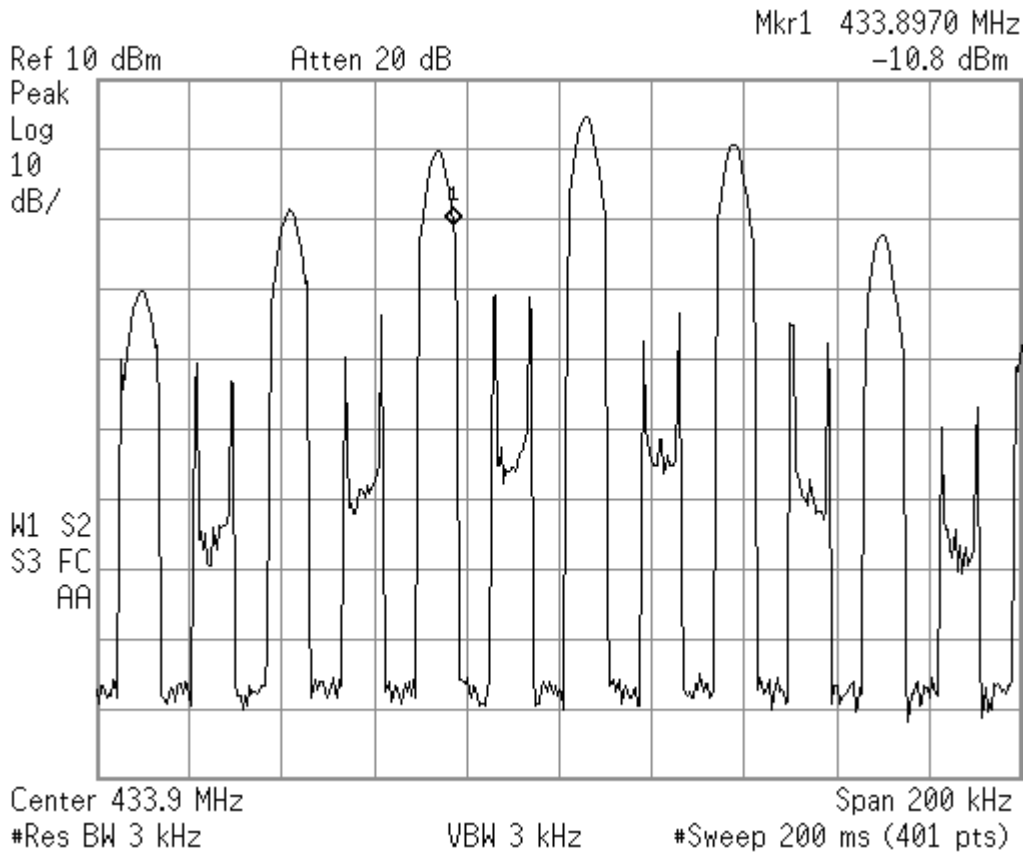

**Figure 10: spectrum of BiM2-433-64 when transmitting pseudo-random**

## Mode 5 - Pulsed Preamble Transmitter

*Applies to Evaluation Kit with Transmitter:*

The transmitter is turned on for about 8ms and normal preamble (length used for normal data transmission) is sent. Then transmitter is turned off and waits for equal amount of time before another cycle.



**Figure 11: TX spectrum when transmitter is pulsed to transmit preamble**

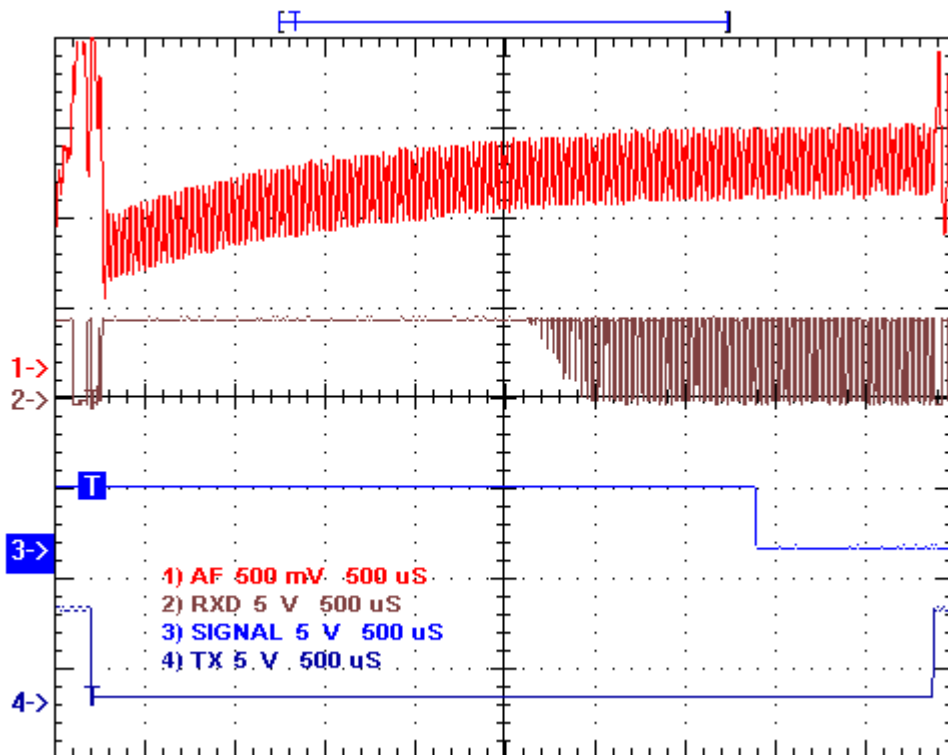

**Figure 12: pulsed preamble transmission and received preamble**

This mode can be used to test the power up time of transmitter and settling time of the receiver module when receiver is already powered up.

## Mode 6 – Echo

*Applies to Evaluation Kit with Receiver (and Transmitter):*

Receiver is turned on. Checks for preamble and if it finds a preamble, then it locks on to the data and receives the data packet. SIGNAL LED will be turned on if the preamble is detected. Then error check is carried out on the received data and if it passes, the OK LED is turned on and waits for a Transmit to Receive Change Over Delay period. Then it retransmits (echoes back) the packet to the transmitter.

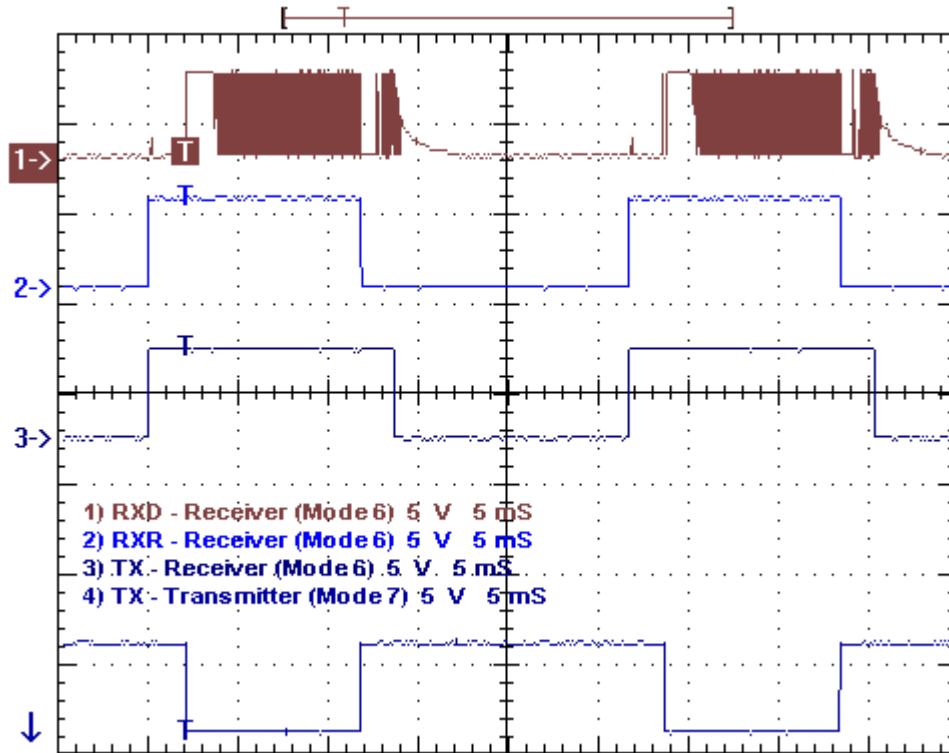

**Figure 13: receiver unit echoing back to transmitting unit on every valid packet**

The above oscilloscope screen capture shows RXR line pulled Low every time valid packet is received. Same RXR line activates the OK LED.

In the oscilloscope screen capture Figure 14, the receiving (mode 6) unit's echo did not reach the transmitting (mode 7) unit. Therefore, transmitting unit moves onto transmitting next packet after waiting for the time required to detect preamble of the echo packet.

**Note:** This may also happen if the Transmitter is removed from the receiving (mode 6) unit.

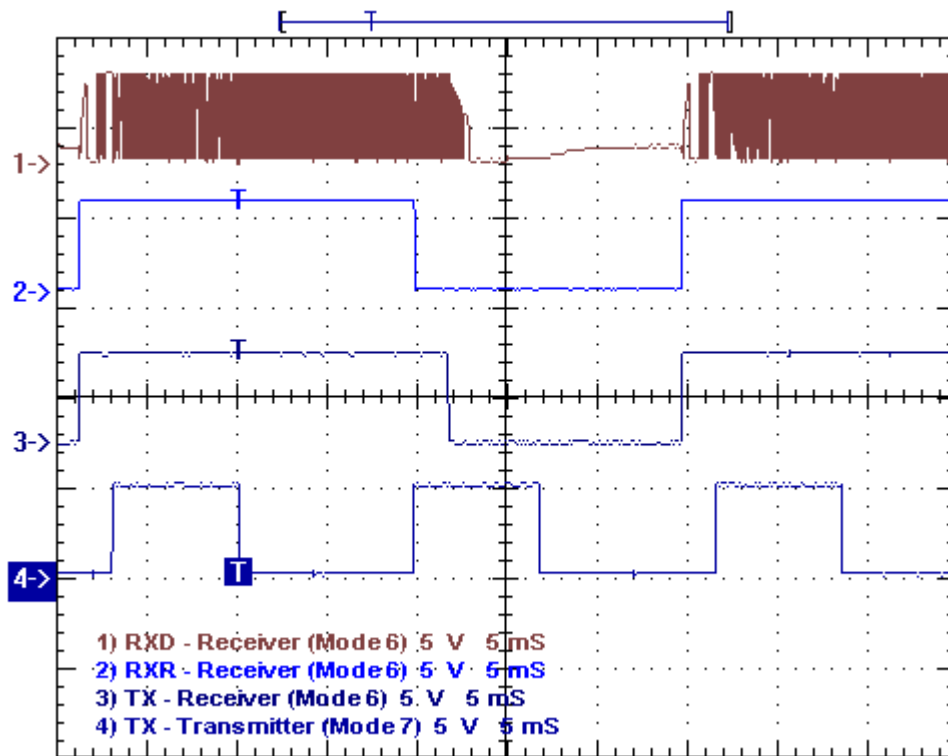

Figure 14: transmitting unit moves to next transmission because echo was not received

## Mode 7 – Radar

*Applies to Evaluation Kit with Transmitter (and receiver):*

Transmitter is turned on and sends a packet with **Universal Eval Kit XX** as data where XX will be a Packet Counter from 00 to 63. Then transmitter is turned off and receiver is turned on for 8ms. Checks for preamble and if it finds a preamble, then it locks on to the data and receives the packet. Then error check is carried out and if it passes, OK LED will be lit.

Nevertheless, it will continue the above process but the packet counter value will be increased with each transmission.

This mode can be used along with Mode 6 (Echo Mode) to function as a ‘Pin-Pong’ system. This provides a very effective method for Range Testing and Antenna Type Evaluation.

If one eval kit is set to Mode 6, then other eval kit can be set to Mode 7. By walking around the site where the final product based on the Radiometrix Modules are going to be used, the range and antenna type requirements, interference, etc could identified well in advance. The OK LED will be ON as long as the ‘Ping-Pong’ the units are within the radio range and the wireless link is error free.

OK LED will start to flicker on the Eval Kit set to mode 7, if some of the echoed packets are received with bit errors.

**Note:** Operating range of the modules will appear to be shorter due to the RF power loss in the common 50Ω microstrip.

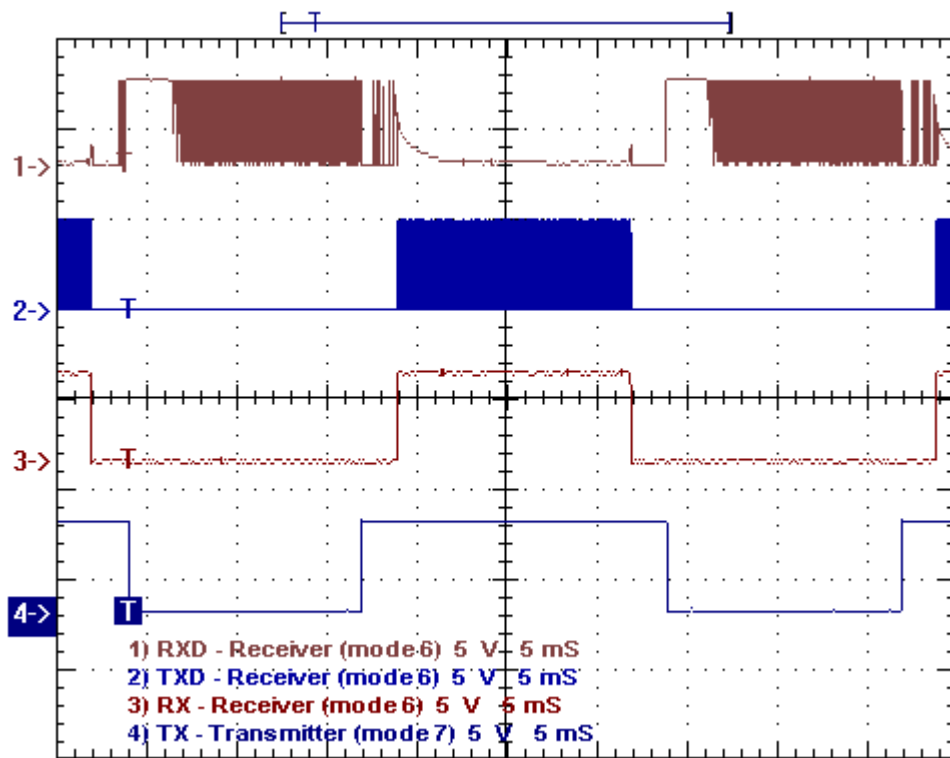

Figure 15: Receiver unit sampling (RXD output) received data bit but echo was received

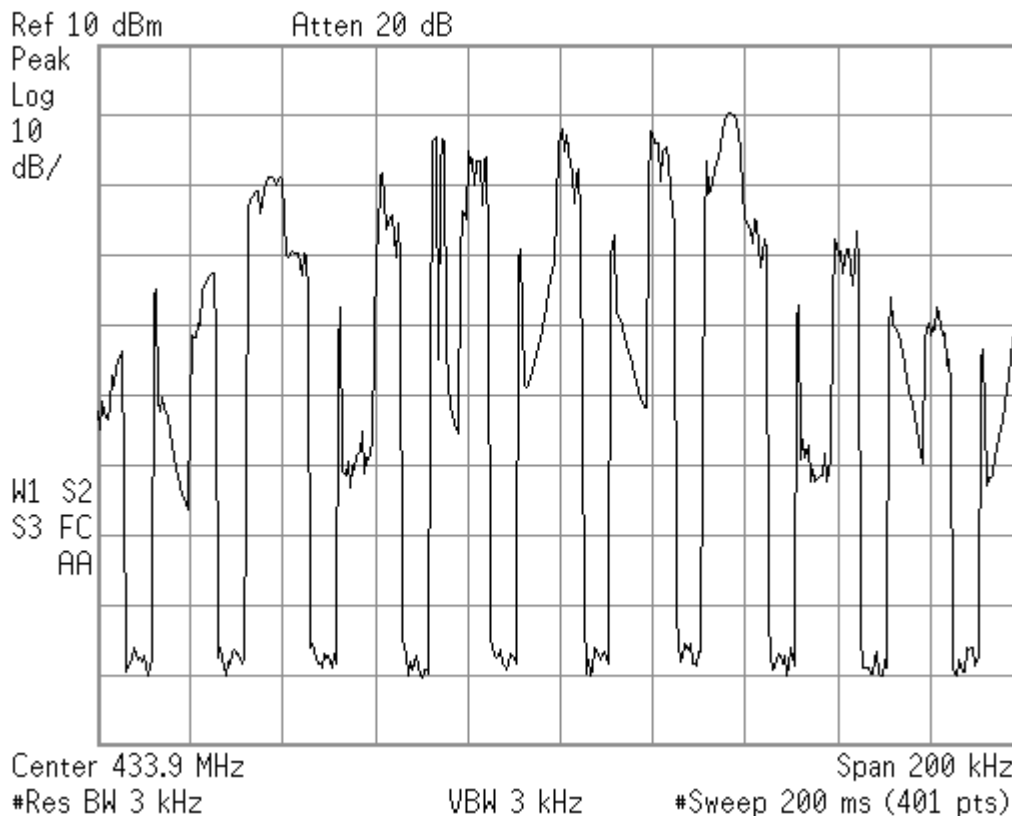

Figure 16: TX spectrum when transmitting radar mode ASCII data packet

## Mode 8 – Local Loop Test

Applies to Evaluation Kit with both Transmitter and Receiver:

This Eval RPC puts the transceiver or transmitter & receiver pair on same Eval kit into a local loop back (both TX & RX on), a test code is continuously sent and recovered. The SIGNAL LED will light to indicate a pass.

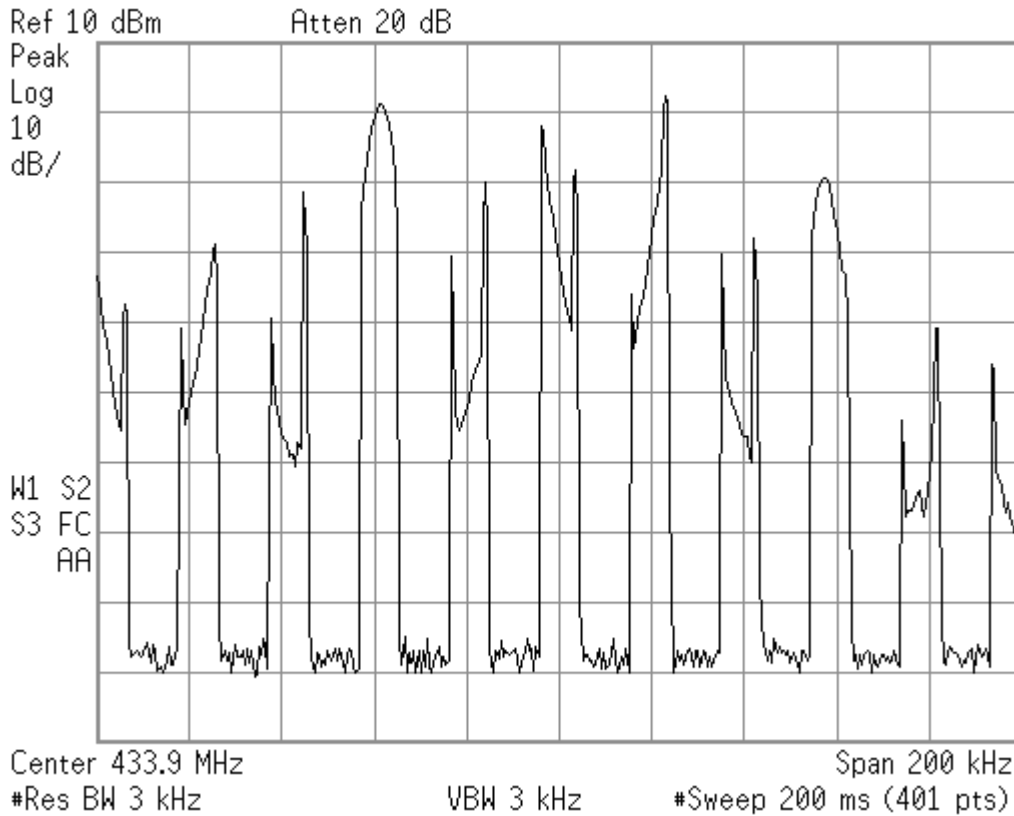

Figure 17: TX spectrum when transmitting unbalanced test code

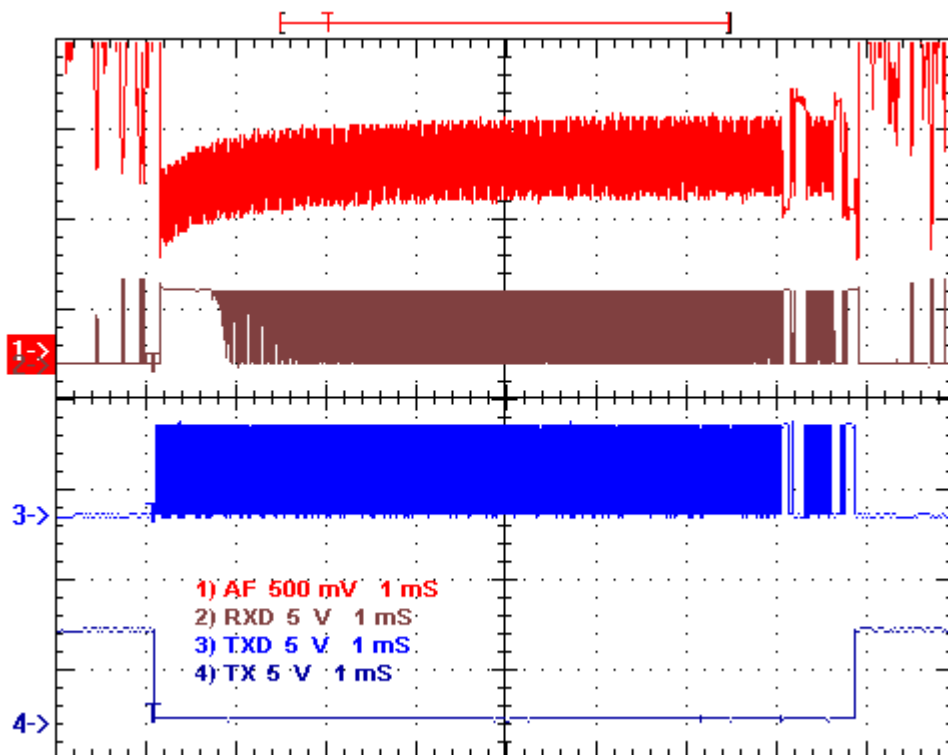
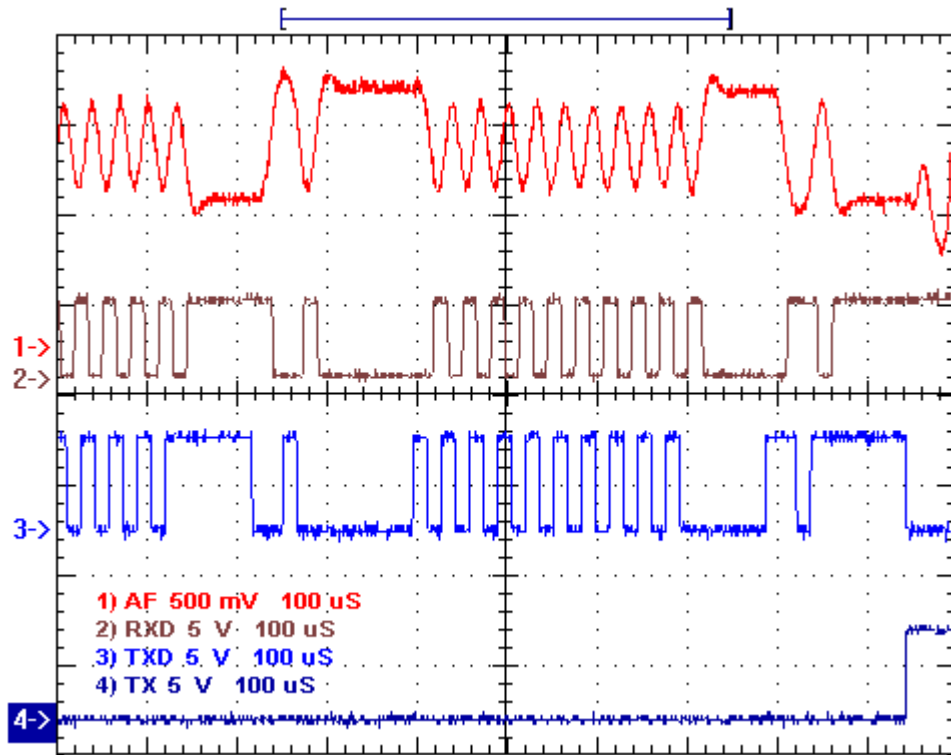

Figure 18: Transmitted and received unbalanced test code



**Figure 19: expanded view of the unbalanced test code**

The above waveform shows the test pattern used to evaluate receiver and its Adaptive Data Slicer.

### Mode F – Normal RPC Mode

Jumper Link (LK1) (below the 9V battery) should be removed and the RESET button should be depressed.

This will effectively put the Eval RPC into normal (non-diagnostic) mode. Therefore, any interface cable with Host Microcontroller or Parallel Port of a PC can be interfaced with the Eval Kit.

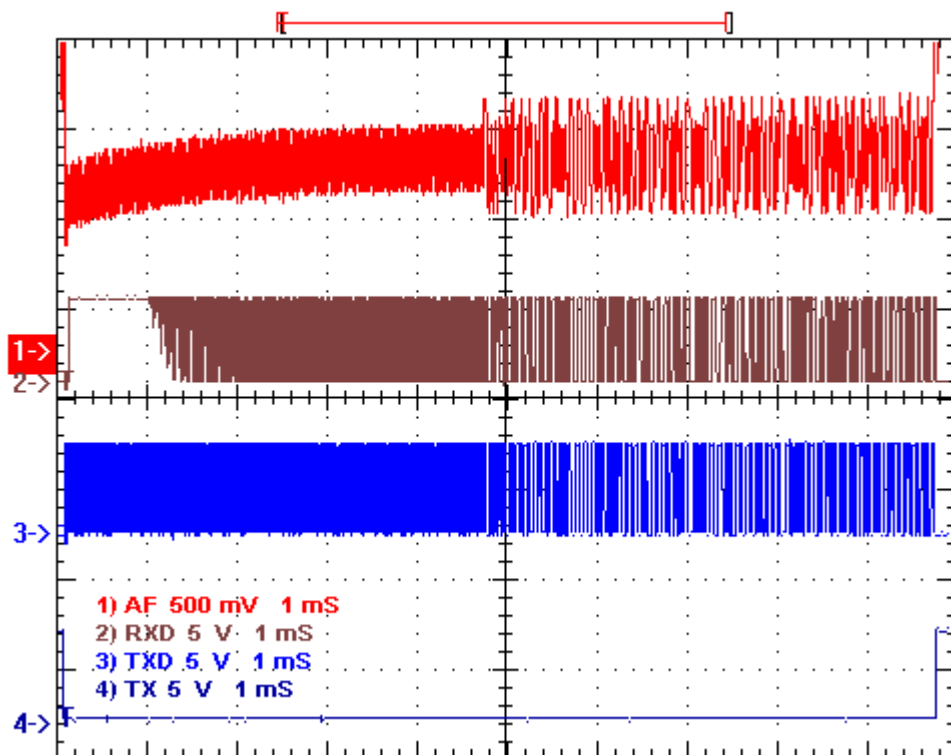

**Figure 20: Transmitted and received 27-byte (full length) data packet**

The trace below is a close up of the transition from preamble, synchronisation code and bytes count.

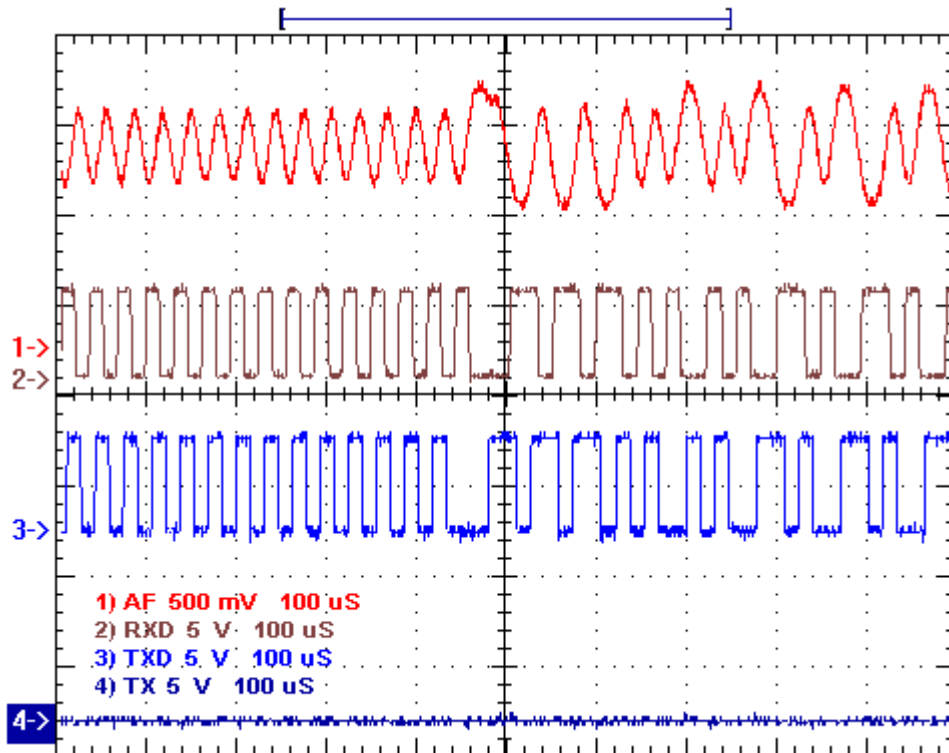

**Figure 21: Expanded view of the preamble to encoded data bit transition**

More details on the above data packet format are given on pages 17-19 of the SP2 data sheet.  
<http://www.radiometrix.co.uk/products/sp2.htm>

## PC Interface

Parallel Port Interface Adaptor can be used to interface the Universal Evaluation Kit to Parallel port using standard D25 parallel port extension cable (One to One connection with D25 plug connector on one end and D25 socket on other end)

RPC Development Kit software can be used to view/modify the Eval RPC EEPROM values. Data transmission can also be monitored using the same software.

This feature will help debug the host software routines in the design & development stage of a product.

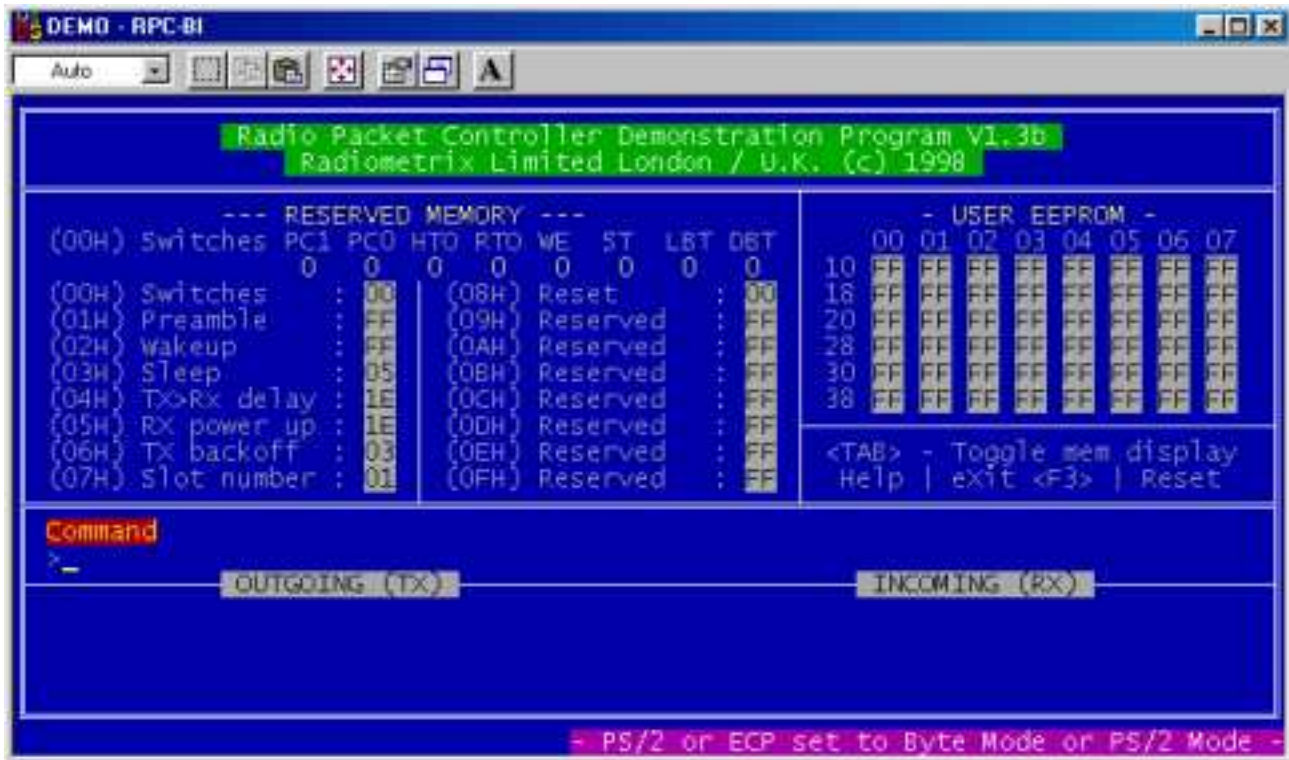

Figure 22: RPC Development Kit software showing the default EEPROM values of Eval RPC

**Note:** RPC development kit software runs on the MS-DOS operating system or Windows 95/98/98SE/ME. It will not run under NT4.0/XP/2000

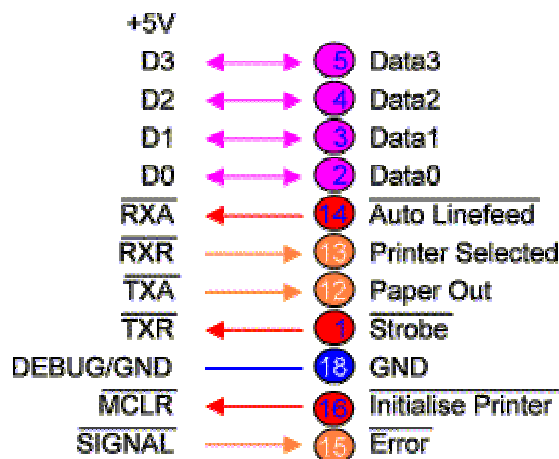

Figure 23: Eval RPC to Parallel port interface

## Analogue Signal

Even though the Radiometrix modules are specifically designed for data transmission, they can also be used for analogue transmission excluding signals which contain DC level or very low frequency components.

Analogue I/O board should be connected to the 10-pin header (J12) on top right hand corner of the Evaluation Kit. Jumper link on LK3 should also be removed to disconnect the TXD line from Eval RPC's data pin.

Analogue I/O contains

- 1) Analogue transmit signal amplifier
- 2) Buffered audio output for stereo headphone/speaker.

DC component in the analogue signal is removed via capacitor. A simple common emitter amplifier with negative feedback is used to amplify the small AC signal from few mV to few Volts. Signal level on TXD pin should be large enough to cause enough FM deviation on the RF carrier of the transmitter. Otherwise, the small demodulated AF output, under poor signal to noise ratio (S/N) conditions, will be indistinguishable or submerged in the noise. The AC signal is also biased at 1.25V, so that it is at half the transmit data voltage swing of 0-3V.

User can feed a function/waveform generator output through the Analogue In and receive the analogue output on the other kit to evaluate the performance of the module under various signal frequencies and amplitudes.

**Note:** a large signal on the Analogue input will saturate the amplifier and clipping may occur on the amplified signal.

Audio Frequency (AF) output can be monitored with a headphone or speaker to identify any noise or interference source in the environment. It can also be connected to Line In of a PC. User can walk around the building or field with the receiving kit while constantly listening to the Analogue Out. A crackling sound can be heard whenever user passes through a null spot or poor reception area. Any interference source can be clearly distinguished from expected analogue sound.

**Warning:** Headphone should be worn after switching on the transmitting kit and it should only be worn while the transmitter is on. It should be removed before switching off the transmitter. The output on the headphone will be too loud if the transmitter is switched off.

AF output will contain noise if the RF signal level drops. The unmuted noise level on the AF output has significantly higher amplitude compared to data signal level.

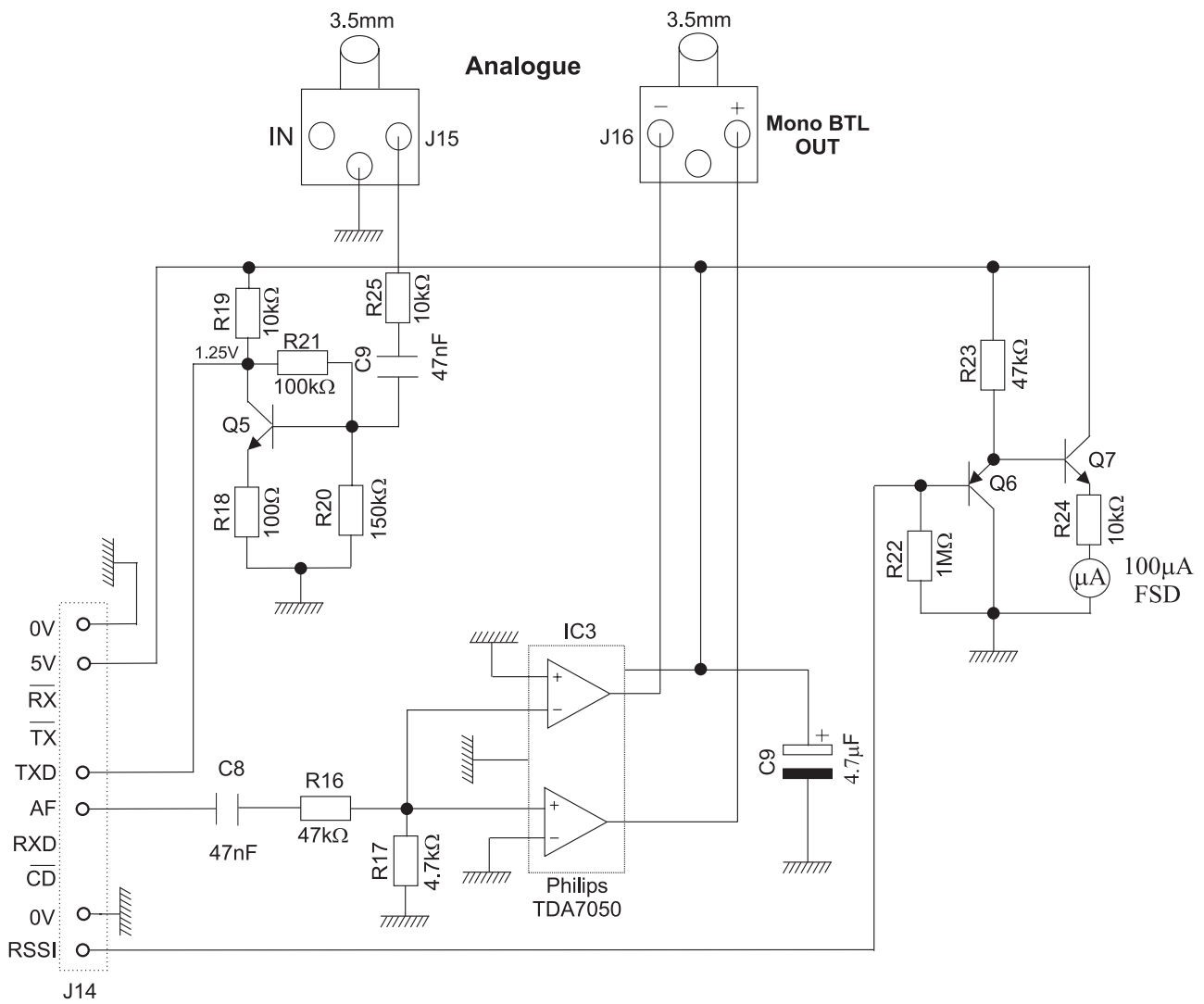

**Figure 24: Analogue I/O board circuit diagram**

R17 value can be increased to raise the audio volume.

R25 Value can be increased to prevent clipping if larger analogue signal is going to be applied on the input.

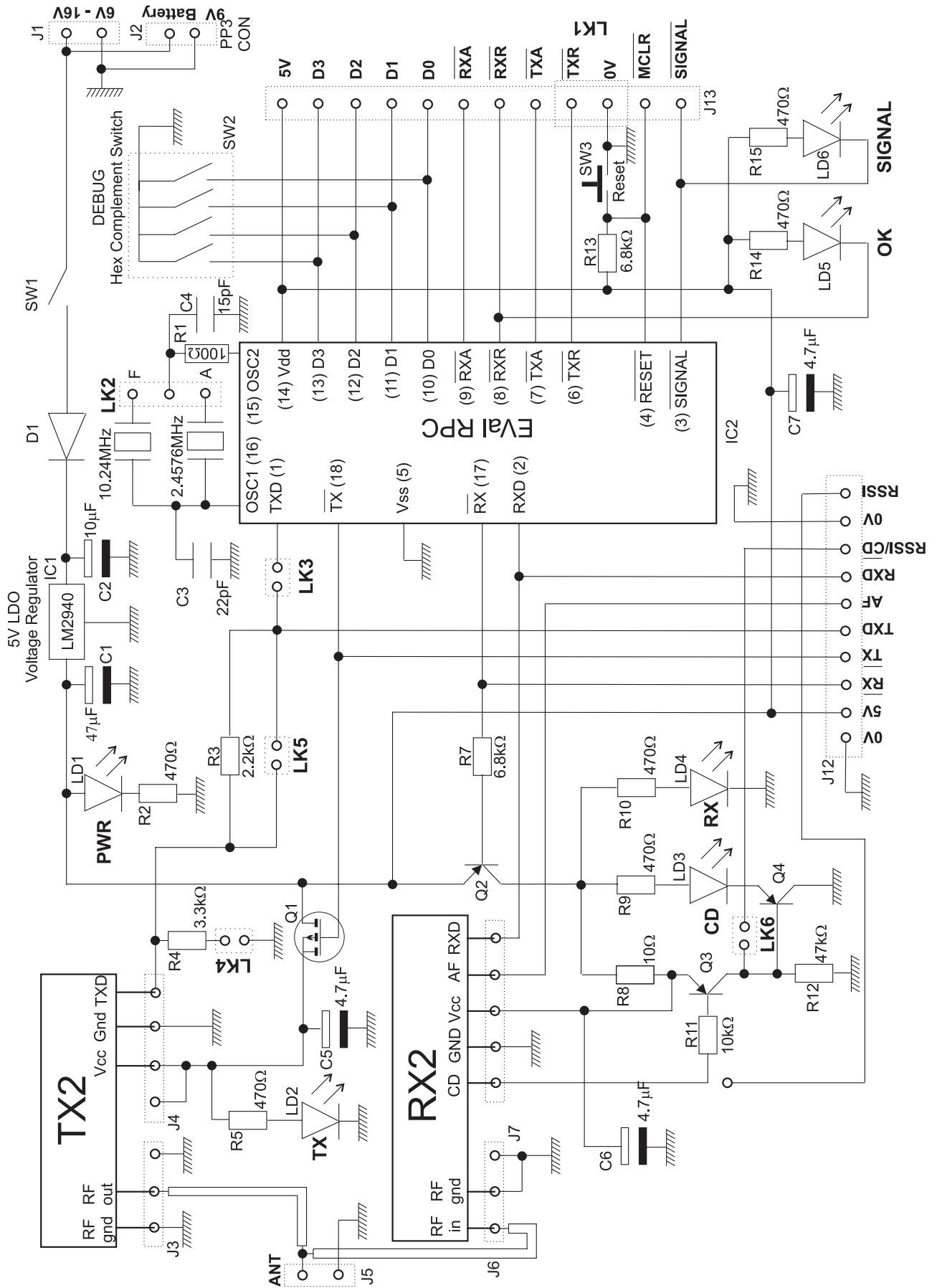

Figure 25: Evaluation of TX2 & RX2 using Universal Evaluation Kit

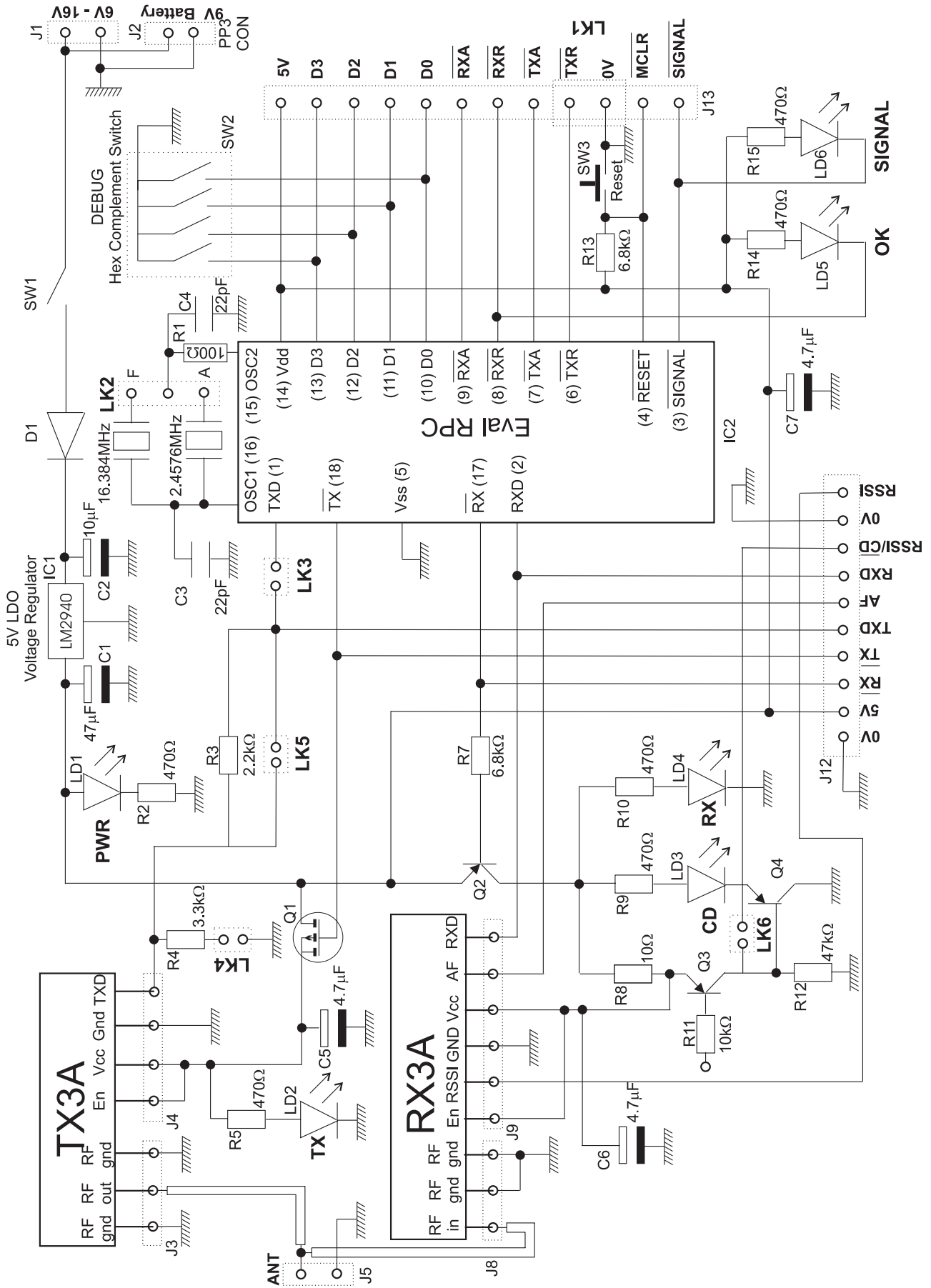

Figure 26: Evaluation of TX3A & RX3A using Universal Evaluation Kit





## Notes

# **Radiometrix Ltd**

**Hartcran House  
231 Kenton Lane  
Harrow, Middlesex  
HA3 8RP  
ENGLAND  
Tel: +44 (0) 20 8909 9595  
Fax: +44 (0) 20 8909 2233  
sales@radiometrix.com  
www.radiometrix.com**

## **Copyright notice**

*This product data sheet is the original work and copyrighted property of Radiometrix Ltd. Reproduction in whole or in part must give clear acknowledgement to the copyright owner.*

## **Limitation of liability**

*The information furnished by Radiometrix Ltd is believed to be accurate and reliable. Radiometrix Ltd reserves the right to make changes or improvements in the design, specification or manufacture of its subassembly products without notice. Radiometrix Ltd does not assume any liability arising from the application or use of any product or circuit described herein, nor for any infringements of patents or other rights of third parties which may result from the use of its products. This data sheet neither states nor implies warranty of any kind, including fitness for any particular application. These radio devices may be subject to radio interference and may not function as intended if interference is present. We do NOT recommend their use for life critical applications.*

*The Intrastat commodity code for all our modules is: 8542 6000*

## **R&TTE Directive**

*After 7 April 2001 the manufacturer can only place finished product on the market under the provisions of the R&TTE Directive. Equipment within the scope of the R&TTE Directive may demonstrate compliance to the essential requirements specified in Article 3 of the Directive, as appropriate to the particular equipment.*

*Further details are available on The Office of Communications (Ofcom) web site:  
<http://www.ofcom.org.uk/radiocomms/ifi/>*

*Information Requests  
Ofcom  
Riverside House  
2a Southwark Bridge Road  
London SE1 9HA  
Tel: +44 (0)845 456 3000 or 020 7981 3040  
Fax: +44 (0)20 7783 4033  
[information.requests@ofcom.org.uk](mailto:information.requests@ofcom.org.uk)*

*European Radiocommunications Office (ERO)  
Peblingehus  
Nansensgade 19  
DK 1366 Copenhagen  
Tel. +45 33896300  
Fax +45 33896330  
[ero@ero.dk](mailto:ero@ero.dk)  
[www.ero.dk](http://www.ero.dk)*

---