

Radiometrix

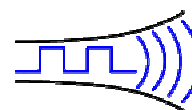

Hartcran House, 231 Kenton Lane, Harrow, HA3 8RP, England

Tel: +44 (0) 20 8909 9595, Fax: +44 (0) 20 8909 2233

Issue 2, 01 November 2004

TX2 & RX2

UHF FM Data Transmitter and Receiver Modules

The TX2 and RX2 data link modules are a miniature PCB mounting UHF radio transmitter and receiver pair which enable the simple implementation of a data link at upto 160 kbit/s at distances upto 75 metres in-building and 300 metres open ground.



left: TX2 transmitter

right: RX2 receiver

Features:

- ◆ CE certified by independent Notified Body
- ◆ Verified to comply with harmonised radio standard EN 300 220-3 by accredited Test Laboratory
- ◆ Verified to comply with harmonised EMC standard EN 301 489-3 by accredited Test Laboratory
- ◆ Data rates up to 160 kbps
- ◆ Usable range up to 300 m
- ◆ 433.92 MHz versions.
- ◆ Fully screened

Available for operation at 433.92 MHz in Europe (including UK), both modules combine full screening with extensive internal filtering to ensure EMC compliance by minimising spurious radiations and susceptibilities. The TX2 and RX2 modules will suit one-to-one and multi-node wireless links in applications including car and building security, EPOS and inventory tracking, remote industrial process monitoring and computer networking. Because of their small size and low power requirements, both modules are ideal for use in portable, battery-powered applications such as hand-held terminals.

Transmitter - TX2

- ◆ 2 stage SAW controlled, FM modulated at up to 160 kbps
- ◆ Operation from 2.2V to 6V
- ◆ +9dBm on 433.92MHz
- ◆ High efficiency, >15%, DC RF
- ◆ Improved frequency and deviation accuracy
- ◆ 2nd harmonic, < -60dBc

Receiver - RX2

- ◆ Double conversion FM superhet
- ◆ SAW front end filter, image rejection 50dB
- ◆ Supply 3.0V to 6.0V @ 13mA
- ◆ -96 dBm sensitivity @ 1ppm BER with 160kbps version
- ◆ -100 dBm sensitivity @ 1ppm BER with 40kbps-version
- ◆ -107 dBm sensitivity @ 1ppm BER with 14kbps-version
- ◆ LO leakage, < -60 dBm

Functional description:

The TX2 transmitter module is a two stage, SAW controlled FM transmitter operating between 2V and 6V and is available in 433.92MHz. The TX2 module is type approved to EN 300 220-3 for European use and delivers nominally +9dBm from a 5V supply at 12mA. The module measures 32 x 12 x 3.8 mm.

The RX2 module is a double conversion FM superhet receiver capable of handling data rates of up to 160kbps. The SIL style RX2 receiver measures 48 x 17.5 x 4.5 mm. It will operate from a supply of 3-6V and draws 14mA when receiving. A fast-acting carrier detect and a power-up enable time of less than 1ms. This allows effective duty cycle power saving and a -107 dBm sensitivity. This combined with a SAW front-end filter results in an excellent RF performance and EMC conformance.

TX2 transmitter:

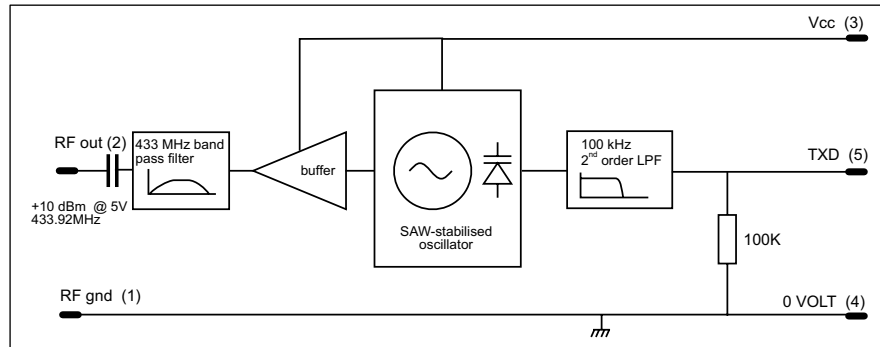

Fig. 1: TX2 block diagram

Pin description:

RF GND (pin 1)

RF ground pin, internally connected to the module screen and pin 4 (0V). This pin should be connected to the RF return path (e.g. coax braid, main PCB ground plane etc.)

RF out (pin 2)

50Ω RF output to the antenna, it is DC isolated internally. (see antenna section for suggested antenna/feeds).

Vcc (pin 3)

+ve supply pin. The module will generate RF when the Vcc supply is present. Maximum ripple content 0.1V_{P-P}. A 100nF de-coupling ceramic capacitor is suggested.

0V (pin 4)

Supply ground connection, connected to pin 1 and screen.

TXD (pin 5)

This DC coupled modulation input will accept either serial digital data (0V to Vcc levels) or high level linear signals. Input impedance is 100kΩ.

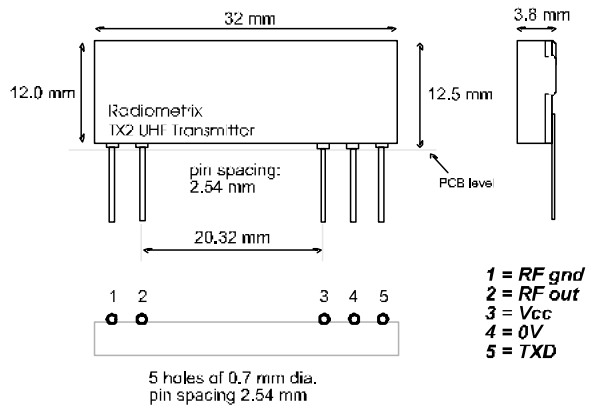

Fig.2: physical dimensions

RX2 receiver:

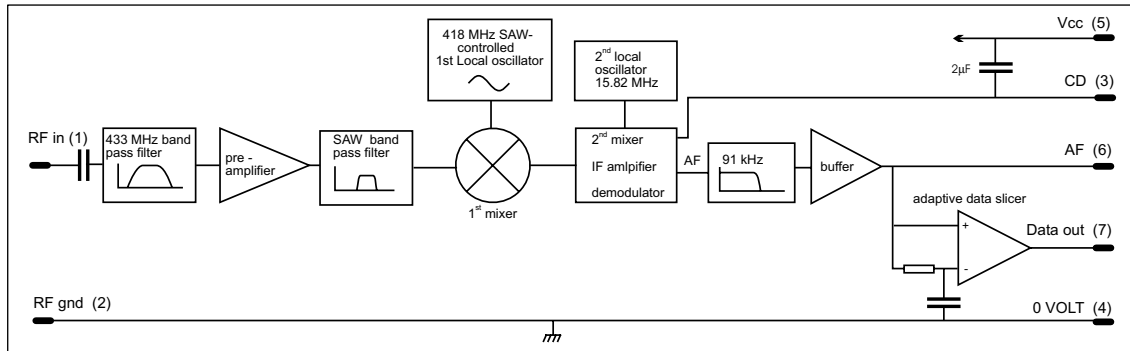

Fig. 3: RX2 block diagram

Pin description

RF in (pin 1)

50Ω RF input from the antenna, it is DC isolate internally. (see antenna section for suggested antenna/feeds).

RF GND (pin 2)

RF ground pin, internally connected to the module screen and pin 4 (0V). This pin should be connected to the RF return path (e.g. coax braid, main PCB ground plane etc.)

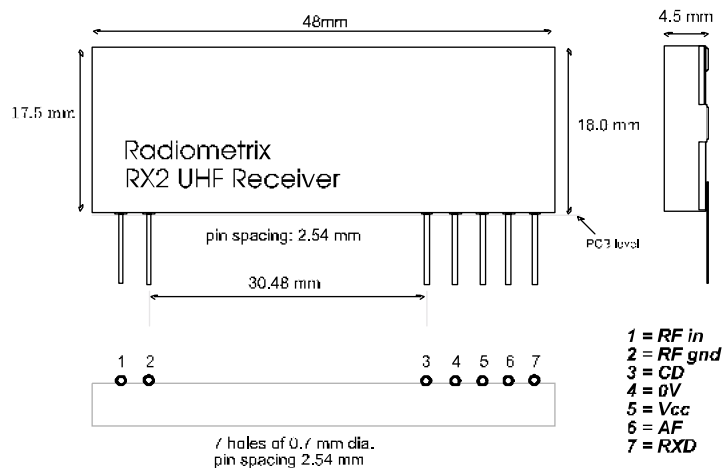

Fig. 4: physical dimensions

CD (pin 3)

The Carrier Detect may be used to drive an external PNP transistor to obtain a logic level carrier detect signal, see test circuit. If not required it should be connected to pin 5 (Vcc).

0 Volt (pin 4)

Supply ground connection, connected to pin 1 and screen.

Vcc (pin 5)

+ve supply pin. +3.0V to +6.0V @ <17mA . The supply must be clean < 2mV_{P-P} ripple. A 10µF decoupling capacitor and 10Ω series resistor is recommended if a clean supply is not available.

AF (pin 6)

This is a buffered and filtered analogue output from the FM demodulator. It has a standing DC bias of 1.2V and 400mV_{P-P} base band signal. It is useful as a test point or to drive linear decoders. Load impedance should be > 2kΩ and < 100pF.

RXD (pin 7)

This digital output from the internal data slicer is a squared version of the signal on pin 6 (AF). It may be used to drive external decoders. The data is true data, i.e. as fed to the transmitter. Load impedance should be > 1kΩ and < 1nF

Survival Maximums:

Operating temperature: -10°C to +55°C
 Storage temperature: -40°C to +100°C

TX2, all variants

Vcc (pin 3) -0.1V to +10.0V
 Data input (pin 5) -0.1V to +10.0V
 RF out (pin 2) ±50V @ < 10MHz , +20dBm @ > 10MHz

RX2, all variants

Vcc (pin 5) -0.1V to +10.0V
 Data, CD & AF (pin 7,3,6) -0.1V to + Vcc V
 RF input (pin 1) ±50V @ < 10MHz , +13dBm @ > 10MHz

note: Operation of the TX2 above 6V may cause the module to exceed the licensed power level.

Electrical Performance: TX2 transmitter

	pin	min.	typ.	max.	units	notes
DC LEVELS						
supply voltage	3	2.2	3.0	4.0	V	-3V version
supply voltage	3	4.0	5.0	6.0	V	-5V version
CURRENT & RF POWER						
<i>TX2-433-3V</i>						
supply current @ Vcc = 3V	3	4	6	10	mA	
RF power @ Vcc = 3V	2	0	+4	+6	dBm	1
<i>TX2-433-5V</i>						
supply current @ Vcc = 5V	3	7	10	14	mA	
RF power @ Vcc = 5V	2	+6	+9	+12	dBm	1
RF						
2 nd harmonic	2	-	-65	-54	dBc	1
harmonics @ > 1GHz	2	-	-50	-40	dBc	1
initial frequency accuracy	-	-30	0	+30	kHz	
overall frequency accuracy	-	-70	-	+70	kHz	
FM deviation (+/-)	-	20	25	30	kHz	
modulation bandwidth @ -3dB	-	DC	-	20	kHz	
modulation bandwidth @ -3dB	-	DC	-	100	kHz	2
modulation distortion (THD)	-	-	5	10	%	
power up time to full RF	-	-	-	100	µs	

note: 1. Measured into a 50Ω load.
 2. For 160kbps version

Electrical Performance: RX2 Receiver

Unless otherwise noted:

Figures apply to 5V versions unless noted otherwise

V_{cc} = 5.0V, temperature 20°C unless noted otherwise

	pin	min.	typ.	Max.	units	notes
DC LEVELS						
supply voltage, V _{cc} standard	5	4.0	5.0	6.0	V	
supply voltage, V _{cc} , 3V version	5	3.3	3.5	4.0	V	
supply current	5	11	13	17	mA	
supply ripple	5	-	-	2	mV _{P-P}	1
data output high, 100µA source	7	-	V _{cc} -0.6	-	V	
data output low, 100µA sink	7	-	0.4	-	V	
load capacitance on AF / Data	6,7	-	-	100	pF	
RF						
RF sensitivity for 10dB (S+N)/N	1,6	-107	-113	-	dBm	14kbps version
RF sensitivity for 10dB (S+N)/N	1,6	-100	-107	-	dBm	40kbps version
RF sensitivity for 10dB (S+N)/N	1,6	-	-96	-	dBm	160kbps version
RF sensitivity for 1ppm BER	1,6	-100	-107	-	dBm	14kbps version
RF sensitivity for 1ppm BER	1,6	-93	-100	-	dBm	40kbps version
RF sensitivity for 1ppm BER	1,6	-	-90	-	dBm	160kbps version
CD threshold	1,3	-97	-107	-	dBm	14kbps version
CD threshold	1,3	-90	-100	-	dBm	40kbps version
CD threshold	1,3	-	-104	-	dBm	160kbps version
IF band width	-	-	250	-	kHz	
initial frequency accuracy	1	-30	0	+30	kHz	
E.M.C.						
image rejection (2*F _{IF})	1	-	-50	-	dB	2
spurious responses upto 1GHz	1	-	-70	-	dB	2
LO leakage, conducted	1	-	-65	-	dBm	
LO leakage, radiated	-	-	-70	-	dBm	
AF BASE BAND						
baseband bandwidth @ -3dB	6	0.006	-	7	kHz	14kbps version
baseband bandwidth @ -3dB	6	0.060	-	20	kHz	40kbps version
baseband bandwidth @ -3dB	6	0.250	-	91	kHz	160kbps version
AF level	6	-	450	-	mV _{P-P}	
DC offset on AF	6	0.8	1.2	1.6	V	
distortion on recovered AF	6	-	0.5	1	%	
ultimate (S+N)/N	6	35	45	-	dB	
ultimate (S+N)/N	6	-	28	-	dB	160kbps version
DYNAMIC TIMING						
Power up with signal present						
power up to valid CD, T _{PU-CD}	-	-	1	-	ms	
power up to stable data, T _{PU-DAT}	-	-	20	-	ms	14kbps version
power up to stable data, T _{PU-DAT}	-	-	5	-	ms	40kbps version
power up to stable data, T _{PU-DAT}	-	-	3	-	ms	160kbps version
power up to stable AF, T _{PU-AF}	-	-	0.6	-	ms	160kbps version
power up to valid CD, T _{PU-CD}	-	-	0.7	-	ms	160kbps version

	pin	min.	typ.	Max.	units	notes
Signal applied with supply on						
signal to valid CD, T_{SIG-CD}	-	-	0.5	-	ms	
signal to stable data, $T_{SIG-DAT}$	-	-	15	-	ms	14kbps version
signal to stable data, $T_{SIG-DAT}$	-	-	3	-	ms	40kbps version
signal to stable data, $T_{SIG-DAT}$	-	-	0.75	-	ms	160kbps version
signal to stable AF, T_{SIG-AF}	-	-	0.1	-	ms	160kbps version
signal to valid CD, T_{SIG-CD}	-	-	0.2	-	ms	160kbps version
time between data transitions	7	0.07	-	15	ms	4, 14kbps version
time between data transitions	7	0.025	-	1.5	ms	4, 40kbps version
time between data transitions	7	0.00625	-	0.5	ms	4, 160kbps version
mark:space ratio	-	20	50	80	%	3

notes:

1. For 6dB (S+N)/N degradation on wanted -100dBm signal
2. Receiver spurious responses are at $F_{RF} \pm (n \times 15.92\text{MHz})$, $n=1,2,3$ etc.
3. Average over 30ms (14kbps), 3ms (40kbps), 1ms (160kbs) at maximum bit rate.
4. Values for 50:50 mark to space (i.e. square wave)

Module test circuits

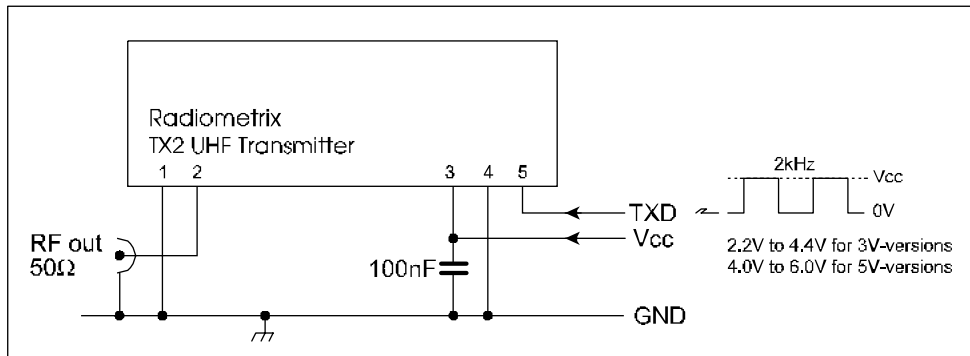

Fig.5: TX2 test circuit

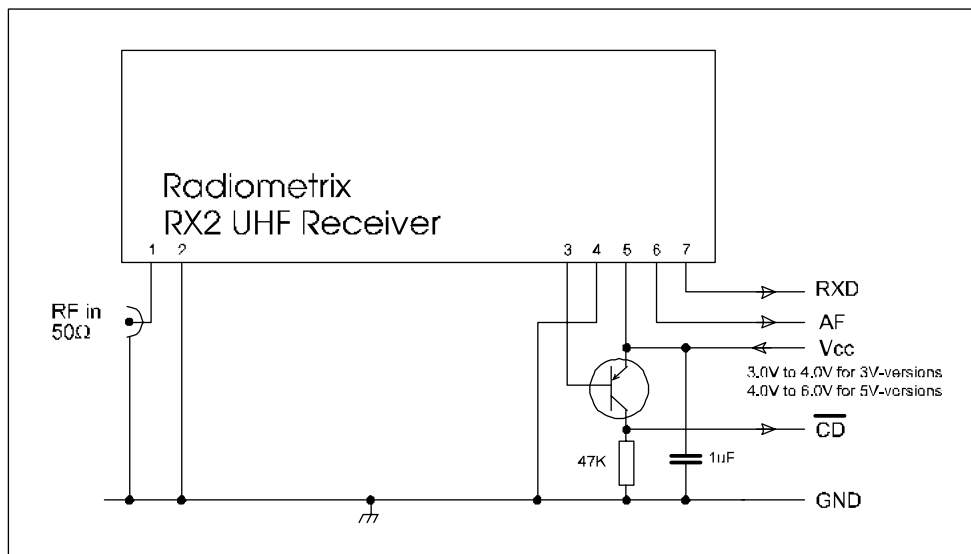

Fig.6: RX2 test circuit

* The PNP transistor (e.g. BC558B) enables a CMOS compatible Carrier Detect signal to be derived from pin 3. If no CD signal required pin 3 should be connected directly to pin 5 (Vcc).

Module mounting considerations

The modules may be mounted horizontally or vertically on an area of ground plane preferably close to the antenna to minimise feed length. The receiver and it's antenna should be kept away from sources of interference (micro's, SMPS etc.). The modules may be potted if required in a viscous compound which can not enter the screen can..

Warning: Do NOT wash the modules. They are not hermetically sealed.

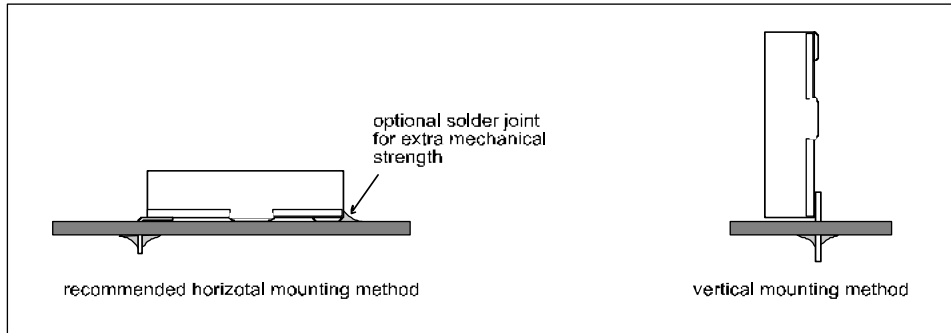

Fig. 7: module mounting options

Antenna requirements

Three types of integral antenna are recommended and approved for use with the module:

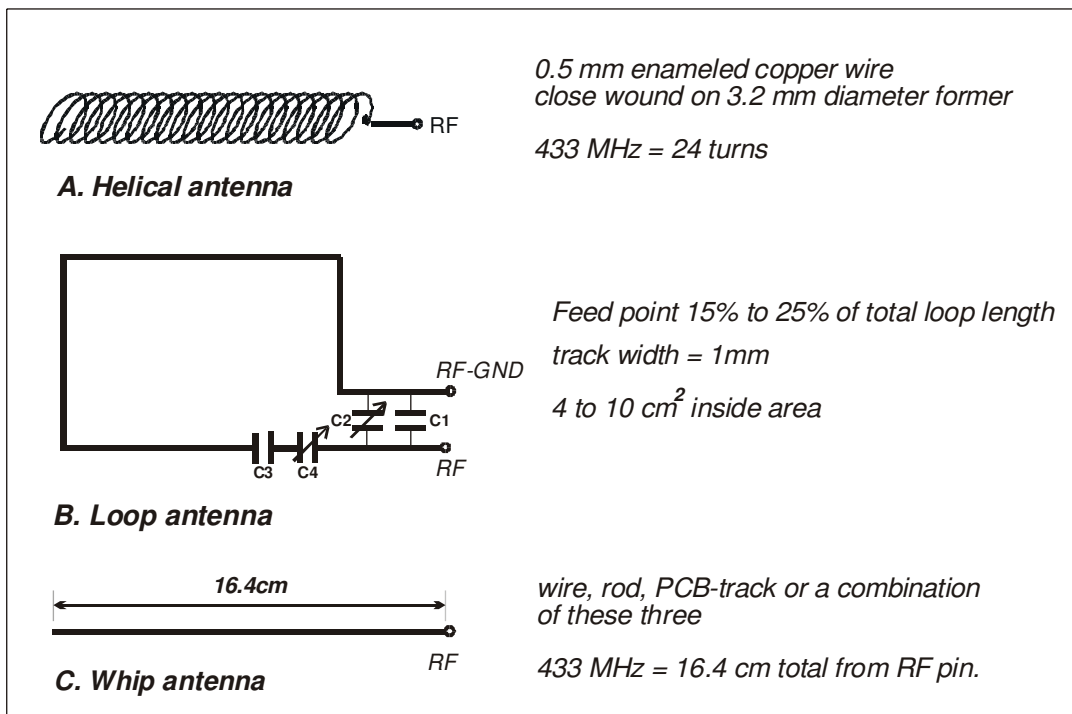

Fig.8: Antenna

	A	B	C
	<i>helical</i>	<i>loop</i>	<i>whip</i>
Ultimate performance	**	*	***
Easy of design set-up	**	*	***
Size	***	**	*
Immunity proximity effects	**	***	*
Range open ground to similar antenna (for TX2-433-14-5V & RX2-433-14-5V)	200m	100m	300m

Antenna selection chart

- A) *Helical* Wire coil, connected directly to pin 2, open circuit at other end. This antenna is very efficient given it's small size (20mm x 4mm dia.). The helical is a high Q antenna, trim the wire length or expand the coil for optimum results. The helical de-tunes badly with proximity to other conductive objects.
- B) *Loop* A loop of PCB track tuned by a fixed or variable capacitor to ground at the 'hot' end and fed from pin 2 at a point 20% from the ground end. Loops have high immunity to proximity de-tuning.
- C) *Whip* This is a wire, rod, PCB track or combination connected directly to pin 2 of the module. Optimum total length is 15.5cm (1/4 wave @ 433MHz). Keep the open circuit (hot) end well away from metal components to prevent serious de-tuning. Whips are ground plane sensitive and will benefit from internal 1/4 wave earthed radial(s) if the product is small and plastic cased

The antenna choice and position directly controls the system range. Keep it clear of other metal in the system, particularly the 'hot' end. The best position by far, is sticking out the top of the product. This is often not desirable for practical/ergonomic reasons thus a compromise may need to be reached. If an internal antenna must be used try to keep it away from other metal components, particularly large ones like transformers, batteries and PCB tracks/earth plane. The space around the antenna is as important as the antenna itself

Duty Cycle requirements

The duty cycle is defined as the ratio, expressed as a percentage, of the maximum transmitter "on" time on one or more carrier frequencies, relative to a one hour period. Where an acknowledgement message is required, the additional transmitter "on" time shall be included.

There is a 10% duty cycle restriction on 433.050-434.790 MHz band in most of the EU member states.

The TX2-433 is a RF module intended to be incorporated into a wide variety of applications and finished products, Radiometrix has no control over the end use of the TX2-433. The harmonised band 433.050 to 434.790 MHz as detailed in Annex 1 Band E of CEPT/ERC Recommendation 70-03 (which can be downloaded at <http://www.ero.dk/scripts/docmanag98/dm.dll/QueryDoc?Cat=Recommendation>) has list of countries where Duty Cycle restriction apply.

Module users should, therefore, ensure that they comply with the stated Duty Cycle requirements of the version of CEPT/ERC Recommendation 70-03 in place at the time of incorporation of the TX2-433 into their product. It should be noted that the stated Duty Cycle must not be exceeded otherwise any approval granted for the TX2-433 will be invalidated.

Variants and Ordering information

The TX2 transmitter and RX2 receiver are manufactured in several variants

Supply voltage 5V (4V to 6V TX2 & RX2)
3V (3.3V to 4V for RX2, 2.2V to 4V for TX2)

RX data rate: Slower version, 7kHz baseband BW, data rate up to 14kbps
Faster version, 20kHz baseband BW, data rate up to 40kbps
Very fast version 91kHz baseband BW, data rate up to 160kbps

TX data rate Faster version, 20kHz baseband BW, data rate up to 40kbps
Very fast version, 100kHz baseband BW, data rate up to 160kbps

The following are standard:

TX2-433-40-5V:	433.92 MHz , 5V TX , 10mW
TX2-433-160-5V:	433.92 MHz , 5V TX , 10mW
RX2-433-14-5V:	433.92 MHz , 5V RX , 14kbps
RX2-433-40-5V:	433.92 MHz , 5V RX , 40kbps
RX2-433-160-5V	433.92 MHz , 5V RX , 160kbps

3V versions of the above are available and should be ordered with a -3V suffix on the part number.
(e.g. RX2-433-14-3V is set-up for 3.3V to 4V operation)



Radio Frequency Investigation Ltd

Ewhurst Park, Ramsdell, Basingstoke,
Hampshire RG26 5RQ

Switchboard Tel: +44 (0) 1256 851193

Sales Tel: +44 (0) 1256 855400

Fax: +44 (0) 1256 851192

E-mail: sales@rfi-wireless.com

Web Site: www.rfi-wireless.com

CERTIFICATE OF CONFORMANCE FROM RADIO FREQUENCY INVESTIGATION LTD.

Test Of: Radiometrix
TX2-433 Transmitter

To: EN 300 220-1 V1.3.1 (2000-09)
according to the requirements of EN 300 220-3 V1.1.1 (2000-09),
Harmonised EN covering essential requirements
under Article 3.2 of the R&TTE Directive

Certificate of Conformance Serial No:
RFI/MPTB1/SC42346B

This is to certify that a sample of the equipment defined above has been tested by Radio Frequency Investigation Ltd. (Basingstoke) to the above standard as detailed in RFI report number RFI/MPTB1/RP42346B. In the configuration tested the equipment was compliant with the standard or parts of the standard applied to the sample.	
For full details please refer to document RFI/MPTB1/RP42346B	
Tested By: <i>N. J. Deale</i>	Approved Signatory: <i>A. J. ...</i>
Certificate Copy No: 01	Test Item Receipt Date: 08 October 2001
Issue Date: 17 October 2001	Test Date: 08 October 2001
Issued to: Mr G. Sharples Managing Director Radiometrix Ltd Hartcran House Gibbs Couch Carpenders Park Watford Hertfordshire WD1 5EZ	Deviations from tested standard: None.
This certificate may be reproduced in full. Partial reproduction may only be made with the written consent of Radio Frequency Investigation Ltd. This certificate applies only to the sample(s) tested.	

A CATALYST IN WIRELESS DEVELOPMENT

Registered in England, No. 211 7901 - Registered Office: Ewhurst Park, Ramsdell, Basingstoke, Hampshire RG26 5RQ





Radio Frequency Investigation Ltd

Ewhurst Park, Ramsdell, Basingstoke,
Hampshire RG26 5RQ

Switchboard Tel: +44 (0) 1256 851193

Sales Tel: +44 (0) 1256 855400

Fax: +44 (0) 1256 851192

E-mail: sales@rfl-wireless.com

Web Site: www.rfl-wireless.com

CERTIFICATE OF CONFORMANCE FROM RADIO FREQUENCY INVESTIGATION LTD.

Test Of: Radiometrix Ltd.
TX2-433

To: EN 301 489-1 V1.2.1 (2000-08)
according to the specific conditions
detailed in EN 301 489-3 V1.2.1 (2000-08)
(requested parts only)

Certificate of Conformance Serial No:
RFI/EMCB1/TC42346ETF01A

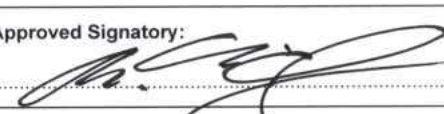
This is to certify that a sample of the equipment defined above has been tested by Radio Frequency Investigation Ltd. (Basingstoke) to the above standard as detailed in RFI report number RFI/EMCB1/TS42346ETF01A. In the configuration tested the equipment was compliant with the standard or parts of the standard applied to the sample.	
For full details please refer to document RFI/EMCB1/TS42346ETF01A	
Tested By: 	Approved Signatory: 
Certificate Copy No:	Test Item Receipt Date: 02 July 2001
Issue Date: 25 July 2001	Test Date: 02 July 2001
Issued to: Radiometrix Ltd Hartcran House Gibbs Couch Carpenders Park Watford WD1 5EZ Hertfordshire	Deviations from tested standard: None.
This certificate may be reproduced in full. Partial reproduction may only be made with the written consent of Radio Frequency Investigation Ltd. This certificate applies only to the sample(s) tested.	

A CATALYST IN WIRELESS DEVELOPMENT

Registered in England, No. 211 7901. Registered Office: Ewhurst Park, Ramsdell, Basingstoke, Hampshire RG26 5RQ





Radio Frequency Investigation Ltd

Ewhurst Park, Ramsdell, Basingstoke,
Hampshire RG26 5RQ

Switchboard Tel: +44 (0) 1256 851193

Sales Tel: +44 (0) 1256 855400

Fax: +44 (0) 1256 851192

E-mail: sales@rfi-wireless.com

Web Site: www.rfi-wireless.com

CERTIFICATE OF CONFORMANCE FROM RADIO FREQUENCY INVESTIGATION LTD.

Test Of: Radiometrix Ltd.
RX2-433

To: EN 301 489-1 V1.2.1 (2000-08)
according to the specific conditions
detailed in EN 301 489-3 V1.2.1 (2000-08)
(requested parts only)

Certificate of Conformance Serial No:
RFI/EMCB1/TC42137ETF10A

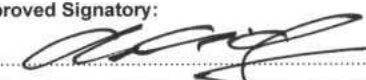
<p>This is to certify that a sample of the equipment defined above has been tested by Radio Frequency Investigation Ltd. (Basingstoke) to the above standard as detailed in RFI report number RFI/EMCB1/TS42137ETF10A . In the configuration tested the equipment was compliant with the standard or parts of the standard applied to the sample.</p> <p>For full details please refer to document RFI/EMCB1/TS42137ETF10A</p>	
<p>Tested By:</p> 	<p>Approved Signatory:</p> 
<p>Certificate Copy No:</p>	<p>Test Item Receipt Date: 11 June 2001</p>
<p>Issue Date: 25 July 2001</p>	<p>Test Date: 14 June 2001</p>
<p>Issued to: Radiometrix Ltd Hartcran House Gibbs Couch Carpenders Park Watford WD1 5EZ Hertfordshire</p>	<p>Deviations from tested standard: None.</p>
<p>This certificate may be reproduced in full. Partial reproduction may only be made with the written consent of Radio Frequency Investigation Ltd. This certificate applies only to the sample(s) tested.</p>	

A CATALYST IN WIRELESS DEVELOPMENT

Registered in England, No. 211 7901. Registered Office: Ewhurst Park, Ramsdell, Basingstoke, Hampshire RG26 5RQ



CE Certificate of TX2 and its variants



Radio Frequency Investigation Ltd

NOTIFIED BODY OPINION RFI/NBCB1/RP42627JD06

Applicants Details

Applicant's Company Name: Radiometrix Ltd
Address: Hartcran House, Gibbs Couch, Carpenters Park, Watford, Herts.
WD1 5EZ
Contact Name: Mr S. Paramanathan

Manufacturers Details

Manufacturer's Company Name: Radiometrix Ltd
Address: Hartcran House, Gibbs Couch, Carpenters Park, Watford, Herts.
WD1 5EZ
Contact Name: Mr S. Paramanathan

Product Details

Product Name: TX2-433
Model Number(s): TX2-433-40-5V
TX2-433-40-3V
TX2-433-160-5V
TX2-433-160-3V
TCF Reference Number: RM/TX2/DTD
Standard(s): I ETS 300 220: 1993
Description: UHF FM Data Transmitter Module

In the opinion of RFI, the Technical Construction File demonstrates that the Apparatus to which it relates conforms to the essential requirements of Article 3.2 of Council Directive 1999/5/EC on radio equipment and telecommunications terminal equipment and the mutual recognition of their conformity.

Authorised Signatory:

A handwritten signature in black ink, appearing to read 'N Cobb', is written over a horizontal line.

Mr N Cobb

16-10-06

Date



Company Seal

Notified Body Number - 0889

Radio Frequency Investigation Ltd, Ewhurst Park, Ramsdell, Basingstoke, Hampshire RG26 5RQ, ENGLAND
Tel: +44 (0) 1256 851193 Fax: +44 (0) 1256 851192 E-mail: sales@rfi.co.uk
Registered In England, No. 211 7901

CE Certificate of RX2 and its variants



Radio Frequency Investigation Ltd

NOTIFIED BODY OPINION RFI/NBCB1/42627JD02

Applicants Details

Applicant's Company Name: Radiometrix Ltd
Address: Hartcran House, Gibbs Couch, Carpenters Park, Watford, Herts.,
WD1 5EZ
Contact Name: Mr S. Paramananthan

Manufacturers Details

Manufacturer's Company Name: Radiometrix Ltd
Address: Hartcran House, Gibbs Couch, Carpenters Park, Watford, Herts.,
WD1 5EZ
Contact Name: Mr S. Paramananthan

Product Details

Product Name: RX2-433
Model Number(s): RX2-433-40-5V
RX2-433-14-3V
RX2-433-40-3V
RX2-433-14-5V
RX2-433-160-3V
RX2-433-160-5V
RX2-433-40-TR
RX2-433-40-B
TCF Reference Number: RM/RX2/DTD
Standard(s): EN 300 220-1 V1.3.1 (2000-09) according to the requirements of EN
300 220-3 V1.1.1 (2000-09)
Description: UHF Radio Telemetry Receive Module

In the opinion of RFI, the Technical Construction File demonstrates that the Apparatus to which it relates conforms to the essential requirements of Article 3.2 of Council Directive 1999/5/EC on radio equipment and telecommunications terminal equipment and the mutual recognition of their conformity.

Authorised Signatory:

A handwritten signature in black ink, appearing to read 'N Cobb', is written over a horizontal line.

Mr N Cobb

16-10-01

Date



Company Seal

Notified Body Number - 0889

Radio Frequency Investigation Ltd, Ewhurst Park, Ramsdell, Basingstoke, Hampshire RG26 5RQ, ENGLAND
Tel: +44 (0) 1256 851193 Fax: +44 (0) 1256 851192 E-mail: sales@rfi.co.uk
Registered In England, No. 211 7901

Radiometrix Ltd
Hartcran House
231 Kenton Lane
Harrow, Middlesex
HA3 8RP
ENGLAND
Tel: +44 (0) 20 8909 9595
Fax: +44 (0) 20 8909 2233
sales@radiometrix.com
www.radiometrix.com

Copyright notice

This product data sheet is the original work and copyrighted property of Radiometrix Ltd. Reproduction in whole or in part must give clear acknowledgement to the copyright owner.

Limitation of liability

The information furnished by Radiometrix Ltd is believed to be accurate and reliable. Radiometrix Ltd reserves the right to make changes or improvements in the design, specification or manufacture of its subassembly products without notice. Radiometrix Ltd does not assume any liability arising from the application or use of any product or circuit described herein, nor for any infringements of patents or other rights of third parties which may result from the use of its products. This data sheet neither states nor implies warranty of any kind, including fitness for any particular application. These radio devices may be subject to radio interference and may not function as intended if interference is present. We do NOT recommend their use for life critical applications.

The Intrastat commodity code for all our modules is: 8542 6000

R&TTE Directive

After 7 April 2001 the manufacturer can only place finished product on the market under the provisions of the R&TTE Directive. Equipment within the scope of the R&TTE Directive may demonstrate compliance to the essential requirements specified in Article 3 of the Directive, as appropriate to the particular equipment.

*Further details are available on The Office of Communications (Ofcom) web site:
http://www.ofcom.org.uk/radiocomms/ifi/licensing/licensing_policy_manual/*

*Information Requests
Ofcom
Riverside House
2a Southwark Bridge Road
London SE1 9HA
Tel: +44 (0)845 456 3000 or 020 7981 3040
Fax: +44 (0)20 7783 4033
information.requests@ofcom.org.uk*

*European Radiocommunications Office (ERO)
Peblingehus
Nansensgade 19
DK 1366 Copenhagen
Tel. +45 33896300
Fax +45 33896330
ero@ero.dk
www.ero.dk*
