



TX1M/RX1M

Issue 3, 02 August 2012

VHF Narrow Band FM multi channel TX and RX

The TX1M transmitter and RX1M receiver modules offer a low power, reliable data link in an industry-standard pin out and footprint. This makes the TX1M/RX1M pair ideally suited to those low power applications where existing wideband modules have insufficient range, or where multi-channel operation is needed in VHF frequency.



TX1M-151-5

RX1M-151-5

Features

- Conforms to EN 300 220-3 and EN 301 489-3
- Any custom band in 60 - 65MHz with 1MHz or 135 - 175MHz with 3MHz (AR0) frequency range
- Data rates up to 5 kbps for standard module
- Usable range over 1km (@100mW)
- Fully screened. Low profile
- Feature-rich interface (RSSI, automatic noise squelch, analogue and digital baseband)
- Incorporate a 1200baud dumb modem
- Re-programmable via RS232 interface
- Low power requirements

Applications

- Handheld terminals
- EPOS equipment, barcode scanners
- Data loggers
- Industrial telemetry and telecommand
- In-building environmental monitoring and control
- High-end security and fire alarms
- Vehicle data up/download

Technical Summary

- Size: 59 x 38 x 7mm
- Operating frequency: 60-65MHz or 135 – 175MHz
- 128 serial select or 8 parallel select channels
- Transmit power: +20dBm (100mW) nominal
- Supply range: 4.5V - 15V
- Current consumption: 110mA transmit, 13mA receive
- Data bit rate: 5kbps max. (standard module)
- Receiver sensitivity: -118dBm (for 12 dB SINAD)
- Receiver blocking -85dB

Evaluation platforms: NBEK + XX2M carrier

RX1M

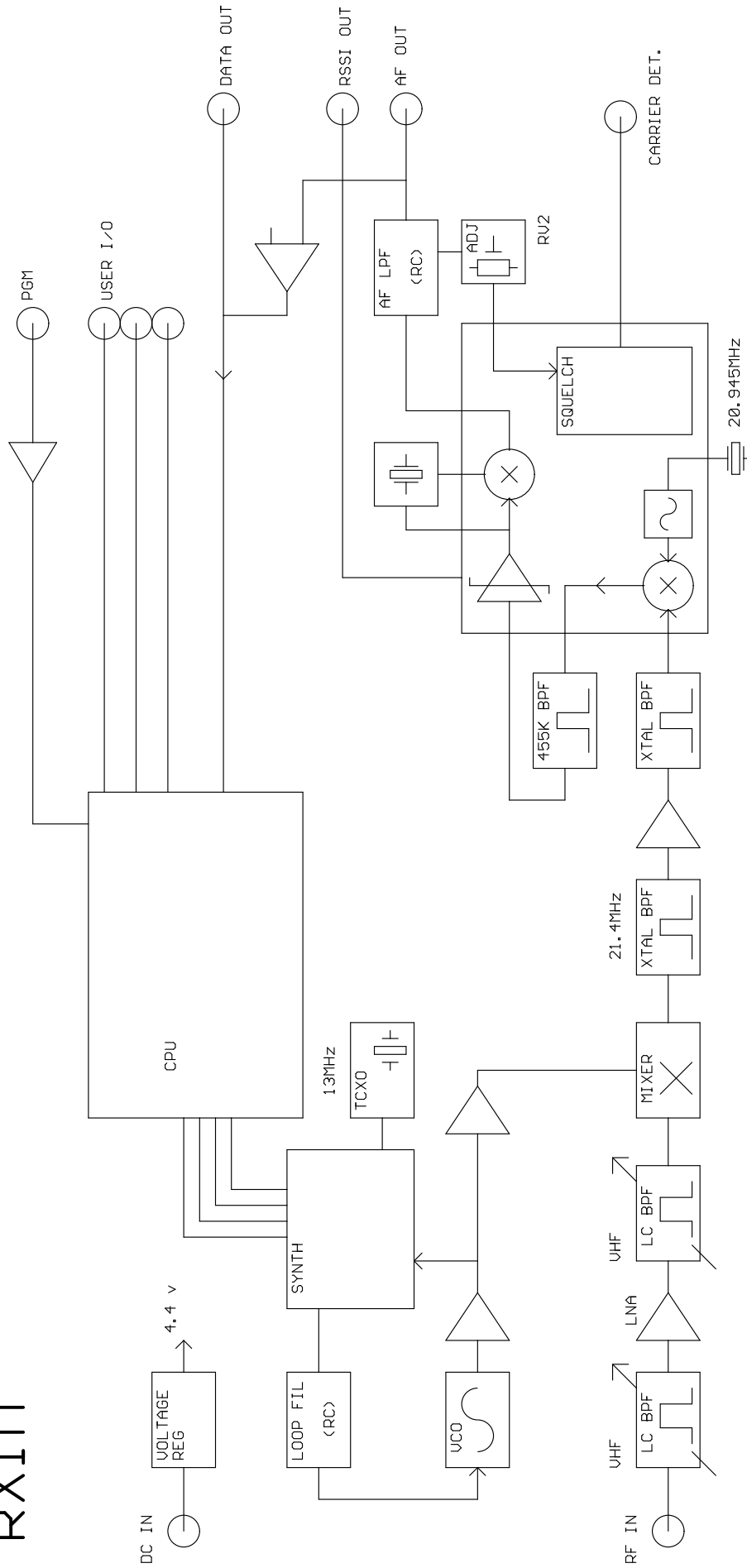

Figure 2: RX1M block diagram

Pin Description – TX1M

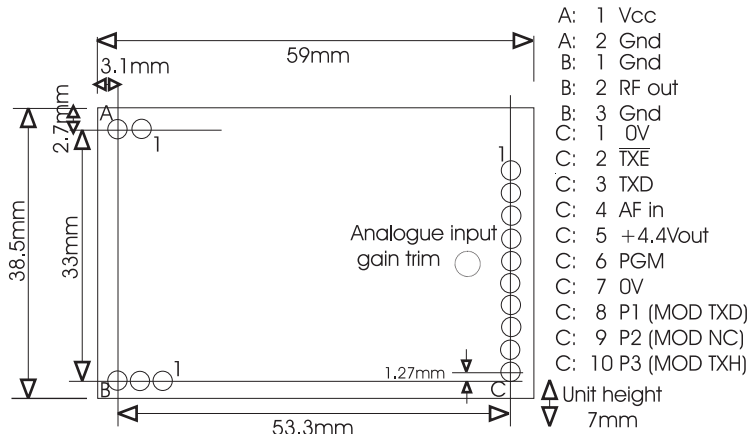

Figure 3: TX1M Footprint (Top) view

Pin	Name	Function
1A	Vcc	4.5 – 15V
2A	Gnd	Ground
1B	Gnd	RF ground
2B	RF out	To the antenna
3B	Gnd	RF ground
1C	0V	Ground
2C	TXE	Transmitter enable. Low = ON, open = off. 4k7 internal pullup to Vcc
3C	TXD	DC coupled input for 3-12V CMOS logic. Leave open if unused
4C	AF in	AC coupled Analogue Input. Limit to $1V_{pk-pk} \pm 10\%$ to keep distortion <1.5% and peak FM deviation >2.5kHz (>2kHz for 60-65MHz)
5C	+4.4Vout	DC supply. 75mA maximum drain. Only present when TXE is low
6C	PGM	Serial programming/configuration input at RS232 level
7C	0V	Ground
8C	P1 (MOD TXD)	Parallel frequency select inputs. Inverted logic, 10k pullups to 4V
9C	P2 (MOD NC)	
10C	P3 (MOD TXH)	

Notes:

- Internal AF Input gain is factory set for $1V_{pk-pk}$ to produce 3kHz peak deviation and minimum distortion. Analogue gain may be set for an input level of $50mV - 2V_{pk-pk}$. This cannot be done without appropriate test equipment. Contact factory for details
- With 1200baud modem mode enabled, parallel selection of channel is unavailable as the P1-P3 lines are used for input/output operations.

3. Pin Description – RX1M

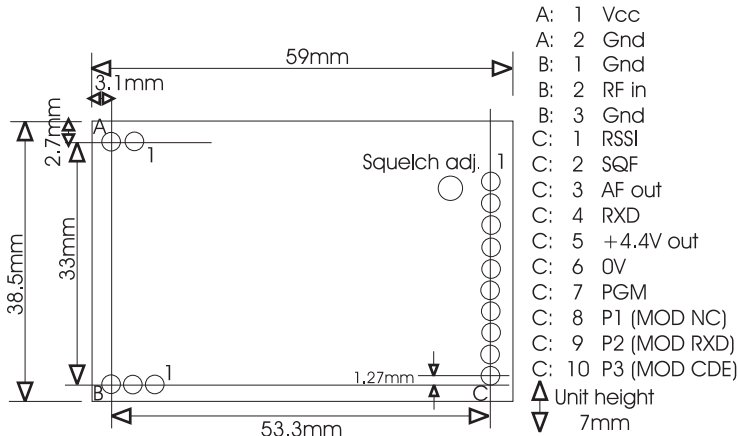

Figure 4: RX1M Footprint (Top) view

Pin	Name	Function
1A	Vcc	4.5-15V
2A	Gnd	Ground
1B	Gnd	RF ground
2B	RF out	To the antenna
3B	Gnd	RF ground
1C	RSSI	DC level between 0.5V and 2.5V. 60dB dynamic range
2C	SQF	Noise operated carrier detect. Open collector. ON/low = no signal
3C	AF out	200mV _{pk-pk} audio. DC coupled, approx 1V bias. Muted by squelch
4C	RXD	Open collector output of data slicer. Need external pull-up
5C	+4.4V out	DC supply. 75mA maximum drain. Present if unit is powered.
6C	0V	Ground
7C	PGM	Serial programming/configuration input at RS232 level
8C	P1 (MOD NC)	Parallel frequency select inputs. Inverted logic, 10K pullups to 4V
9C	P2 (MOD RXD)	
10C	P3 (MOD CDE)	

Notes:

1. Carrier detect on RX1M mutes the AF and RXD outputs when RF input signal is <-123dBm. This can be factory disabled if required.
2. There are no pullups on the open collector outputs. External pull-up resistor should be used.
3. With 1200baud modem mode enabled, parallel selection of channel is unavailable as the P1-P3 lines are used for input/output operations.

TX1M and RX1M serial interface commands

2400 baud at RS232 level. 8 bit data, no parity, 1 start bit, 1 or 2 stop bits, No flow control.
Transmit (pin 3 on DB9) and Signal Ground (pin 5 on DB9) should be connected to PGM and 0V pin.

Command Format	Description
SINGLE nnnnn	Set value of N for single channel operation
GOCHAN xx	Serial select of channel xx (0 to 127)
LOADMX xx	Set highest permitted (serial selected) channel xx (others default to ch0)
LOADaa nnnnn	Set value of N for channel aa (channels 0 to 15)
LOADTB nnnnn	Set value of N for channel 16 (channels 17 to 127 then in sequence)
RVALUE rrrr	Enter value for R register
SETPAR	Channel selected by 3 bit parallel input (0 to 7). Disable modem
SETSER	Channel selected by most recent GOCHAN operation
SETMOD	Enable internal modem. Frequency selected by most recent GOCHAN or SINGLE
<CR>	Process entry (Carriage Return = 0D hex)
/	Clear all buffers

xx = channel number from 00 to 127
aa = two digit channel number from 00 to 15
nnnnn = synthesizer N register value, (up to 65535)
rrrr = synthesizer R register value, (up to 16383)

$$N_{TX} = \frac{f_{RF}}{f_{Channelspacing}} = \frac{173.250MHz}{25kHz} = 6930 \quad R = \frac{f_{TCXO}}{f_{channelspacing}} = \frac{13MHz}{25kHz}, \text{ So } R=520$$

$$N_{RX} = \frac{f_{RF} - 21.4MHz}{f_{Channelspacing}} = \frac{171.250MHz - 21.4}{25kHz} = 6140$$

Notes:

1. A pause of at least 50ms must be allowed between command strings (EEPROM programming time) SINGLE mode does not store the N value in EEPROM. Therefore the unit is inoperative after a power down until either another valid SINGLE command is received, or mode is changed by a GOCHAN, SETPAR or SETSER command. SINGLE mode is intended for frequency agile applications.
2. /SETPAR command should be issued at the end of channel programming to put the module back into parallel frequency select mode.

Pin description of TX1M/RX1M with Modem mode selected

The 'modem' mentioned is a 1200 baud RS232 semi-intelligent unit (Transmitter is enabled when valid serial data is present, so no separate Transmit Enable control is needed. Coding in the data stream also permits the receiver to ignore noise and only output valid serial data.

Pin Description – TX1M

Pin	Name	Function
1	0V	Ground
2	$\overline{\text{TXE}}$	Must be tied to 0V
3	N/C	
4	N/C	
5	+4.4Vout	DC supply. 75mA maximum drain. Only present when $\overline{\text{TXE}}$ is low
6	PGM	Serial programming/configuration input at RS232 level
7	0V	Ground
8	MOD TXD (P1)	Serial data input at RS232 level
9	MOD N/C (P2)	
10	MOD TXH (P3)	Active Low Transmit Hold for continuous transmission (useful for test)

Pin Description – RX1M

Pin	Name	Function
1	RSSI	DC level between 0.5V and 2.5V. 60dB dynamic range (only valid during databursts)
2	N/C	
3	N/C	(modem tones or noise present)
4	N/C	(modem tones or noise present)
5	+4.4V out	DC supply. 75mA maximum drain. Present if unit is powered
6	0V	Ground
7	PGM	Serial programming/configuration input at RS232 level
8	MOD N/C (P1)	
9	MOD RXD (P2)	Modem Received Data at TTL level (requires RS232 driver)
10	MOD CDE (P3)	Pull low to enable Carrier Detect on modem operation (not recommended)

Both the TX1M and the RX1M should be configured to required operating frequency using GOCHAN command before starting to use the internal 1200 baud modem, because the P1-P3 pins will be used as Modem Data pins and the modem will operate on the last serially selected channel after SETMOD command is used to enable the Modem.

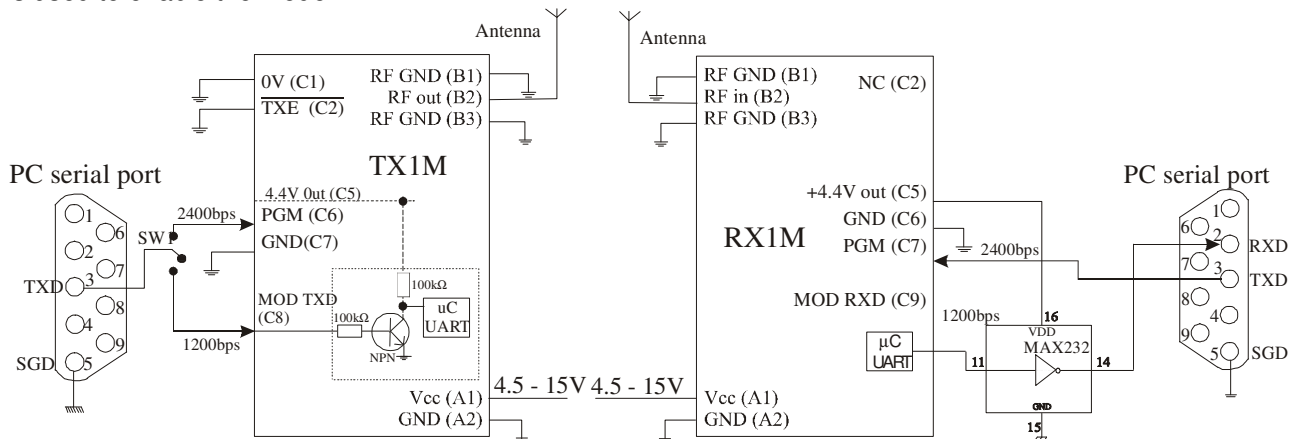

Figure 5: TX1M and RX1M interfaced to PC serial port in modem mode

Note: Baud rate used for Modem is half that of used for serial configuration. Attached RS232 devices should be set with the following: 1200bps, 8 Data bits, No Parity, 1/2 stop bits, no flow control

For TX1M, TXD (Pin 3) of a Serial Port can be switched from PGM (Pin C6) to MOD TXD (Pin C8) with no RS232 driver in between. However, in RX1M, MOD RXD (Pin C9) requires an RS232 line driver before it can be connected to RXD (pin 2) of a serial port. Some of the RS232 line drivers can be powered from the regulated +4.4V out (Pin C5).

Condensed specifications

Frequency	TX1M/RX1M: any 1MHz from 60 - 65MHz	
	TX1M: any 3MHz band from 135-175MHz	
	RX1M: any 2MHz band from 130-180MHz	
<i>Frequency stability</i>	+/- 1.5kHz	
<i>Channel spacing</i>	25kHz (12.5kHz by special order)	
<i>Number of channels</i>	128 channels controlled via RS232 interface (8 parallel selected)	
Operating temperature	-10 to +60 °C (Storage -30 to +70 °C)	
Size	59 x 38 x 7 mm	
Spurious radiations	Compliant with ETSI EN 300 220-3 and EN 301 489-3	
Interface		
<i>User</i>	8pin 0.1" pitch molex	
<i>Power</i>	2pin 0.1" pitch molex	
<i>RF</i>	3pin 0.1" pitch molex	
Transmitter		
Output power	+20dBm(100mW) ± 1dB (factory adjustable 10 - 200mW)	
TX on switching time	50 ms	
Modulation type	FM, FSK (F1D, F3D)	
TX modulation bandwidth	DC – 3kHz	
FM deviation	> ±2.5kHz (>±2kHz for 60 - 65MHz)	
Adjacent channel TX power	-37dBm	
Spurii	<-40dBm	
Inputs	analogue, data (CMOS/TTL compatible)	
Supply <i>Voltage</i>	4.5 - 15V	
<i>Current</i>	@ 10mW : 50mA @ 100mW: 110mA @ 200mW: 150mA	
Receiver		
Sensitivity	-118dBm for 12 dB SINAD (for 135-175MHz)	
	-117dBm for 12 dB SINAD (for 60-65MHz)	
image / spurious	-70dB	
Blocking	-85dB	
adjacent channel	<-65dB (Tested per. ETSI EN 301 489-3, squelch disabled)	
Spurious radiations	<-60dBm	
Outputs	RSSI, carrier detect, audio, data	
Supply <i>Voltage</i>	4.5 - 16V	
<i>Current</i>	13mA	
Power on to valid audio	28ms (no noise mute) 45ms (with noise mute)	
Power on to stable data out	50ms (with or without mute) for 50:50 mark / space	

Notes

1. The data slicer cannot be depended upon for data waveform frequencies below 250Hz
2. When RX is on and a transmitter keys up, again a 50ms period is required to stabilise data output mark/space. i.e. allow at least 50ms of preamble
3. For UK version the following channel assignment is supplied:

Channel	Frequency (MHz)
0	173.250
1	173.275
2	173.300
3	173.325
4 - 7	173.225 (only used for alarm applications)
8 - 127	173.325

4. For Australian version the following channel assignment is supplied:

Channel	Frequency (MHz)	N vlaue
0	150.825	/LOAD 00 6033
1	150.850	/LOAD 01 6034
2	150.875	/LOAD 02 6035
3	150.900	/LOAD 036036
4	150.925	/LOAD 04 6037
5	150.950	/LOAD 05 6038
6	150.975	/LOAD 06 6039
7	151.000	/LOAD 07 6040
8	151.025	/LOAD 08 6041
9	151.050	/LOAD 09 6042
10	151.075	/LOAD 10 6043
11	151.100	/LOAD 11 6044
12	151.125	/LOAD 12 6045
13	151.150	/LOAD 13 6046
14	151.175	/LOAD 14 6047
15	151.200	/LOAD 15 6048
16	151.225	/LOADTB 6049
17 - 65	in sequence starting at CH 17 (151.250)	

Operating principle of internal modem

This device is a simplex link handling a 1200 baud asynchronous datastream (1 start, 8data, 1stop). Buffering in the transmit end handles TX startup timing requirements, while the presence of sync codes in the transmitted bursts prevents the receiver from outputting garbage in the presence of noise. No error correction or retransmission of lost packets is supported. To operate with proper +/-12V RS232 levels an external buffer (such as a MAX232) will be needed

Physically the modem code resides in the PIC microcontroller which controls the radio functions. The modem uses the internal hardware serial port of the processor.

Operation: Serial interface

Both transmit and receive modems implement a 32 byte software FIFO. At the transmit end this is used to allow for the TX1M transmitter start up time (about 32mS), while on receive it buffers arriving packets to the constant output data rate. All timing and data formatting tasks are handled by the software. The user need not worry about keying the transmitter before sending data: the link is entirely transparent.

For transmission across the link data is formatted into packets, each comprising 3 bytes of data and a sync code. If less than 3 bytes are in the transmit end FIFO then a packet is still sent, but idle state replaces the unused bytes. When the transmit end FIFO is completely emptied, then the transmitter is keyed off .

Operation: Radio interface

Raw data is not fed to the radios. A coding operation in the transmit software, and decoding in the receiver, isolate the AC coupled, potentially noisy baseband radio environment from the datastream.

The radio link is fed a continuous tone by the modem. As in biphase codes, information is coded by varying the duration consecutive half-cycles of this tone. In our case half cycles of 500µs (a long, or L) and 250µs (a short, or S) are used. In idle (or 'preamble') state, a sequence of Ls is sent (resembling a 1kHz tone).

A packet comprises the Synchronising (or address) part : LSSSSSSSSSSSL followed by the Data part, made up of twelve Groups (of four half cycles duration). Each Group encodes 2 data bits, so one byte is encoded by 4 Groups. Although there are 16 possible states for a four half cycle group (from SSSS to LLLL), only four of the possible states are used for valid data:

All other possible group combinations (except LLLL) are void, and result in the entire packet being rejected by the receiver software as a noise artifact. Idle state tone (LLLL) is decoded as null data, but does not void the packet, as a packet containing less than 3 bytes still needs to be decoded.

Application circuits

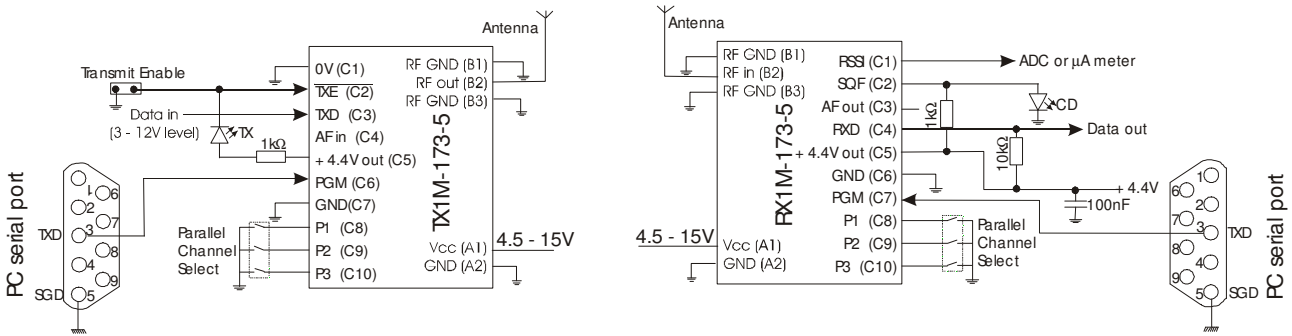

Figure 6: Test circuit of TX1M and RX1M

TX1M/RX1M can be configured using any PC/Laptop/PDA having a serial port and modem/terminal program. TXD (pin 3) of DB9M connector can be directly wired to PGM (pin C7) of the TX1M/RX1M and SGN (pin 5) of DB9M connector should be connected to common ground pins.

The whole frequency/channel table is user reconfigurable to 128 channels within 2MHz band of supplied frequency subject to regulatory band limits.

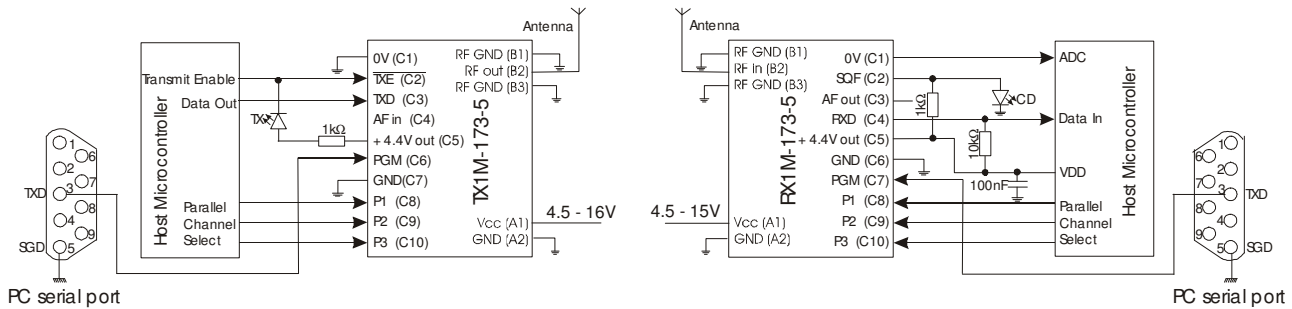

Figure 7: TX1M and RX1M interfaced to host microcontroller and serial port for configuration

TX1M and RX1M can be directly interfaced to a host microcontroller which can generally be powered by the regulated +4.4V output on pin 5. Three I/O pins on the microcontroller port can be assigned to select the first 8 channels on frequency table of the appropriate band for which the module is configured by pulling the P1-P3 pins low. Channel select pins of TX1M and RX1M have internal pull-up to 4V supply rail, hence channel selection operate on inverted logic.

Digital Received Data Output (RXD) pin on the RX1M is an open collector output, which should be pulled-up to required voltage swing level (e.g. +4.4V or Vcc).

RX1M has an automatic noise squelching function which is activated when there is not any RF signal at detectable level on the channel or if the non-coherent noise like interference level is high enough to block any weak RF signal from being received. SQF is provided as an open-collector output for monitoring which should be pulled-up to required voltage swing level. SQF output will jump to pull-up voltage level if received RF signal level at the RF In/Out pin of the module is about 3dB below the level required to produce 12dB SINAD level on demodulated AF Output signal. SQF pin can be connected to an LED to act as a Carrier Detect indicator. Pull-up resistor value should be reduced (e.g. 1kΩ) according to the current requirement to produce satisfactory brightness on the LED used.

Transmitter variant

RX1M in 135-175MHz is designed to be pin and polarity compatible with existing industry standard modules. AF and Data Output are inverted relative to original transmitted signal. However, RX1M in 60-65MHz band does not invert the baseband sense.

The transmitter in 135-175MHz is available in two variants – TX1I and TX1M

The non-inverting transmitter called TX1M frequency modulates the carrier frequency in the normal sense whereby higher modulating voltage increases the carrier frequency and lower modulating voltage decreases the carrier frequency which results in an inverted AF and Data output on the receiver. This will be the standard module and exact plug-in replacement for existing industry standard modules.

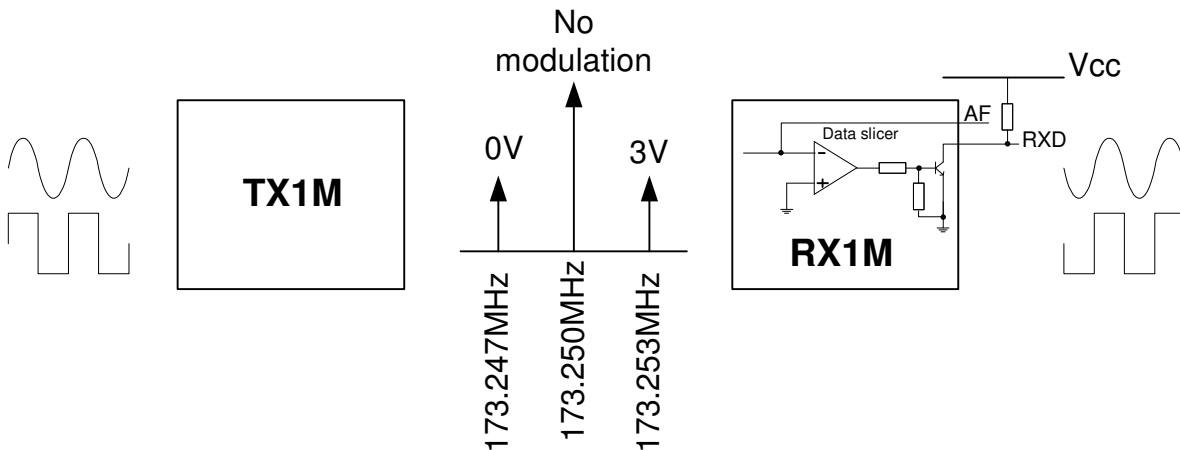

Figure 8: Data polarity change from TX1M (non-inverting) transmitter to RX1M receiver

The inverting transmitter called TX1I reverses the Frequency Modulating order whereby the higher modulating voltage decreases the carrier frequency and lower modulating voltage increases carrier frequency which results in non-inverting AF and Data output on the receiver. This variant can be used for applications where data inversion will be problematic.

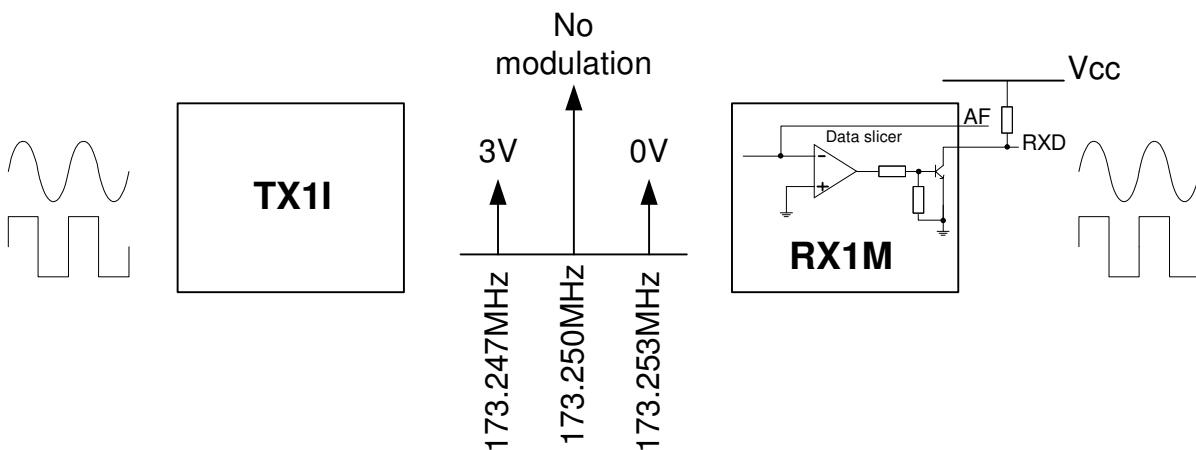

Figure 9: Data polarity change from TX1I (inverting) transmitter to RX1M receiver

Ordering information

Part Number	Description	Frequency band	Maximum data rate
TX1M-xxx-5	TX1M transmitter	Where xxx is any 1MHz band from 60-65MHz	5kbps
RX1M-xxx-5	RX1M receiver		5kbps
TX1M-xxx-5	TX1M (non-inverting) transmitter	Where xxx is any 3MHz band from 135-175MHz for TX1M and any 2MHz band from 130-180MHz for RX1M	5kbps
TX1I-xxx-5	TX1I (inverting) transmitter		5kbps
RX1M-xxx-5	RX1M receiver		5kbps
TX1M-xxx-10	TX1M (non-inverting) transmitter		10kbps
TX1I-xxx-10	TX1I (inverting) transmitter		10kbps
RX1M-xxx-10	RX1M receiver		10kbps

Radiometrix Ltd

**Hartcran House
231 Kenton Lane
Harrow, Middlesex
HA3 8RP
ENGLAND**

**Tel: +44 (0) 20 8909 9595
Fax: +44 (0) 20 8909 2233
sales@radiometrix.com
www.radiometrix.com**

Copyright notice

This product data sheet is the original work and copyrighted property of Radiometrix Ltd. Reproduction in whole or in part must give clear acknowledgement to the copyright owner.

Limitation of liability

The information furnished by Radiometrix Ltd is believed to be accurate and reliable. Radiometrix Ltd reserves the right to make changes or improvements in the design, specification or manufacture of its subassembly products without notice. Radiometrix Ltd does not assume any liability arising from the application or use of any product or circuit described herein, nor for any infringements of patents or other rights of third parties which may result from the use of its products. This data sheet neither states nor implies warranty of any kind, including fitness for any particular application. These radio devices may be subject to radio interference and may not function as intended if interference is present. We do NOT recommend their use for life critical applications.

The Intrastat commodity code for all our modules is: 8542 6000

R&TTE Directive

After 7 April 2001 the manufacturer can only place finished product on the market under the provisions of the R&TTE Directive. Equipment within the scope of the R&TTE Directive may demonstrate compliance to the essential requirements specified in Article 3 of the Directive, as appropriate to the particular equipment.

Further details are available on The Office of Communications (Ofcom) web site:

<http://www.ofcom.org.uk/>

Information Requests

Ofcom

Riverside House

2a Southwark Bridge Road

London SE1 9HA

Tel: +44 (0)300 123 3333 or 020 7981 3040

Fax: +44 (0)20 7981 3333

information.requests@ofcom.org.uk

European Communications Office (ECO)

Pebblinghus

Nansensgade 19

DK 1366 Copenhagen

Tel. +45 33896300

Fax +45 33896330

ero@ero.dk

www.ero.dk
