

**NEW**

# Radiometrix

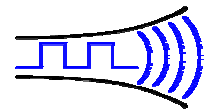

Hartcran House, 231 Kenton Lane, Harrow, HA3 8RP, England

Tel: +44 (0) 20 8909 9595, Fax: +44 (0) 20 8909 2233

Issue 2, 03 June 2008

**TR2M**

## Narrow Band FM Multi-channel UHF Transceiver

*UK Version: TR2M-458-5, TR2I-458-5 (100mW)*

*European version: TR2M-433-5, TR2I-433-5 (10mW)*

*The TR2M transceiver module offers a low power, reliable data link in an industry-standard pin out and footprint. This makes the TR2M ideally suited to those low power applications where existing wideband modules have insufficient range, or where multi-channel operation is needed. Two versions are available, covering the 458.5-459.1MHz UK band (at 100mW) and the European 433.05-434.79MHz band (at 10mW).*



*Figure 1: TR2I-433-5 transceiver*

### Features

- ◆ 433MHz version conforms to EN 300 220-3 and EN 301 489-3  
458MHz version to MPT 1329 (UK specs).
- ◆ Any 5MHz band module from 420MHz to 480MHz available as factory tuned custom variant
- ◆ High performance double superhet, 128 channel PLL Synthesizer with TCXO
- ◆ Data rates up to 5 kbps for standard module
- ◆ Usable range over 1km (with 100mW variant)
- ◆ Fully screened
- ◆ Feature-rich interface (RSSI, automatic noise squelch, analogue and digital baseband)
- ◆ Incorporates a 1200baud dumb modem
- ◆ User configurable via RS232 interface
- ◆ Low power requirements

### Applications

- ◆ Handheld terminals
- ◆ Heavy vehicle/machine remote controls
- ◆ EPOS equipment, barcode scanners
- ◆ Data loggers
- ◆ Industrial telemetry and telecommand
- ◆ In-building environmental monitoring and control
- ◆ High-end security and fire alarms
- ◆ Vehicle data up/download

### Technical Summary

- ◆ Operating frequency: 458.5-459.1MHz or 433.05-434.79MHz
- ◆ Custom variants from 420MHz to 480MHz on any 5MHz band
- ◆ 23 channels in 458MHz band, 69 channels in 433MHz band (128 channels max.)
- ◆ Transmit power: +20dBm (100mW) nominal
- ◆ Supply range: 4.5V - 16V
- ◆ Current consumption: 110mA transmit, 27mA receive
- ◆ Data bit rate: 5kbps max. (standard module)
- ◆ Receiver sensitivity: -118dBm (for 12 dB SINAD)
- ◆ Size: 59 x 38 x 10mm

# TR2C 458

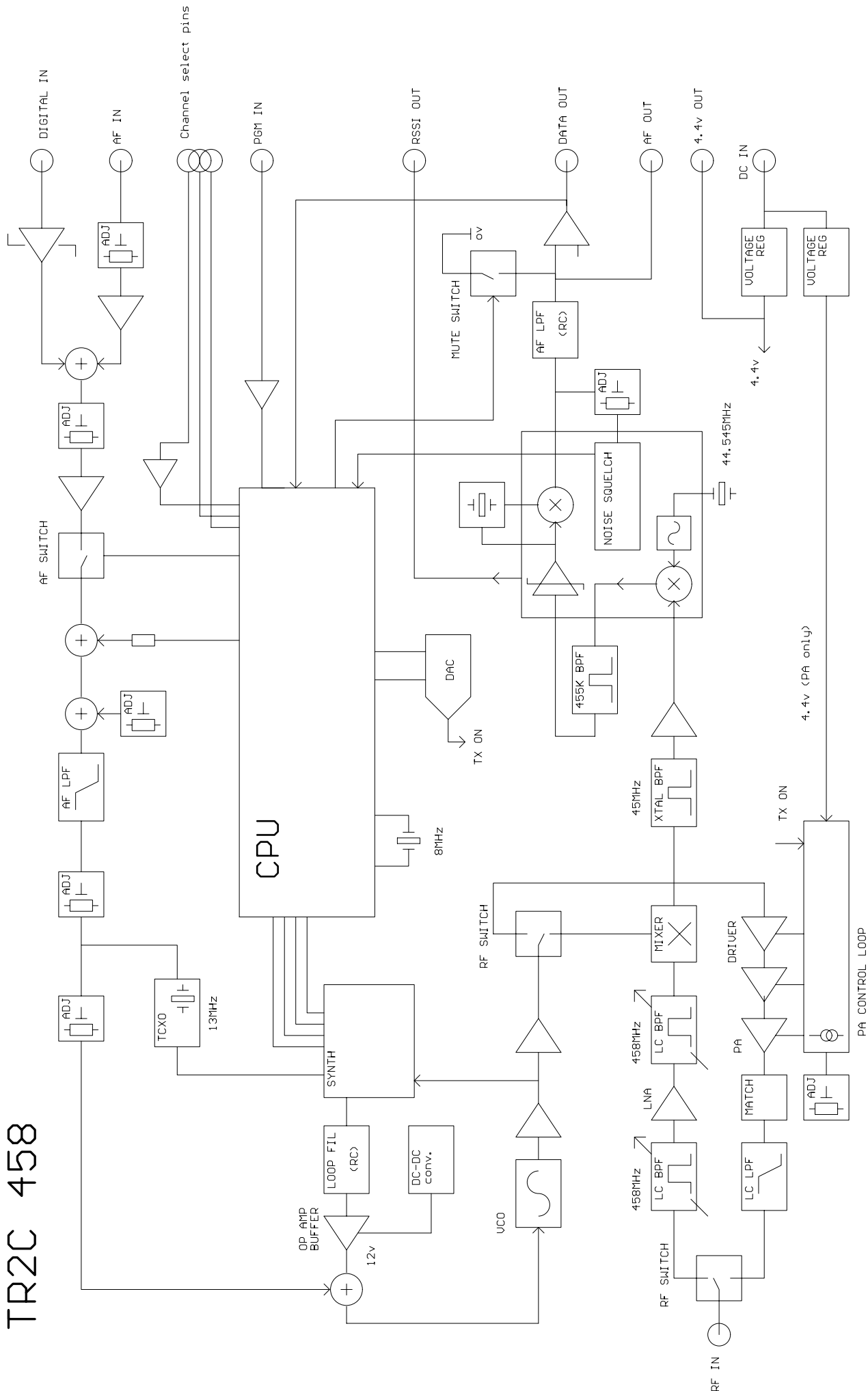
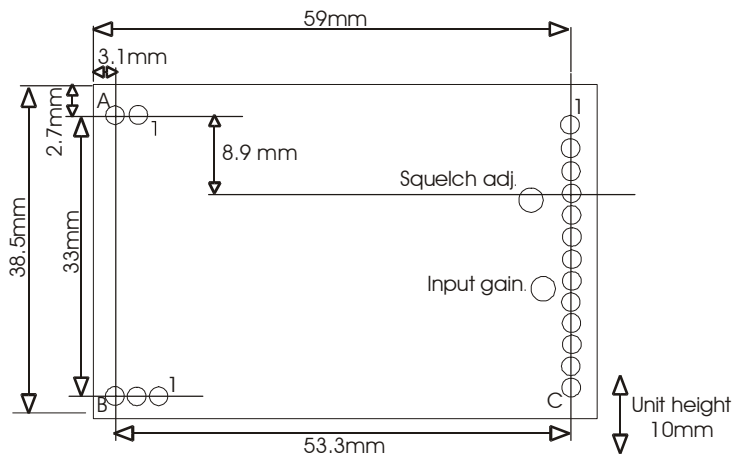

Figure 2: TR2M block diagram

- A: 1 Vcc
- A: 2 Gnd
- B: 1 RF Gnd
- B: 2 RF in
- B: 3 RF Gnd
- C: 1 TXE (MOD TX\_ON)
- C: 2 TXD (MOD NC)
- C: 3 AF in (MOD NC)
- C: 4 RSSI
- C: 5 SQF (MOD NC)
- C: 6 AF out
- C: 7 RXD (MOD NC)
- C: 8 +4.4V out
- C: 9 0V
- C: 10 PGM
- C: 11 P1 (MOD TXD)
- C: 12 P2 (MOD RXD)
- C: 13 P3 (MOD NC)



**Figure 3: TR2M Footprint (Top)**

## Pin Description - TR2M

Pins	Name	Function
A1	Vcc	4.5V-16V
A2	GND	Ground
B1	RF GND	RF ground
B2	RF	To the antenna
B3	RF GND	RF ground
C1	TXE (MOD TX_ON)	Transmitter Enable. Low = ON, Open = RX mode. Internal 10kΩ pull-up to 4V
C2	TXD (MOD NC)	DC coupled digital data input for 3-12V CMOS logic. Leave open if unused
C3	AF in (MOD NC)	AC coupled Analogue Input Limit to 1V <sub>pk-pk</sub> ±10% to keep distortion <1.5% and peak deviation >2.5kHz
C4	RSSI	DC level between 0.5V and 2.5V. 60dB dynamic range
C5	SQF (MOD NC)	Noise operated carrier detect. Open collector. ON/low = no signal
C6	AF out	200mV <sub>pk-pk</sub> audio. DC coupled, approx 1V bias. Muted by squelch
C7	RXD (MOD NC)	Open collector output of data slicer suitable for Biphase codes
C8	+4.4V out	Regulated DC supply. 75mA max. drain. Present if unit is powered
C9	0V	Ground
C10	PGM	Serial programming/configuration input at RS232 level
C11	P1 (MOD TXD)	Parallel frequency select inputs. Inverted logic, internal 10kΩ pullups to 4V
C12	P2 (MOD RXD)	
C13	P3 (MOD NC)	

### Notes:

1. Carrier detect on TR2M mutes the AF Out and RXD outputs. It can be factory disabled.
2. All the open collector outputs must be connected to Vcc/+4.4V out via a pull-up resistor.
3. The software incorporates a 1200baud dumb modem, compatible with that implemented in TX2M, RX2M radios (I1200 tones and format)
4. With 1200baud modem mode enabled, parallel selection of channel is unavailable as the P1-P3 lines are used for modem input/output operations.
5. PGM and MOD TXD (pin 10 and 11) tolerate true ±RS232 levels. No buffering is required.

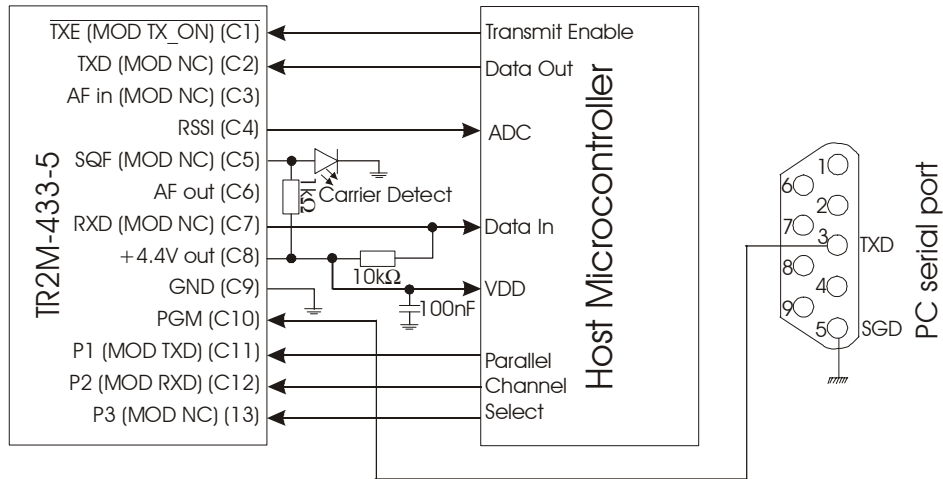

**Figure 4: TR2M interfaced to host microcontroller and serial port for configuration**

TR2M can be directly interfaced to a host microcontroller which can generally be powered by the regulated +4.4V output on pin 8 of TR2M. Three I/O pins on the microcontroller port can be assigned to select the first 8 channels on frequency table of the appropriate band for which the module is configured by pulling the P1-P3 pins low. Channel select pins of TR2M have internal pull-up to 4V supply rail, hence channel selection operate on inverted logic.

Channel	P3:P2:P1	433MHz band	458MHz band
0	111	433.050	458.525
1	110	433.075	458.550
2	101	433.100	458.575
3	100	433.125	458.600
4	011	433.150	458.625
5	010	433.175	458.650
6	001	433.200	458.675
7	000	433.225	458.700

Digital Received Data Output (RXD) pin is an open collector output, which should be pulled-up to required voltage swing level (e.g. +4.4V or Vcc).

TR2M has an automatic noise squelching function which is activated when there is not any RF signal at detectable level on the channel or if the non-coherent noise like interference level is high enough to block any weak RF signal from being received. SQF is provided as an open-collector output for monitoring which should be pulled-up to required voltage swing level. SQF output will jump to pull-up voltage level if received RF signal level at the RF In/Out pin of the module is about 3dB below the level required to produce 12dB SINAD level on demodulated AF Output signal. SQF pin can be connected to an LED to act as a Carrier Detect indicator. Pull-up resistor value should be reduced (e.g. 1kΩ) according to the current requirement to produce satisfactory brightness on the LED used.

TR2M can be configured using any PC/Laptop/PDA having a serial port and modem/terminal program. TXD (pin 3) of DB9M connector can be directly wired to PGM (pin C10) of the TR2M and SGN (pin 5) of DB9M connector should be either connected to common ground or pin C9 of the TR2M.

The whole frequency/channel table is user reconfigurable to 128 channels within 5MHz band of supplied frequency subject to regulatory band limits. Serial Channel Selection via PGM pin gives access to the whole of regulatory band allocation for 433.05MHz-434.790MHz (69 channels) or 458.525MHz-458.925MHz (23 channels).

## Received Signal Strength

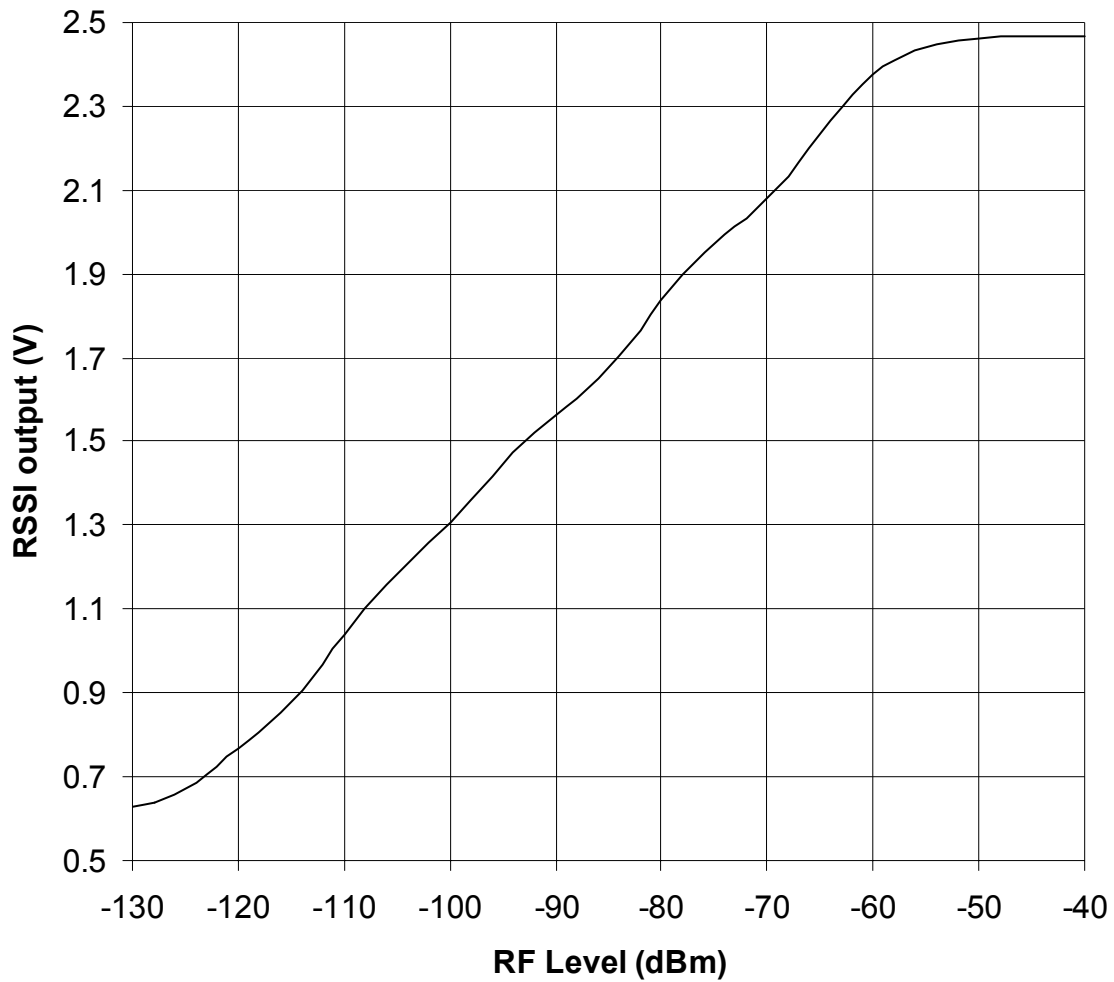

**Figure 5: RSSI voltage variation with respect to RF level at TR2M**

If the microcontroller has a built-in Analogue to Digital Converter (ADC), the Received Signal Strength Indicator (RSSI) output voltage level can be read by the microcontroller to estimate its distance from transmitting TR2M unit or identify areas of weak signal reception.

RSSI can also be used to make a decision to switch to the second antenna in fixed installations within building where the probability of null-spots are higher.

### Regulatory Restrictions

There is a generic 10% duty cycle restriction on the 433MHz ISM band through out European countries with few exceptions. Annex 1 Band E, Band E2 of European Radio Communications Committee (ERC) Recommendation 70-03 dated February 2004 specifies the following:

433.050MHz (Ch0)	434.050MHz (Ch40)	433.775MHz (Ch69)
<b>10mW ERP, 10% duty cycle for Channelised Narrow Band and Wide Band usage</b>		
		<b>10mW ERP, 100% duty cycle for &lt;25kHz Channelised Narrow Band usage</b>
<b>433.05MHz</b>	<b>434.040MHz</b>	<b>434.79MHz</b>

433.050-434.790 MHz, Non Specific Short Range Device, band is primarily intended for Telemetry, Telecommand, Alarms, Data in general and other similar applications. Audio and Voice signals should be avoided in the band.

## TR2M serial configuration commands

2400 baud RS232. 8 bit data, no parity, 1 start bit, 1 or 2 stop bits, No flow control

SINGLE nnnnn	Set value of N for single channel operation
GOCHAN xx	Serial select of channel xx (0 to 127)
LOADMX xx	Set highest permitted (serial selected) channel xx (others default to ch0)
LOAD aa nnnnn	Set value of N for channel aa (channels 0 to 15)
LOADTB nnnnn	Set value of N for channel 16 (channels 17 to 127 then in sequence)
RVALUE rrrr	Enter value for R register
SETPAR	Channel selected by 3 bit parallel input (0 to 7). Disable modem
SETSER	Channel selected by most recent 'gochan' operation
SETMOD	Enable internal modem. Frequency selected by most recent 'gochan' or 'single'
GOTEST	250Hz test tone transmission
OFFSET ooo	Set receive frequency offset (for 25KHz this is 1800)
<cr>	Process entry
/	Clear all buffers

xx = channel number from 00 to 127

aa = two digit channel number from 00 to 15

nnnnn = synthesizer N register value, (up to 65535)

rrrr = synthesizer R register value, (up to 16383)

ooo = frequency offset

$$N_{TX} = \frac{f_{RF}}{f_{Channelspacing}} = \frac{433.050MHz}{25kHz} = 17322$$

$$R = \frac{f_{TCXO}}{f_{channelspacing}} = \frac{13MHz}{25kHz}, \text{ So } R=520$$

$$RX \text{ OFFSET} = \frac{IF}{f_{channelspacing}} = \frac{45MHz}{25kHz} = 1800$$

Channel Number	433MHz band	N value for TX	458MHz band	N value for TX
0	433.050	/LOAD00 17322	458.525	/LOAD00 18341
1	433.075	/LOAD01 17323	458.550	/LOAD01 18342
2	433.100	/LOAD02 17324	458.575	/LOAD02 18343
3	433.125	/LOAD03 17325	458.600	/LOAD03 18344
4	433.150	/LOAD04 17326	458.625	/LOAD04 18345
5	433.175	/LOAD05 17327	458.650	/LOAD05 18346
6	433.200	/LOAD06 17328	458.675	/LOAD06 18347
7	433.225	/LOAD07 17329	458.700	/LOAD07 18348
8	433.250	/LOAD08 17330	458.725	/LOAD08 18349
9	433.275	/LOAD09 17331	458.750	/LOAD09 18350
10	433.300	/LOAD10 17332	458.775	/LOAD10 18351
11	433.325	/LOAD11 17333	458.800	/LOAD11 18352
12	433.350	/LOAD12 17334	458.825	/LOAD12 18353
13	433.375	/LOAD13 17335	458.850	/LOAD13 18354
14	433.400	/LOAD14 17336	458.875	/LOAD14 18355
15	433.425	/LOAD15 17337	458.900	/LOAD15 18356
16	433.450	/LOADTB 17338	458.925	/LOADTB 18357
<b>F max</b>	434.775	/LOADMX 69	459.100	/LOADMX 23

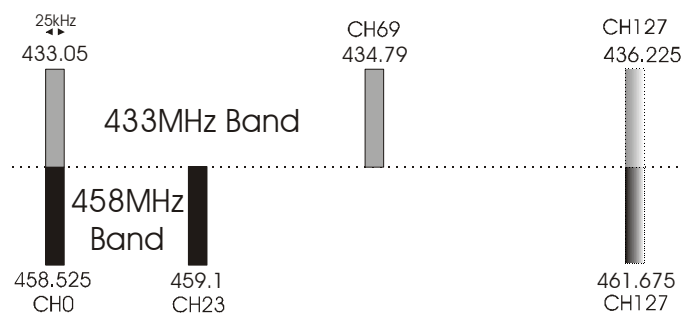

**Figure 6: Maximum regulatory and user accessible sequential channels**

```

TR2M - HyperTerminal
File Edit View Call Transfer Help

GOCHAN 69      Go to Ch69 (434.775MHz) highest channel on 433MHz band
GOCHAN 70      Go to Channel 70 will wrap back to Channel 0 (433.05MHz)
LOADMX 89      Increase maximum allowed Channel to 89 (435.275MHz)
GOCHAN 6       Serially select Channel 6 (433.200MHz)
SETPAR        Enable Parallel Channel Selection using P1:P2:P3
GOCHAN 88      Go to Channel 88 (435.250MHz) outside legal 433MHz band
GOCHAN 89      Go to new highest Channel 89 (435.275MHz)
/LOADMX 69     Set legal highest Channel as 69 (434.775MHz) below 434.790MHz
SETPAR        Go to Channel Selected by P1:P2:P3
SINGLE 17332    Set Synthesiser N value to 17332 to operate on 433.300MHz

SETPAR        Return to Parallel Frequency Selection
/LOAD03 17338  Change Channel 3 N value to 17338 to operate on 433.450MHz)
GOCHAN 3       Serially select newly set Channel 3 frequency of 433.450MHz
/LOAD03 17325  Set the Ch3 back to factory set N value 17325 (433.125MHz)
GOTEST        Modulate with 250Hz test tone to visualise peak FM deviation
SETPAR        Return to Parallel Frequency Selection will not work
SETPAR        Module should be power-reset to exit GOTEST command
SETSER        Go to last Serially Selected Channel 3 (433.125MHz)
/RVALUE 1300   Change Synth. R value to 1300 to get multiple of 10kHz spacing
/LOAD00 43403  which allows Ch0 N value to be changed to 43403 (434.030MHz)
/SETPAR       Go to newly set Ch0 (434.030MHz) if none of P1-P3 are pulled low
/LOAD01 43410  Change Ch1 N to 43410 (434.100MHz) with non-uniform spacing
/SETPAR       Select newly set Ch1 (434.100MHz) if only P1 is pulled low
GOCHAN 1       Serially select newly set Channel 1 (434.100MHz)
/RVALUE 520    Change R value to factory set 25kHz channel spacing
/LOAD00 17322  Change Channel 0 N value to factory set 17322 (433.050MHz)
/LOAD01 17323  Change Channel 0 N value to factory set 17323 (433.075MHz)
GOCHAN 0       Go to factory set Channel 0 frequency of 433.050MHz
SETPAR        Go to factory set Ch0 or Ch1
/LOAD00 17391  Change frequency to descending order with Ch0=434.775MHz
/LOAD01 17390  with Ch1=434.750MHz to use at 100% duty cycle
GOCHAN 1       Serially select newly set Ch1 frequency of 434.750MHz
SETMOD        Enable 1200 baud Modem. (Disables Parallel Channel Selection)

Connected 01:14:55   Auto detect   2400 8-N-1   SCROLL   CAPS   NUM   Capture...

```

**Notes:**

1. A pause of at least 50ms must be allowed between command strings (EEPROM programming time) SINGLE mode does not store the N value in EEPROM. Therefore the unit is inoperative after a power down until either another valid SINGLE command is received, or mode is changed by a GOCHAN, SETPAR or SETSER command. SINGLE mode is intended for frequency agile applications.
2. /SETPAR command should be issued at the end of channel programming to put the module back into parallel frequency select mode
3. In 458MHz band, channel 12 (458.825MHz) and channel 15 (458.900MHz) are allocated specifically for fixed alarm and radio keys/vehicle paging applications respectively and should not be used for general purpose applications.
4. User can modify the frequency table of 128 channels to any desired frequency by changing N, R values of synthesizer within  $\pm 2.5$ MHz of factory set Channel 0 frequency subject to the Radio Regulatory Band Allocation in the country of intended use.
5. All other frequency, power, analogue input gain and automatic noise squelching adjustment will be treated as custom variants of the module to be set by factory.

## Pin description of TR2M with Modem mode selected

The 'modem' mentioned is a 1200 baud RS232 semi-intelligent unit (Transmit keyed when valid serial data is present, so no separate TX control needed. Coding in the datastream also permits the receiver to ignore noise and only output valid serial data). This is a half duplex unit, so collisions between transmitted and received packets must be dealt with by the user.

Pin	Name	Function
1	MOD TX_ON	Open = normal modem operation. Low = constant TX (for test). 10k pullup to 4V
2	MOD NC	Leave open
3	MOD NC	Leave open
4	RSSI	DC level between 0.5V and 2.5V. 60dB dynamic range
5	MOD NC	Leave open
6	AF out	Modem tones or noise present
7	NC	Leave open
8	+4.4V out	Regulated DC supply. 75mA max. drain. Present if unit is powered
9	0V	Ground
10	PGM	Serial programming/configuration input at RS232 level
11	MOD TXD	RS232 data input (true). 10k pullup to 4V
12	MOD RXD	Inverted RS232 data out (to inverting buffer like MAX232)
13	MOD NC	Leave open

TR2Ms on both ends should be configured to required operating frequency using GOCHAN command before starting to use the internal 1200 baud modem, because the P1-P3 pins will be used as Modem Data pins and the modem will operate on the last serially selected channel after SETMOD command is used to enable the Modem.

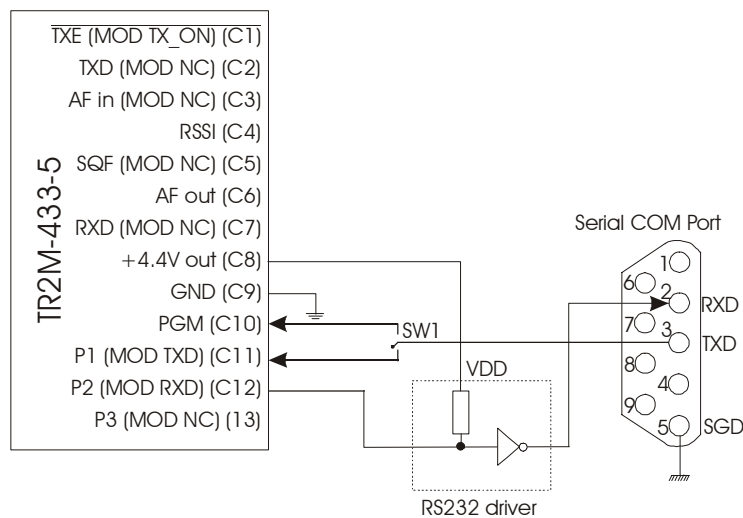

**Figure 7: TR2M interfaced to PC serial port in modem mode**

**Note:**

Baud rate used for Modem is half that of used for serial configuration. Attached RS232 devices should be set with the following:

*1200bps, 8 Data bits, No Parity, 1/2 stop bits, no flow control*

TXD (Pin 3) of a Serial Port can be switched from PGM (Pin C10) to MOD TXD (Pin C11) with no RS232 driver in between. However, MOD RXD (Pin C12) requires an RS232 line driver before it can be connected to RXD (pin 2) of a serial port. Some of the RS232 line drivers can be powered from the regulated +4.4V out (Pin C8).

# Condensed specifications

<b>Frequency</b>		458.5-459.1MHz or 433-434MHz (any 3MHz band from 420-475MHz)
<i>Frequency stability</i>		+/- 1.5kHz
<i>Channel spacing</i>		25kHz (12.5kHz by special order)
<i>Number of channels</i>		128 channels controlled via RS232 interface (8 parallel selected)
<b>Supply</b>	<i>voltage</i>	4.5-16V
	<i>Current</i>	110mA nominal transmit 27mA receive
<b>Operating temperature</b>		-10 to +60 °C (Storage -30 to +70 °C)
<b>Size</b>		59 x 38 x 10 mm
<b>Spurious radiations</b>		Compliant with ETSI EN 300 220-3 and EN 301 489-3
<b>Interface</b>		
	<i>user</i>	13pin 0.1" pitch molex
	<i>Power</i>	2pin 0.1" pitch molex
	<i>RF</i>	3pin 0.1" pitch molex
<b>Recommended PCB hole size</b>		1.2mm (min.)
<b>Intended approval</b>		ETSI Radio standard EN 300 220-3 and EMC standard EN 301 489-3

<b>Transmitter</b>	
Output power	+20dBm (100mW) ±1dB (factory adjustable 1-100mW)
TX on switching time	50 ms
Modulation type	FM, FSK (F1D, F3D)
TX modulation bandwidth	DC – 3kHz
Adjacent channel TX power	<-37dBm (<200nW)
TX spuri	better than -40dBm
Inputs	analogue, data (CMOS/TTL compatible)
<b>Receiver</b>	
Sensitivity	-118dBm for 12 dB SINAD
<i>adjacent channel</i>	65dB
<i>-910kHz</i>	69dB
<i>½ IF</i>	>80dB
<i>image / spurious</i>	>80dB
<i>blocking</i>	86dB or better
Outputs	RSSI, carrier detect, audio, data
Power on to valid audio	28ms (no noise mute)
Power on to valid audio	45ms (with noise mute)
Power on to stable data out (50:50 mark / space)	50ms (with or without mute)

Notes: 1. The data slicer cannot be depended upon for data waveform frequencies below 250Hz

2. When RX is on and a transmitter keys up, again a 50ms period is required to stabilise data output mark/space. i.e. allow at least 50ms of preamble

## Transceiver Variants

The transceiver is available in two variants – TR2I and TR2M

The standard TR2M, in Transmit Mode, reverses the Frequency Modulating order whereby the higher modulating voltage decreases the carrier frequency and lower modulating voltage increases carrier frequency which results in non-inverting Analogue and Digital Data output on the receiver. This variant can be used for applications where data inversion will be problematic.

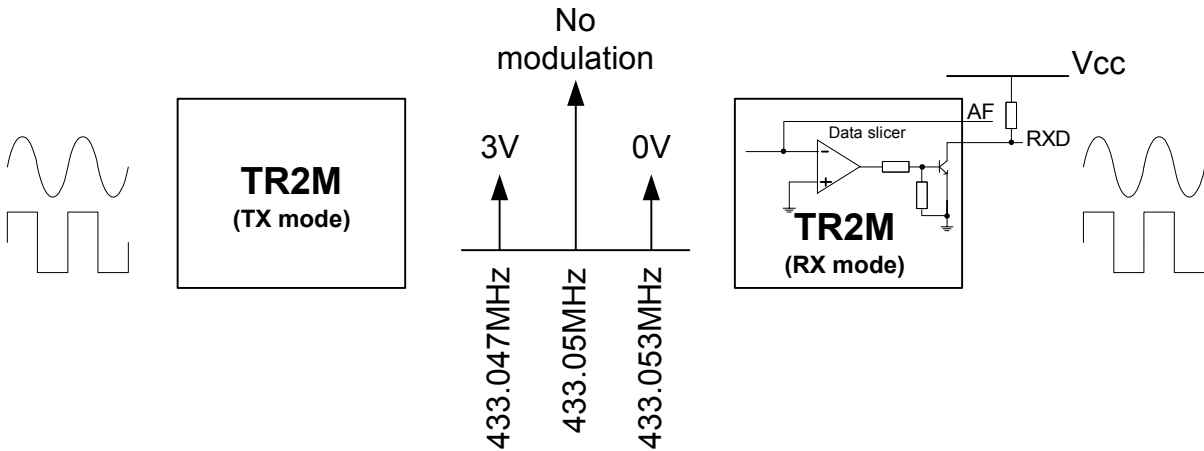

**Figure 9: Data polarity change from TR2M (in transmit mode) to TR2M (in receive mode)**

The TR2I is designed to be pin and polarity compatible with existing industry standard modules. Analogue and Digital Data Output are inverted relative to original transmitted signal in Receive Mode.

TR2I, in Transmit Mode, frequency modulates the carrier frequency in the normal sense whereby higher modulating voltage increases the carrier frequency and lower modulating voltage decreases the carrier frequency which results in an inverted Analogue and Digital Data output on the TR2I in Receive Mode. TR2I can be used as an exact plug-in replacement for existing industry standard modules.

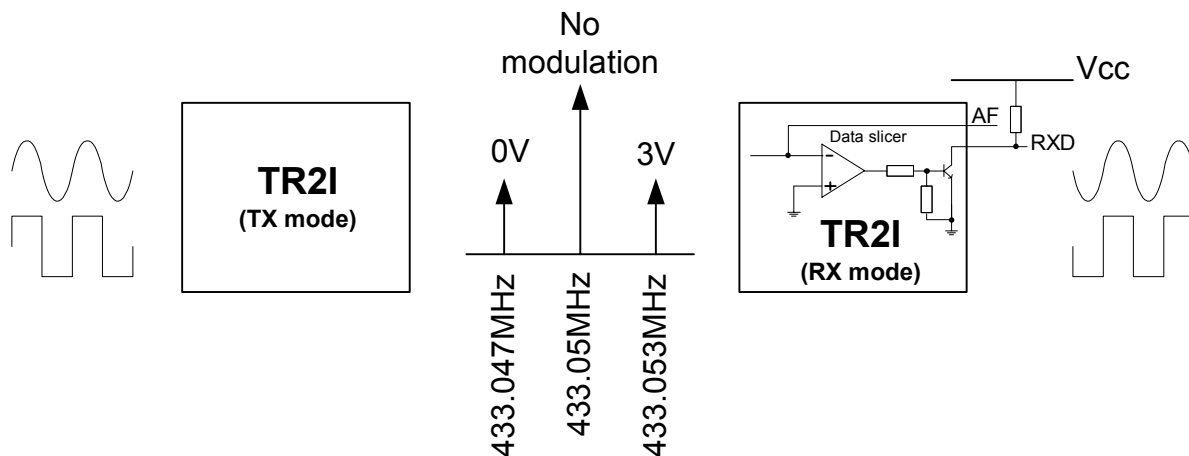

**Figure 8: Data polarity change from TR2I (in transmit mode) to TR2I (in receive mode)**

## Ordering information

Part Number	Description	Frequency band	Data rate (max)
TR2M-433-5	TX2M transceiver (non inverted received data output)	433.05MHz-434.790MHz	5kbps
TR2I-433-5	TX2I transceiver (inverted received data output)	433.05MHz-434.790MHz	5kbps
TR2M-458-5	TX2M transceiver (non inverted received data output)	458.525MHz-459.100MHz	5kbps
TR2I-458-5	TX2I transceiver (inverted received data output)	458.525MHz-459.100MHz	5kbps
TR2M-458-10	TX2M transceiver (non inverted received data output)	458.525MHz-459.100MHz	10kbps
TR2I-458-10	TX2I transceiver (inverted received data output)	458.525MHz-459.100MHz	10kbps

# **Radiometrix Ltd**

**Hartcran House  
231 Kenton Lane  
Harrow, Middlesex  
HA3 8RP  
ENGLAND**

**Tel: +44 (0) 20 8909 9595**

**Fax: +44 (0) 20 8909 2233**

**sales@radiometrix.com**

**www.radiometrix.com**

## **Copyright notice**

This product data sheet is the original work and copyrighted property of Radiometrix Ltd. Reproduction in whole or in part must give clear acknowledgement to the copyright owner.

## **Limitation of liability**

The information furnished by Radiometrix Ltd is believed to be accurate and reliable. Radiometrix Ltd reserves the right to make changes or improvements in the design, specification or manufacture of its subassembly products without notice. Radiometrix Ltd does not assume any liability arising from the application or use of any product or circuit described herein, nor for any infringements of patents or other rights of third parties which may result from the use of its products. This data sheet neither states nor implies warranty of any kind, including fitness for any particular application. These radio devices may be subject to radio interference and may not function as intended if interference is present. We do NOT recommend their use for life critical applications.

The Intrastat commodity code for all our modules is: 8542 6000

## **R&TTE Directive**

After 7 April 2001 the manufacturer can only place finished product on the market under the provisions of the R&TTE Directive. Equipment within the scope of the R&TTE Directive may demonstrate compliance to the essential requirements specified in Article 3 of the Directive, as appropriate to the particular equipment. Further details are available on The Office of Communications (Ofcom) web site:

***<http://www.ofcom.org.uk/radiocomms/ifi/>***

*Information Requests*

*Ofcom*

*Riverside House*

*2a Southwark Bridge Road*

*London SE1 9HA*

*Tel: +44 (0)845 456 3000 or 020 7981 3040*

*Fax: +44 (0)20 7783 4033*

*information.requests@ofcom.org.uk*

*European Radiocommunications Office (ERO)*

*Peblingehus*

*Nansensgade 19*

*DK 1366 Copenhagen*

*Tel. +45 33896300*

*Fax +45 33896330*

*ero@ero.dk*

*www.ero.dk*

---