

Radiometrix

Hartcran House, 231 Kenton Lane, Harrow, HA3 8RP, England

Issue 2, 15 December 2009

Tel: +44 (0) 20 8909 9595, Fax: +44 (0) 20 8909 2233

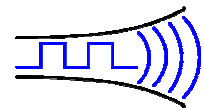

TLC2H/RLC2H

UHF Narrow Band FM Low Cost multi channel radio modules

The TLC2H transmitter RLC2H receiver modules offer a low power, reliable data link in an industry-standard pin out and footprint. This makes the TLC2H/RLC2H pair ideally suited to those low power applications where existing wideband modules have insufficient range, or where low cost multi-channel operation is needed without compromising on RF specification or regulatory requirement.



Figure 1: RLC2H receiver & TLC2H transmitter

Features

- 315, 433MHz variants conforms to EN 300 220-2 and EN 301 489-3
- High performance double superhet. PLL synthesizer with TCXO
- SAW front-end filter
- Data rates up to 5 kbps for standard module
- Usable range over 500m
- Fully screened. Low profile
- Feature-rich interface (RSSI, analogue and digital baseband)
- Re-programmable via RS232 interface
- Low power requirements

Applications

- Handheld terminals
- EPOS equipment, barcode scanners
- Data loggers
- Industrial telemetry and telecommand
- In-building environmental monitoring and control
- High-end security and fire alarms
- DGPS systems
- Vehicle data up/download
- Heavy vehicle/machinery controls

Technical Summary

- Operating frequency: 314.600-315.375MHz (USA)
433.875-434.650MHz (Europe)
458.525-458.775MHz (UK)
- Any custom frequency on 433MHz – 435MHz
- 32 channels in 315MHz, 433MHz band
- Transmit power: +10dBm (10mW)
- Supply range: 3.1 - 15V (Transmit), 3.7 – 15V(Receive)
- Current consumption: 34mA (transmit), 18mA (receive)
- Data bit rate: 5kbps max. (standard module)
- Receiver sensitivity: -120dBm (for 12 dB SINAD)
- Serial configuration by inverted RS232 at 3V CMOS level

TLC2H 433

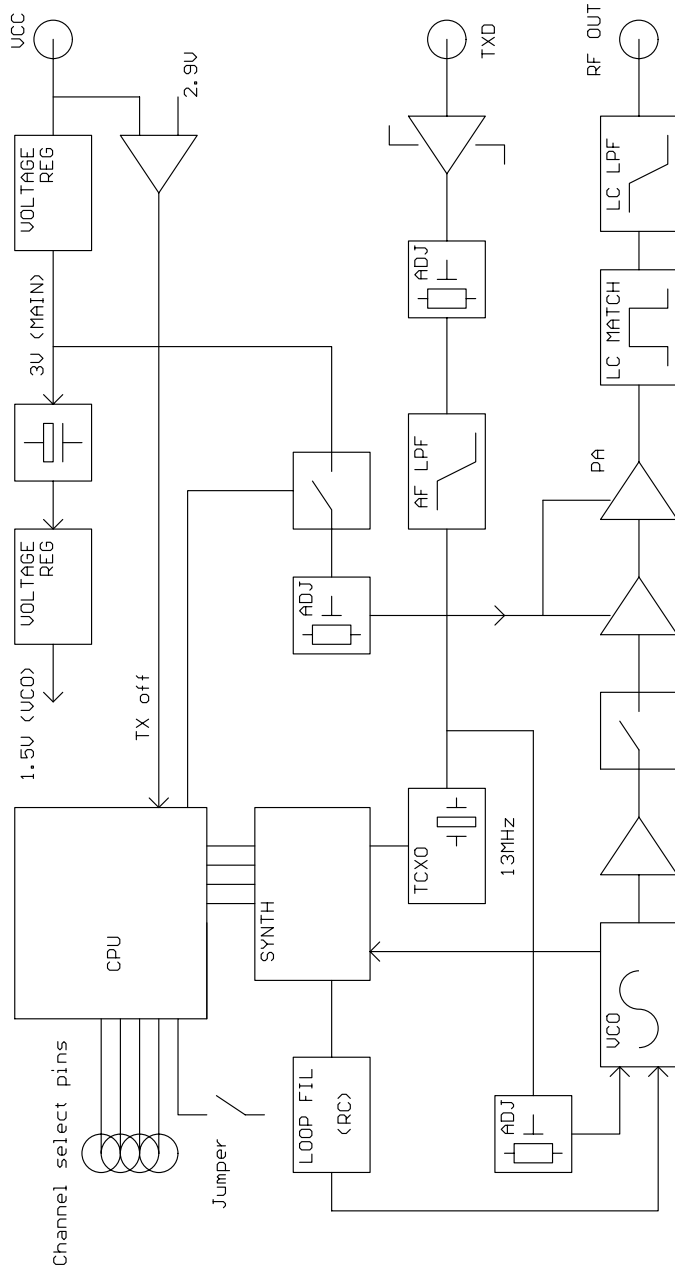

Figure 2: TLC2H block diagram

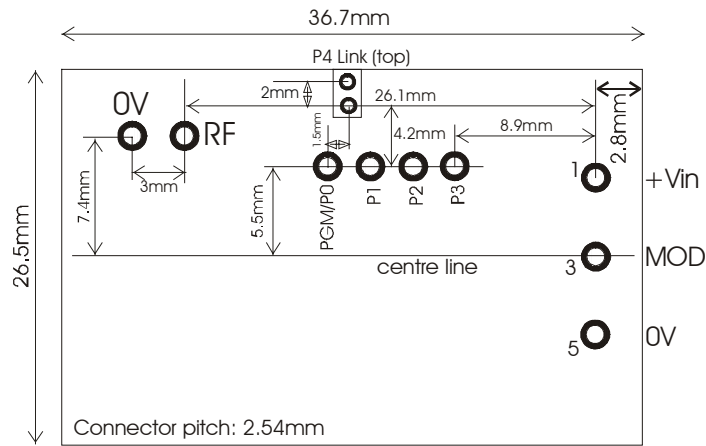

Figure 3: TLC2H footprint (top view)

Pin description – TLC2H

Pin	Name	Function
1	Vcc	3.1 – 15V DC power supply
2	No pin	Not present in TLC2H
3	TXD	DC coupled input for 3V CMOS logic. $R_{in}=47k\Omega$
4	No pin	Not present in TLC2H
5	0V	Ground
P0/PGM	Parallel channel select LSB, bit 0	True logic (0V = low). Weak pullup to 3V; Serial frequency programming / configuration ¹
P1	Parallel channel select, bit 1	True logic (0V = low). Weak pullup to 3V
P2	Parallel channel select, bit 2	True logic (0V = low). Weak pullup to 3V
P3	Parallel channel select, bit 3	True logic (0V = low). Weak pullup to 3V
P4 Jumper	Parallel channel select MSB, bit 4	Jumper inserted, P4=0 (Channel 00 – Channel 15 at 50kHz step) Jumper clear, P4=1 (Channel 16 – Channel 31 at 50kHz step)

Notes:

1. Serial programming is by an inverted, CMOS logic level, 2400 baud RS232 datastream applied to the P0 pin.
2. Parallel channel select is by 4 pin parallel input (LSB selected by a 2mm header, accessed through a hole in the can)
3. Channel select inputs have pullups (10K) to 3V internal rail. Do not exceed 3V logic levels on this port.
4. Transmitter will shutdown if Vcc falls below about 2.9v
5. TXD: logic low < 1.3V, logic high > 1.7V. TXD maximum voltage = 10V

RLC2H 433

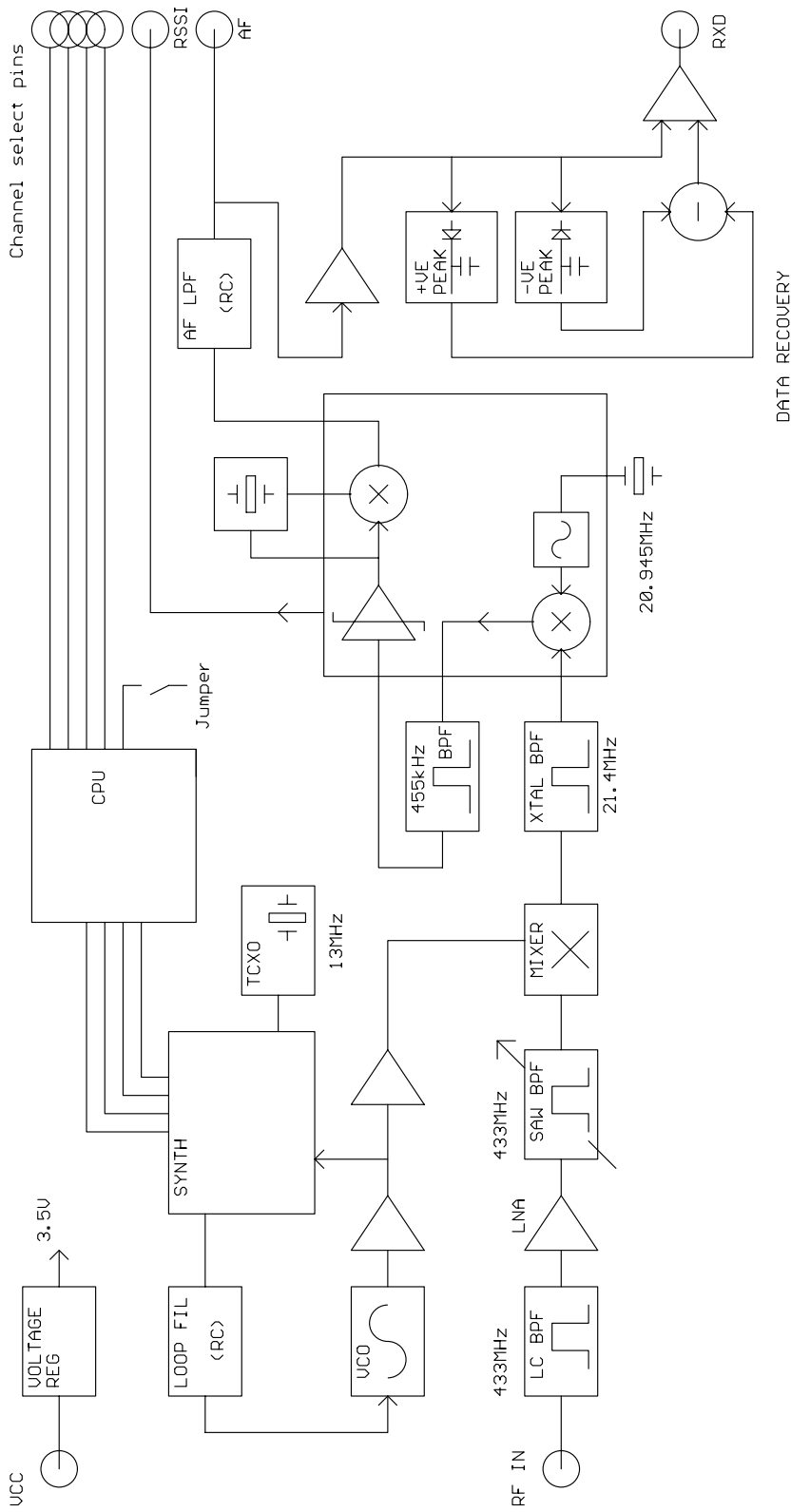

Figure 4: RLC2H block diagram

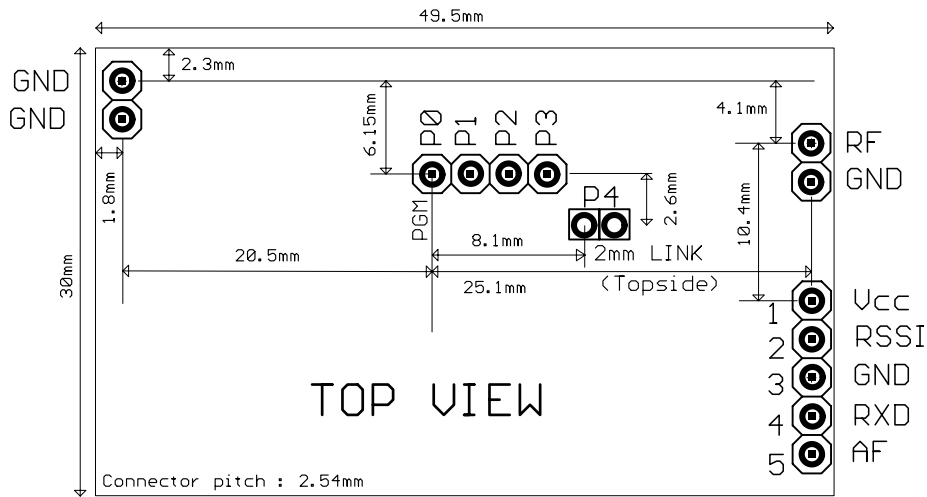

Figure 5: RLC2H footprint (top view)

Pin description – RLC2H

Pin	Name	Function
1	Vcc	DC supply (3.7V to 15V, at 18mA).
2	RSSI	0.5V-2.5V DC level. 60dB dynamic range. 40kΩ output impedance
3	0V	Ground
4	RXD	Open collector digital data output with internal 47kΩ pull-up to Vcc
5	AF	600mV _{pk-pk} audio. DC coupled, approx 0.8V bias.
P0/PGM	Parallel channel select LSB, bit 0	True logic (0V = low). Weak pullup to 3.5V Serial frequency programming / configuration ¹
P1	Parallel channel select, bit 1	True logic (0V = low). Weak pullup to 3.5V
P2	Parallel channel select, bit 2	True logic (0V = low). Weak pullup to 3.5V
P3	Parallel channel select MSB, bit 3	True logic (0V = low). Weak pullup to 3.5V
Jumper P4	Parallel channel select Jumper	Jumper inserted, P4=0 (Channel 00 – Channel 15 at 50kHz step) Jumper clear, P4=1 (Channel 16 – Channel 31 at 50kHz step)

NOTES:

1. Data recovery circuit used for RXD is not a simple 'average and compare' type. It is a peak sampling quasi-DC coupled design, allowing a greater than usual flexibility in data format. Maximum time between data transitions: 250ms
2. Serial programming is by a 2400 baud inverted 'RS232' (3V CMOS levels) datastream applied to the P0 pin. If connection to a true RS232 port is desired, then a suitable inverting level shifter / buffer (MAX232 or NPN switch transistor) is needed.
3. Parallel channel select is by a 4 pin parallel input (MSB selected by a 2mm header, accessed through a hole in the can). 3V CMOS levels should be used.
4. As supplied the frequency table is thus:

CH 00-15 314.600 – 314.975 MHz (25kHz steps) for 315MHz variant
 CH 16-31 315.000 – 315.375 MHz (25kHz steps)

CH 00-15 433.875 – 434.625 MHz (50kHz steps) for 433MHz variant
 CH 16-31 433.900 – 434.650 MHz (50kHz steps)

CH 00-15 458.525 – 458.775 MHz (25kHz steps) for 458MHz variant
 CH 16-31 458.525 – 458.775 MHz (25kHz steps)

Serial interface commands

2400 baud RS232. 8 bit data, no parity, 1 start bit, 1 or 2 stop bits.

Serial data is sent to the unit on one of the parallel channel select pins (P0). It is very important that the unit does not 'decode' switch bounce in ordinary operation as a command string, or spurious re-writing of the EEPROM will result. For this reason the user must send the 16 character string ENABLESERIALMODE to fully enable the serial command mode before sending any of the command strings listed below. Command mode is disabled on power down, or on reception of a # character.

GOCHAN aa	Serially select channel XX, where XX is 0 to 31
LOAD aa nnnnn	Set value of N register for channel aa, where aa is Channels 0 to 31
SETPAR	Channel selected by 5 bit parallel inputs (4pins + jumper)
SETSER	Channel selected by most recent GOCHAN operation
RVALUE rrrr	Set value for R register
SINGLE nnnnn	Set value of N for single channel operation. N value NOT stored in EEPROM
<cr>	Process entry
/	Clear all buffers
#	Disable command mode

aa = a two digit channel number from 00 to 31

nnnnn = synthesizer N register value (up to 65535)

rrrr = synthesizer R register value (up to 16383)

$$N_{TX} = \frac{f_{RF}}{f_{Channelspacing}} = \frac{314.600MHz}{25kHz} = 12584$$

$$N_{RX} = \frac{f_{RF} - 21.4MHz}{f_{Channelspacing}} = \frac{314.600MHz - 21.4MHz}{25kHz} = 11728$$

$$N_{TX} = \frac{f_{RF}}{f_{Channelspacing}} = \frac{433.875MHz}{25kHz} = 17355 \quad R = \frac{f_{TCXO}}{f_{channelspacing}} = \frac{13MHz}{25kHz}, \text{ So } R=520$$

$$N_{RX} = \frac{f_{RF} - 21.4MHz}{f_{Channelspacing}} = \frac{433.875MHz - 21.4MHz}{25kHz} = 16499$$

$$N_{TX} = \frac{f_{RF}}{f_{Channelspacing}} = \frac{458.525MHz}{25kHz} = 18341$$

$$N_{RX} = \frac{f_{RF} - 21.4MHz}{f_{Channelspacing}} = \frac{458.525MHz - 21.4MHz}{25kHz} = 17485$$

Note: A pause of at least 25ms must be allowed between command strings (EEPROM programming time).

SINGLE mode does not store the N value in EEPROM. Therefore the unit is inoperative after a power down until either another valid SINGLE command is received, or mode is changed by a GOCHAN, SETPAR or SETSER command. SINGLE mode is intended for frequency agile applications.

TLC2H, RLC2H channels are spaced at 50kHz interval into two frequency groups. 50kHz spacing between sequential channels minimises adjacent channel interference. P4 jumper link determines which frequency group is selected.

Channel Jumper P4 inserted	315MHz variant	433MHz variant	458MHz variant	Channel Jumper P4 removed	315MHz variant	433MHz variant	458MHz variant
0	314.600	433.875	458.525				
				16	315.000	433.900	458.525
1	314.625	433.925	458.550				
				17	315.025	433.950	458.550
2	314.650	433.975	458.575				
				18	315.050	434.000	458.575
3	314.675	434.025	458.600				
				19	315.075	434.050	458.600
4	314.700	434.075	458.625				
				20	315.100	434.100	458.625
5	314.725	434.125	458.650				
				21	315.125	434.150	458.650
6	314.750	434.175	458.675				
				22	315.150	434.200	458.675
7	314.775	434.225	458.700				
				23	315.175	434.250	458.700
8	314.800	434.275	458.725				
				24	315.200	434.300	458.725
9	314.825	434.325	458.750				
				25	315.225	434.350	458.750
10	314.850	434.375	458.775				
				26	315.250	434.400	458.775
11	314.875	434.425	458.775				
				27	315.275	434.450	458.775
12	314.900	434.475	458.775				
				28	315.300	434.500	458.775
13	314.925	434.525	458.775				
				29	315.325	434.550	458.775
14	314.950	434.575	458.775				
				30	315.350	434.600	458.775
15	314.975	434.625	458.775				
				31	315.375	434.650	458.775

Condensed specifications

Frequency	314.600-315.375MHz (USA) 433.875-434.675MHz (Europe) 458.525-458.775MHz (UK) (custom variants on 433MHz – 435MHz)
<i>Peak FM deviation</i>	±3kHz on 25kHz channel spacing variant ±1.5kHz on 12.5kHz channel spacing variant
<i>Frequency stability</i>	±1.5kHz
<i>Channel spacing</i>	25kHz or 12.5kHz
<i>Number of channels</i>	32 channels selected via RS232 interface or 2 x 16 groups by parallel port
Operating temperature	-10 °C to +60 °C (Storage -30 °C to +70 °C)
Spurious radiations	Compliant with ETSI EN 300 220-2 and EN 301 489-3

Transmitter	
Output power	+10dBm (10mW) ±1dB (1mW or 5mW by special order)
TX on switching time	50ms from power up
Modulation type	FSK (F3D)
TX modulation bandwidth	DC – 5kHz (3V CMOS compatible)
Adjacent channel TX power	<-37dBm
TX spurious	<-45dBm

Transmitter	
<i>Supply</i>	
Voltage	3.1V – 15V
Current	34mA nominal transmit
Inputs	analogue, data (CMOS/TTL compatible)
Size	37 x 27 x 8mm
Interface	<i>User</i>
	3pin 0.2" pitch molex
	<i>Channel</i>
	4pin 0.1" pitch molex
	RF
	2pin 3mm pitch
Recommended PCB hole size	1.2mm

Receiver	
Sensitivity	-120dBm for 12 dB SINAD
image / spurious / adjacent channel	<-60dB
Blocking	<-85dB
LO re-radiation	<-60dBm
<i>Supply</i>	
<i>Voltage</i>	3.7V – 15V
<i>Current</i>	18mA
Outputs	RSSI, audio, data
Size	50 x 30 x 10mm
Interface	<i>User</i>
	5pin 0.1" pitch molex
	<i>Channel</i>
	4pin 0.1" pitch molex
	RF
	2pin 0.1" pitch molex
Recommended PCB hole size	1.2mm
Power on to valid audio	28ms
Power on to stable data out (50:50 mark / space)	50ms
Maximum time between data transitions	250ms

Notes:

When RX is on and a transmitter keys up, again a 50ms period is required to stabilise data output mark/space. i.e. allow at least 50ms of preamble

RX Received Signal Strength Indicator (RSSI)

The RLC2H has wide range RSSI that measures the strength of an incoming signal over a range of 60dB or more. This allows assessment of link quality and available margin and is useful when performing range tests.

The output on pin 2 of the module has a standing DC bias of up to 0.4V with no signal, rising to 2.5V at maximum indication (RF input levels of -40dBm and above). $\Delta V_{\text{min-max}}$ is typically 2V and is largely independent of standing bias variations. Output impedance is 40k Ω . Pin 2 can drive a 100 μ A meter directly, for simple monitoring.

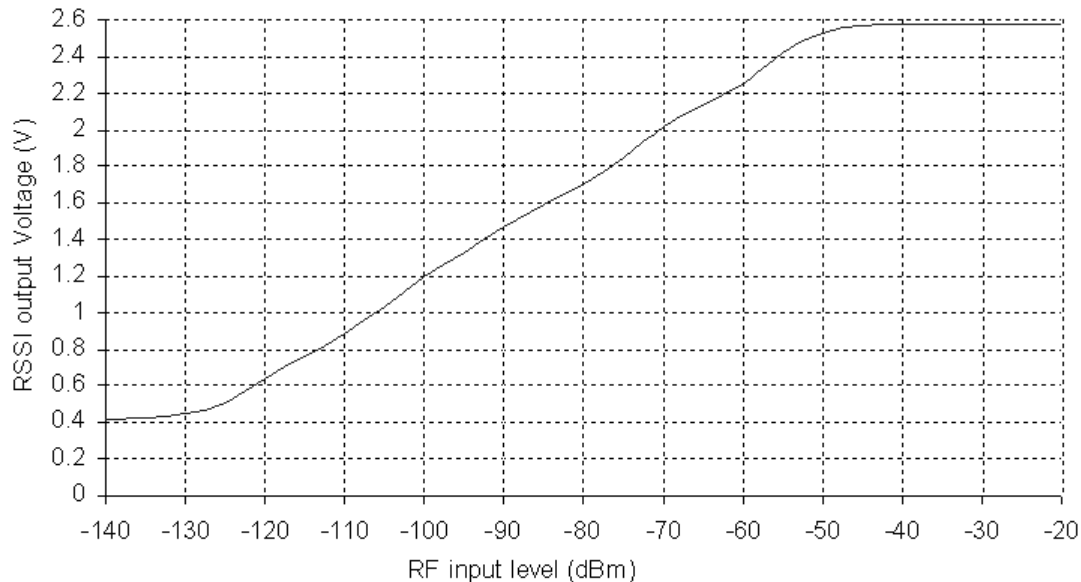

Figure 6: RSSI level with respect to received RF level at RLC2H antenna pin

Antenna requirements

Three types of integral antenna are recommended and approved for use with the module:

- A) **Whip** This is a wire, rod ,PCB track or combination connected directly to RF pin of the module. Optimum total length is 16.4cm (1/4 wave @ 433MHz). Keep the open circuit (hot) end well away from metal components to prevent serious de-tuning. Whips are ground plane sensitive and will benefit from internal 1/4 wave earthed radial(s) if the product is small and plastic cased
- B) **Helical** Wire coil, connected directly to RF pin, open circuit at other end. This antenna is very efficient given it's small size (20mm x 4mm dia.). The helical is a high Q antenna, trim the wire length or expand the coil for optimum results. The helical de-tunes badly with proximity to other conductive objects.
- C) **Loop** A loop of PCB track tuned by a fixed or variable capacitor to ground at the 'hot' end and fed from RF pin at a point 20% from the ground end. Loops have high immunity to proximity de-tuning.

	A	B	C
	<i>whip</i>	<i>helical</i>	<i>loop</i>
Ultimate performance	***	**	*
Easy of design set-up	***	**	*
Size	*	***	**
Immunity proximity effects	*	**	***
Range open ground to similar antenna	500m	200	100

The antenna choice and position directly controls the system range. Keep it clear of other metal in the system, particularly the 'hot' end. The best position by far, is sticking out the top of the product. This is often not desirable for practical/ergonomic reasons thus a compromise may need to be reached. If an internal antenna must be used, try to keep it away from other metal components, particularly large ones like transformers, batteries and PCB tracks/earth plane. The space around the antenna is as important as the antenna itself.

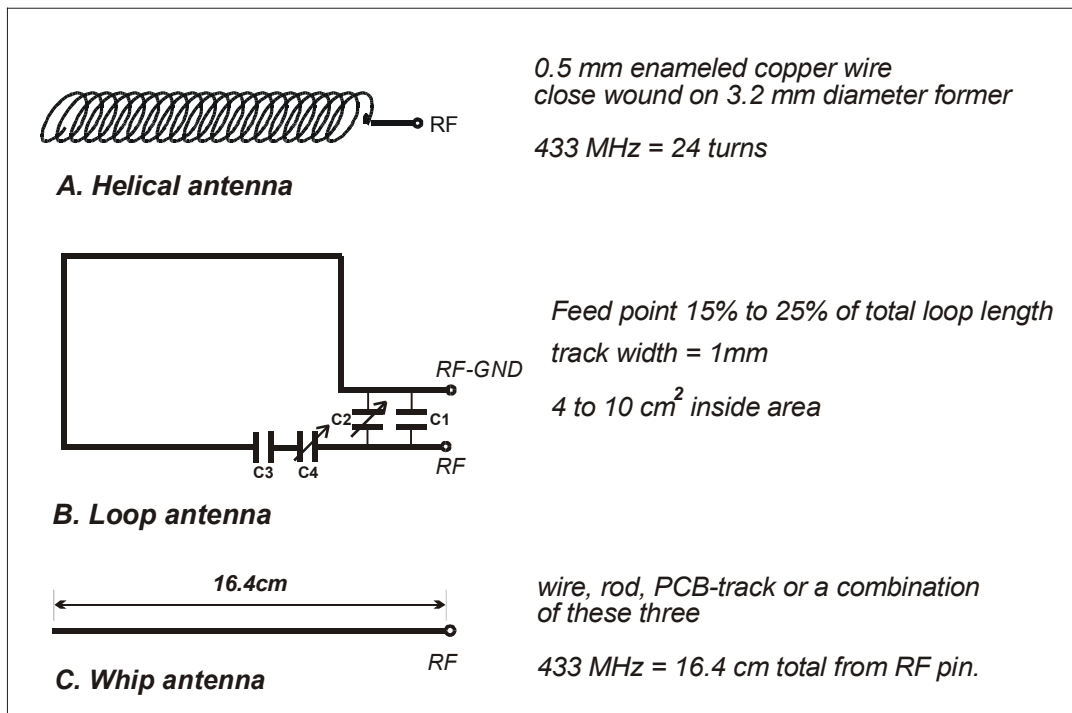

Figure 7: Antenna types

Variants and ordering information

Part No.	Description	Frequency band
TLC2H-315-5	Transmitter	314.600-315.375MHz
RLC2H-315-5	Receiver	314.600-315.375MHz
TLC2H-433-5	Transmitter	433.875-434.650MHz
RLC2H-433-5	Receiver	433.875-434.650MHz
TLC2H-458-5	Transmitter	458.525-458.775MHz
RLC2H-458-5	Receiver	458.525-458.775MHz

Other variants can be supplied to individual customer requirements at frequencies from 433MHz to 435MHz and/or optimised for specific data speeds and formats. Please consult the Sales Department for further information.

Radiometrix Ltd
Hartcran House
231 Kenton Lane
Harrow, Middlesex
HA3 8RP
ENGLAND
Tel: +44 (0) 20 8909 9595
Fax: +44 (0) 20 8909 2233
sales@radiometrix.com
www.radiometrix.com

Copyright notice

This product data sheet is the original work and copyrighted property of Radiometrix Ltd. Reproduction in whole or in part must give clear acknowledgement to the copyright owner.

Limitation of liability

The information furnished by Radiometrix Ltd is believed to be accurate and reliable. Radiometrix Ltd reserves the right to make changes or improvements in the design, specification or manufacture of its subassembly products without notice. Radiometrix Ltd does not assume any liability arising from the application or use of any product or circuit described herein, nor for any infringements of patents or other rights of third parties which may result from the use of its products. This data sheet neither states nor implies warranty of any kind, including fitness for any particular application. These radio devices may be subject to radio interference and may not function as intended if interference is present. We do NOT recommend their use for life critical applications. The Intrastat commodity code for all our modules is: 8542 6000.

R&TTE Directive

After 7 April 2001 the manufacturer can only place finished product on the market under the provisions of the R&TTE Directive. Equipment within the scope of the R&TTE Directive may demonstrate compliance to the essential requirements specified in Article 3 of the Directive, as appropriate to the particular equipment. Further details are available on The Office of Communications (Ofcom) web site:

<http://www.ofcom.org.uk/radiocomms/ifi/>

Information Requests
Ofcom
Riverside House
2a Southwark Bridge Road
London SE1 9HA
Tel: +44 (0)845 456 3000 or 020 7981 3040
Fax: +44 (0)20 7783 4033
information.requests@ofcom.org.uk

European Radiocommunications Office (ERO)
Peblingehus
Nansensgade 19
DK 1366 Copenhagen
Tel. +45 33896300
Fax +45 33896330
ero@ero.dk
www.ero.dk

Radiometrix Ltd

Worldwide Distributors

Radiometrix Ltd

Hartcran House
231 Kenton Lane
Harrow
Middlesex
HA3 8RP
ENGLAND

Tel: +44 (0) 20 8909 9595
Fax: +44 (0) 20 8909 2233
sales@radiometrix.com
www.radiometrix.com



RF Modules Australia

P.O. Box 1957, Launceston, TAS 7250
AUSTRALIA (including South Pacific)
Tel: +61 3 6331 6789, Fax +61 3 6331 1243 sales@rfmodules.com.au

RS do Brasil Ltda.

Av. Brigadeiro Faria Lima 2413 (6º andar), 01451-001
São Paulo - SP
BRAZIL
Tel: +55 11 3819 0429, Fax: +55 11 3097 0009 or 11 3815 1162
vendas@rsdobrasil.com.br

East Momiji Precision Co., Limited

Unit 1, 6/F., Heng Ngai Jewelry Centre, No. 4 Hok Yuen St. East,
Hung Hom, Kowloon/Hong Kong
CHINA
Tel: +852 28169196 Fax: +852 28162861/ 81489523
info@emomiji.com

Nu Horizons Electronics A/S

Savsvinget 7
DK-2970 Hoersholm
DENMARK
Tel: +45 7010 4888, Mobile: +45 2320 8589,
Fax: +45 7010 4889
nordic@nuhorizons.com

Lextronic

36/40 Rue du Gal de Gaulle,
94510 La Queue en Brie
FRANCE
Tél: +33 (0)1 4576 8388, Fax: +33 (0)1 4576 8141
infos@lextronic.fr

Semix Marketing & Engineering Ltd.

16 Hamelacha Street, Degem Building
Afek Industrial Park
Rosh Ha'ain
ISRAEL 48091
Tel: +972-3-9109910, Fax: +972-3-9032068
evgeni@semix.co.il

RF Design Ltd

Suite 19, 220 Ottery Road, Wynberg, Cape Town 7945
SOUTH AFRICA
Tel: +27-21-762-5365, FAX: +27-21-797-1983 sales@rfdesign.co.za

Lemos International Co. Inc.

1275 Post Rd, Suite A-12, Fairfield, Ct. 06824,
UNITED STATES OF AMERICA
Tel: +1 203 254 1531, Fax: +1 203 254 7442 sales@lemosint.com

IDVISION B.V.B.A

Augustijnenstraat 44, B-8900 Ieper
BELGIUM (including NETHERLANDS, LUXEMBOURG)
Tel.: +32 57 216141, Fax: +32 57 216434 info@idvision.net

Itronica Inc.

41 Dunvegan Crescent
Brampton, Ontario
N8X 1R6,
CANADA
Tel: +1 416 855 2106 Fax: +1 416 855 2105 info@itronica.com

Advanced Radio Telemetry

Francouzská 82, 602 00 Brn
CZECH REPUBLIC
Tel.: +420 (5)4521 1403, Fax: +420 (5)4521 0506
art@artbrno.cz

TQ Electronic Oy

Laurinkatu 40
08100 Lohja
FINLAND
Tel: +358 19 326451, Fax: +358 19 326452,
Mobile: +358 400 670 697
raimo@tqelectronic.fi

HY-LINE Communication Products GmbH

Inselkammerstraße 10,
D-82008 Unterhaching
GERMANY (including AUSTRIA)
Tel: +49 89 61450319, Fax: +49 89 6140960
communication@hy-line.de

Orvem S.p.A.

Via Sacco e Vanzetti, 34
20099 SESTO SAN GIOVANNI
Milano
ITALY
Tel: +39 02 34541160 Fax: +39 02 34541165
f.dalferro@orvem.com

HY-LINE AG

Forbühlstrasse 16, CH-8245 Feuerthalen,
SWITZERLAND
Tel: +41-52 659 63 03, Fax: +41-52 659 63 93 power@hy-line.ch