



UHF Multi Channel Hi Power Radio Modem

The TDH2 is a 9600baud half-duplex multi channel OEM radio modem with a power output of 25mW. It is a 100% pin-compatible drop-in replacement for the Radiometrix TDL2A and can be used to replace the TDL2A in applications where greater radiated power is desired. TDH2 acts as a transparent serial cable to attached host. TDH2 is an intermediate level OEM radio modem which is in between a raw FM radio module like BiM2 and a sophisticated OEM radio modem like SPM2. It takes care of preamble, synchronisation, bit balancing and error checking along with automatic noise squelching.



Figure 1: TDH2-433-9 radio modem

Provided no two devices attempt to transmit simultaneously no further restrictions on data transmission need be made, as all transmit timing, valid data identification and datastream buffering is conducted by the unit. Synchronisation and framing words in the packet prevent the receiver outputting garbage in the absence of wanted RF signal or presence of interference. For multiple radio systems (polled networks) a TDH2 can be set to 1 of 8 unique addresses. As well as having unique addresses, the TDH2 allows operation on one of 5 pre-set frequencies in the 433MHz band. These frequencies are non-overlapping and simultaneous operation of TDH2s in the same area on different channels will be possible.

Features

- Conforms to Australian/New Zealand AS/NZS 4268:2003
- High quality, stable crystal reference; Low noise synthesiser / VCO
- SAW front-end filter and multi-stage ceramic IF filtering
- Single conversion superhet
- Serial modem baud rate at 9600bps (half-duplex)
- Addressable point-to-point
- Carries ASCII and RTU MODBUS messages
- 5 serial select wideband channels
- Available as TDH2T transmitter and TDH2R receiver for one way communication

Applications

- PDAs, organisers & laptops
- Handheld / portable terminals
- EPOS equipment, barcode scanners
- In-building environmental monitoring and control
- Remote data acquisition system, data logging
- Fleet management, vehicle data acquisition

Technical Summary

- Operating frequency: 433.925MHz (default)
- Modulation: 16kbps bi-phase FSK
- Supply: 5V at 50mA transmit, 22mA receive/idle
- Transmit power: +14dBm (25mW)
- Receiver sensitivity: -105dBm (for 1% BER)
- 32 byte data buffer
- Adjacent channel rejection: 60dB @ ± 320 kHz

Evaluation platforms: TDL2A Evaluation Kit

TDL2A 433-9

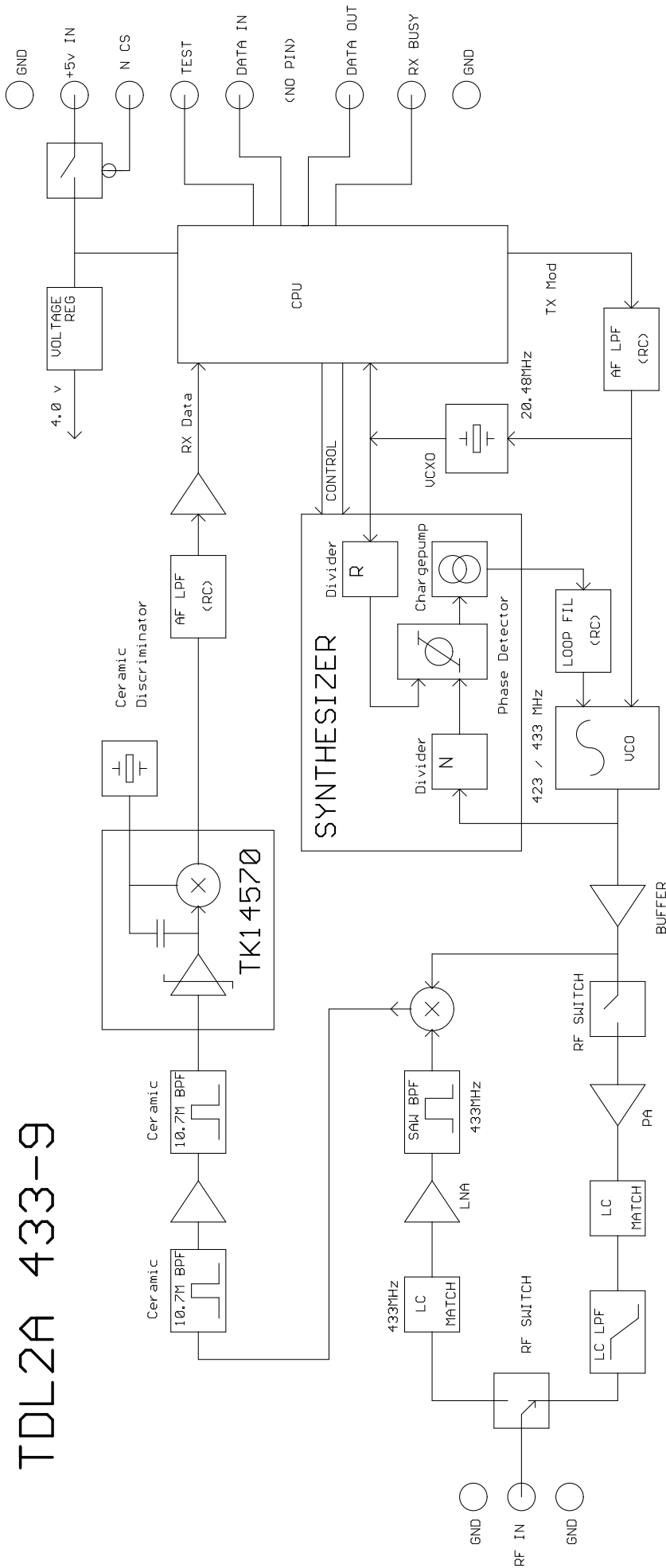

Figure 2: TDH2 block diagram

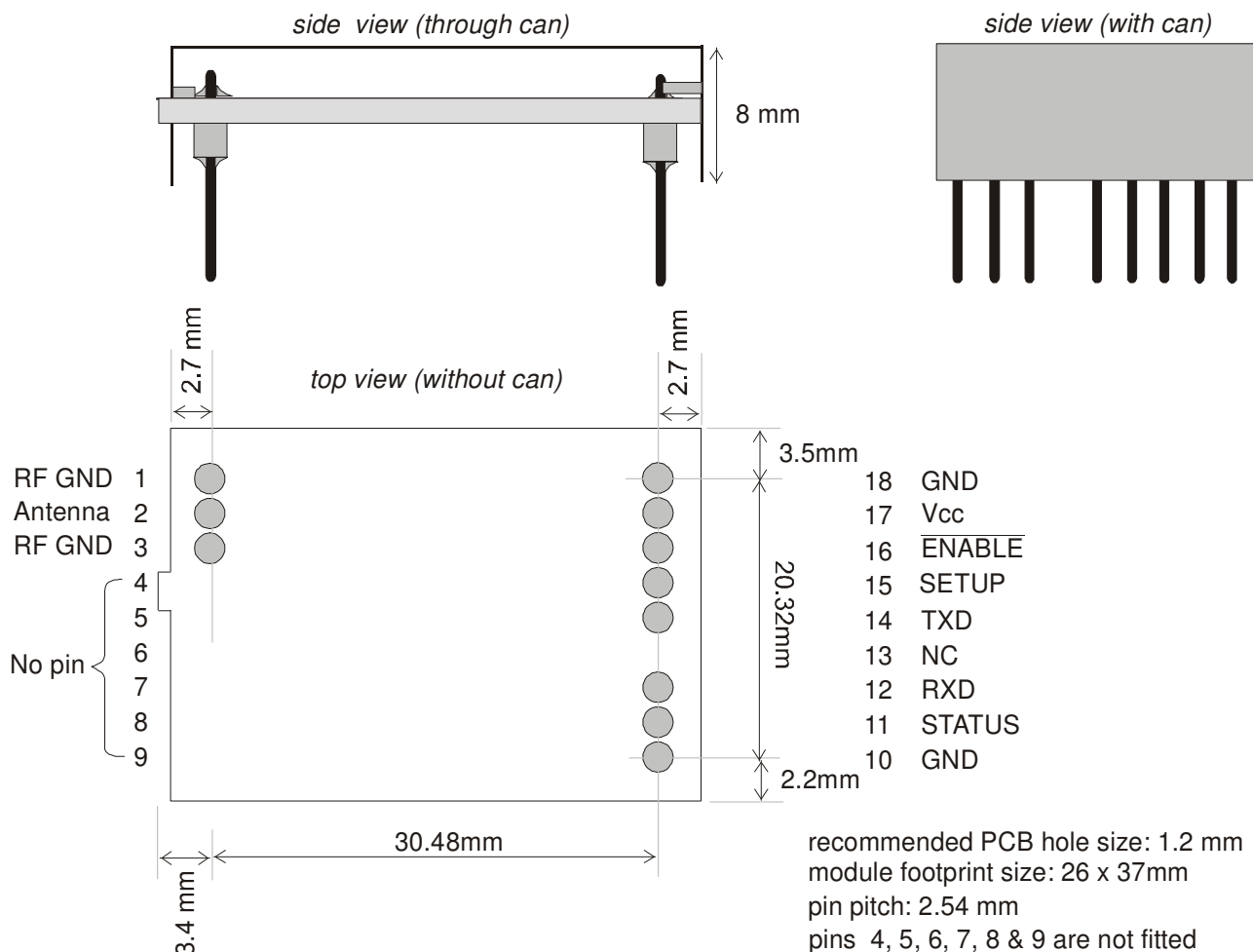

Figure 3: TDH2 footprint (top view)

Pin description

Pin	Name	Function
18	GND	Ground
17	Vcc	5V (regulated power supply)
16	ENABLE	Enable or DTR (5V CMOS logic level input)
15	SETUP	Test/Setup mode selection
14	TXD	Transmit Data (Inverted RS232 at 5V CMOS logic level)
13	NC	No Pin
12	RXD	Receive Data (Inverted RS232 at 5V CMOS logic level)
11	STATUS	Busy or CTS (5V CMOS logic level output)
10	GND	Ground

RF GND *pin 1 & 3*

RF Ground pin, internally connected to the module screen and pins 10 and 18 (0V). This pin should be connected to the RF return path (e.g. co-axial cable braid, main PCB ground plane, etc).

RF *pin 2*

50Ω RF input/output from the antenna, it is DC isolated internally. (see antenna section for details).

GND *pin 8, 9, 10 and 18*

Supply ground connection to ground plane and can.

VCC *pin 17*

5V voltage regulator should be used to have a clean 5V supply to the module. A 4V regulator is used inside for radio circuitry.

ENABLE *pin 16*

Active low Enable pin. It has a 47kΩ pull-ups to Vcc. It should be pulled Low to enable the module. This can also be connected to DTR pin (only if it is asserted by the host) of an RS232 serial port via a MAX232 or equivalent RS232-CMOS level converter.

SETUP *pin 15*

Active low input to enter configuration or diagnostic test mode. It has a 47kΩ pull-ups to Vcc

TXD *pin 14*

This is inverted RS232 data input at 5V CMOS logic level. It can be directly interfaced to data output of a UART in a microcontroller or to a TXD pin of an RS232 serial port via a MAX232 or equivalent RS232-CMOS level converter. TXD does not have an internal pull-up. If TDH2 is used in Receive only mode, TXD should be tied to Vcc.

NC *pin 13*

There is no pin in this position.

RXD *pin 12*

This is inverted RS232 data output at 5V CMOS logic level. It can be directly interfaced to data input of a UART in a microcontroller or to a RXD pin of an RS232 serial port via a MAX232 or equivalent RS232-CMOS level converter.

STATUS *pin 11*

This pin goes high when valid data is present in the receive buffer. It can be used to trigger an interrupt in the host to download received data packet instead of waiting for it. It can be also be used as a primitive CTS signal. It is inverted RS232 data output at 5V CMOS logic level. It can be directly interfaced to an input of a microcontroller as a Data Detect (DD) or to CTS, DSR, DCD pins of an RS232 serial port via a MAX232 or equivalent RS232-CMOS level converter. This is can only be used to prevent host from uploading any data before downloading already received data, because transmission is prioritised over reception and any data to be transmitted will erase received data which is in the common buffer.

Serial interface – modem operation

To connect to a true RS232 device, inverting RS232-CMOS level shifters must be used. Maxim MAX232 or equivalent are ideal, but simple NPN transistor switches with pull-ups often suffice. With typical microcontrollers and UARTs, direct connection is possible.

The Radio / data stream interface

A 32 byte software FIFO is implemented in both the transmit and receive sub-routine. At the transmitting end this is used to allow for the transmitter start up time (about 3mS), while on receiving end it buffers arriving packets to the constant output data rate. All timing and data formatting tasks are handled by the internal firmware. The user need not worry about keying the transmitter before sending data as the link is entirely transparent.

For transmission across the radio link data is formatted into packets, each comprising 3 bytes of data and a sync code. If less than 3 bytes are in the transmit end FIFO then a packet is still sent, but idle codes replaces the unused bytes. When the transmit end FIFO is completely emptied, then the transmitter is keyed off.

Operation: Radio interface.

Raw data is not fed to the radios. A coding operation in the transmit sub-routine, and decoding in the receiver, isolate the AC coupled, potentially noisy baseband radio environment from the datastream.

The radio link is fed a continuous tone by the modem. As in bi-phase codes, information is coded by varying the duration consecutive half-cycles of this tone. In our case half cycles of 62.5us and 31.25us are used. In idle (or 'preamble') state, a sequence of the longer cycles is sent (resembling an 8KHz tone).

A packet comprises the Synchronising (or address) part, followed by the Data part, made up of twelve Groups (of four half cycles duration). Each Group encodes 2 data bits, so one byte is encoded by 4 Groups.

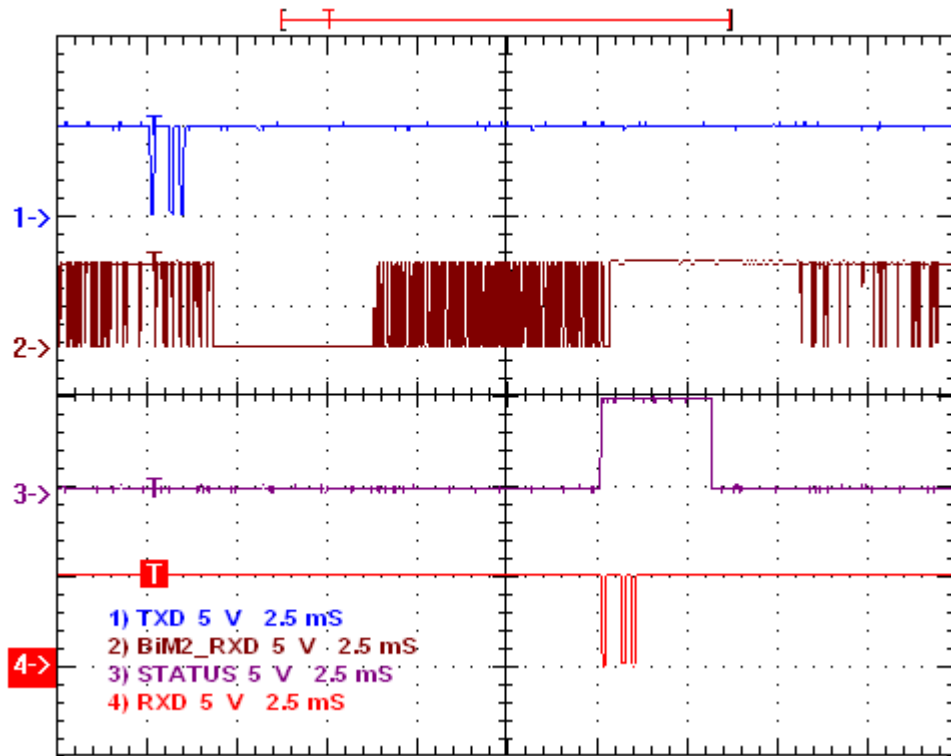

Figure 4: TDH2 transmitting and receiving

The oscilloscope screen capture shows a single byte being transmitted by TDH2. A BiM2-433-64 transceiver is used to capture the transmitted data. The character appears on the serial data output (RXD) pin of the other TDH2 after about 12.5ms. Busy (STATUS) pin is momentarily set high to indicate the presence of a valid data in the receive buffer of the TDH2.

It can be clearly seen that unlike raw radio modules, TDH2 does not output any noise when there is not any transmission. Data fed into the TXD input of a TDH2 appears at the RXD output of another TDH2 within radio range in the original form it was fed.

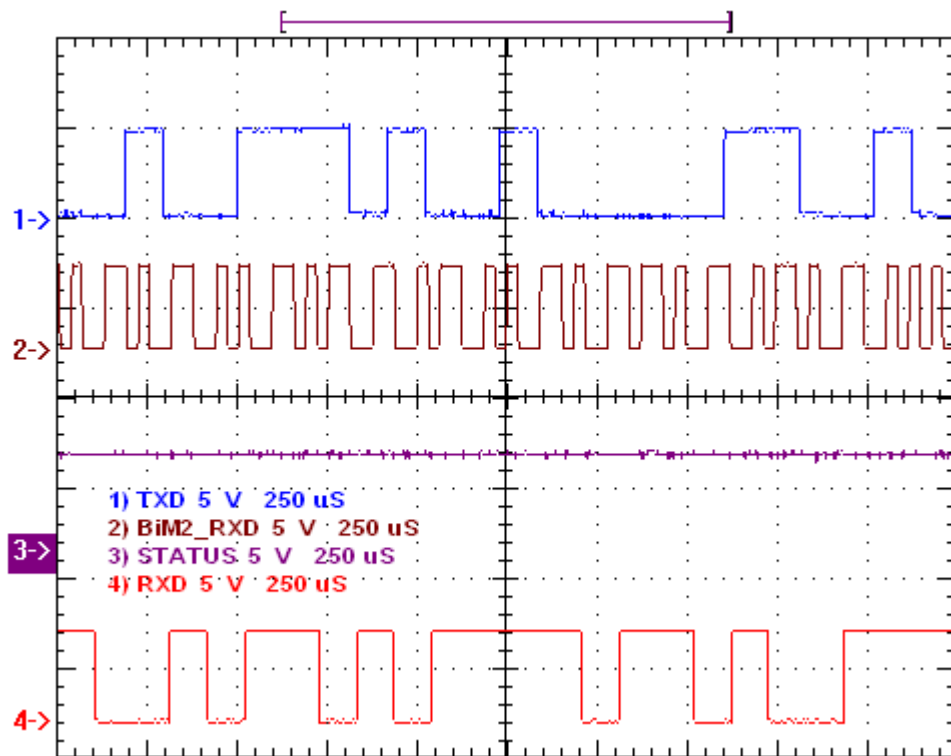

Figure 5: 16kbps Bi-phase encoded continuous data stream (expanded view)

Continuous serial data at 9600bps (above) is encoded as half-cycles of 8kHz (62.5µs long bit) and 16kHz (31.25µs short bit).

Programming the TDH2

In order to use all the functions embedded in the TDH2, the user must be aware of the setup/programming facility, which allow different addresses and frequency channels to be set up, and if necessary accesses diagnostic test modes.

The TDH2 is programmed through the same RS232 port that is used for sending/receiving data. An RS232 terminal emulator (such as Aterm or HyperTerminal) is an ideal tool.

To enter program mode, the **SETUP pin** must be **pulled low**. In this mode the radio link is disabled, but characters sent (at 9600 baud, as normal) to the unit are echoed back on the RXD pin.

The unit will only respond to certain command strings:

ADDR0 to ADDR7 <CR>: These commands set up one of 8 unique addresses.
CHAN0 to CHAN4 <CR>: These commands select one of 5 preset channels

A TDH2 will only communicate with a unit set to the same address and the same channel.

Address and channel numbers are stored in volatile memory. On power-up the TDH2 reverts to the default in EEPROM (as supplied this is always address 0 and Channel 0)

SETPROGRAM <CR>: Writes the current address and current channel into EEPROM as the new default.
 A tilde character (~, ascii 126dec) sent by the unit indicates end of EEPROM write sequence

(these commands are normally only used for factory diagnostics)

NOTONE <CR>: Transmit unmodulated carrier
LFTONE <CR>: Transmit carrier modulated with 8KHz squarewave
HFTONE <CR>: Transmit carrier modulated with 16KHz squarewave
<CR>: Transmitter off

A Carriage Return '<CR>' (00Dhex) should be entered after each command sequence to execute it.

Releasing the SETUP pin to high state returns the TDH2 to normal operation.

Interfacing a microcontroller to TDH2

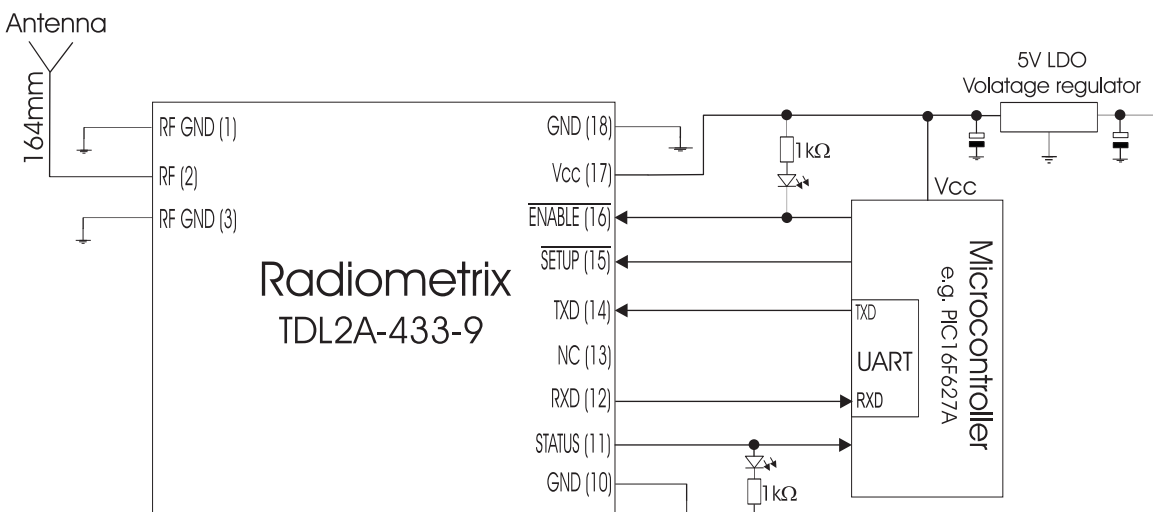

Figure 6: TDH2 interfaced directly to a microcontroller

TDH2 can be directly interfaced to any microcontrollers. If the microcontroller has a built-in UART, it can concentrate on its main task and leave the packet formatting, bit balancing and error checking of serial data to TDH2.

Serial data should be in the following format:
 1 start bit, 8 data bits, no parity, 1 or 2 stop bits
 9600bps
 0V=low, 5V=high

STATUS pin can be connected to one of the port pins which can generate an interrupt on low-to-high transition (e.g. RB0/INT pin in the PIC). This can be used to enter a receive sub-routine to download data received from remote TDH2. Therefore, the host does not need to wait in a loop for a packet.

Range test and site survey can be carried out by connecting an LED on the STATUS pin. Every time, TDH2 is within range to receive valid data, the LED will flicker.

Interfacing RS232 port to TDH2

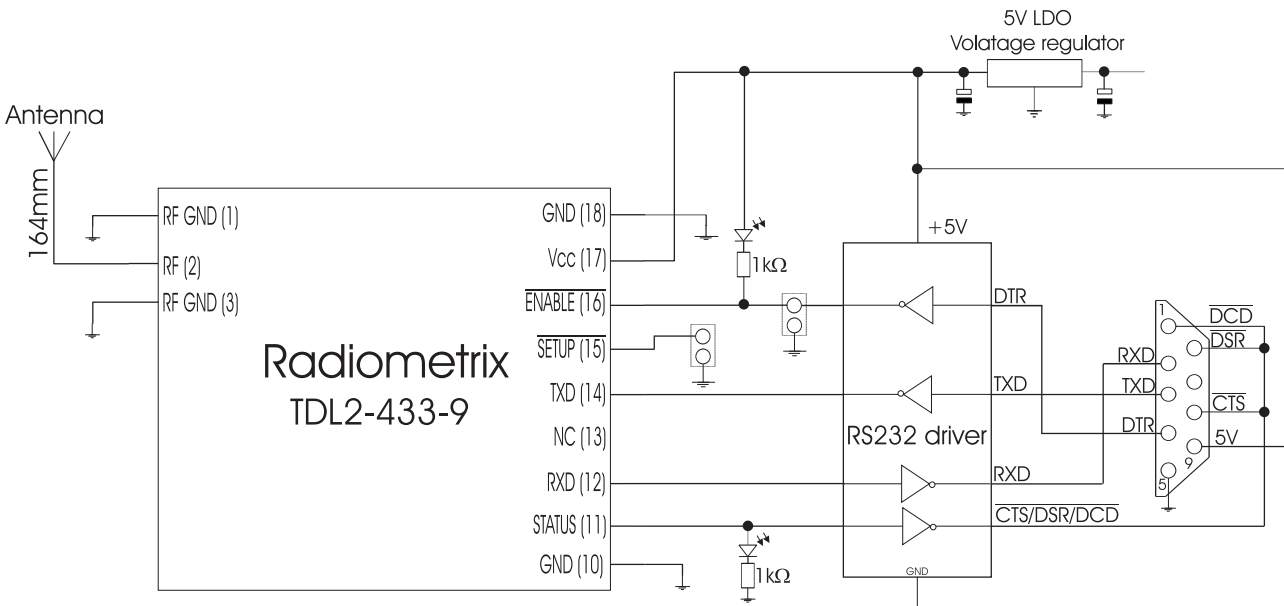

Figure 7: TDH2 interfaced to an RS232 port via an RS232 line driver/receiver

STATUS pin in this can be connected to CTS, DSR and DCD pin to simulate a flow control signal.

TDH2 is capable of continuously streaming data at 9600bps. Therefore, STATUS pin is not asserted to stop the Host from sending data as in normal RTS/CTS flow control method, but merely to warn the host that there is already data in the receive buffer which need to be downloaded before sending any more data.

Some DTE hosts assert DTR signal when they are active and this can be used via RS232 line receiver to enable TDH2. Otherwise the ENABLE must be physically pulled-low to activate the TDH2.

NOTE:

An interface board (with MAX232 type buffer, 9 way D connector, 5V voltage regulator and SMA RF connector) is available. This board is 61mm x 33mm in size.

Condensed specifications

Frequency	433.925MHz – CHAN0 (default channel)
	433.285MHz – CHAN1
	433.605MHz – CHAN2
	434.245MHz – CHAN3
	434.565MHz – CHAN4
<i>Frequency stability</i>	±10kHz
<i>Channel width</i>	320kHz
<i>Number of channels</i>	1 of 5, user programmed
Supply Voltage	5V
<i>Current</i>	50mA transmit
	22mA receive/idle
Operating temperature	-20 °C to +70 °C (Storage -30 °C to +80 °C)
Regulation	Compliant with Australian/New Zealand AS/NZS 4268:2003
Interfaces	
<i>User</i>	9pin 0.1" pitch molex
<i>RF</i>	3pin 0.1" pitch molex
Size	37 x 26 x 8mm
Transmitter	
Output power	+14dBm (25mW) ±1dB
TX on switching time	<4ms
Modulation type	16kbps bi-phase FSK
FM peak deviation	+/-22KHz
TX spurious	<-40dBm
Receiver	
Sensitivity	-105dBm for 1% BER
image	-40dB
spurious / adjacent channel	-60dB
Blocking	-80dB nominal
LO re-radiation	<-60dBm
Interface	
Data rate	9600baud, Half duplex
Format	1 start, 8 data, 1 stop, no parity
Levels	5V CMOS (inverted RS232. Mark = 5V = idle)
Buffers	32 byte FIFO
Flow control	None ('RX busy' pin provided)
Addressing	1 of 8, user programmed
Data latency	14ms (first byte into TX, to first byte out of RX)

Antenna requirements

Three types of integral antenna are recommended and approved for use with the module:

- A) **Whip** This is a wire, rod ,PCB track or combination connected directly to RF pin of the module. Optimum total length is 16cm (1/4 wave @ 433MHz). Keep the open circuit (hot) end well away from metal components to prevent serious de-tuning. Whips are ground plane sensitive and will benefit from internal 1/4 wave earthed radial(s) if the product is small and plastic cased
- B) **Helical** Wire coil, connected directly to RF pin, open circuit at other end. This antenna is very efficient given it's small size (20mm x 4mm dia.). The helical is a high Q antenna, trim the wire length or expand the coil for optimum results. The helical de-tunes badly with proximity to other conductive objects.
- C) **Loop** A loop of PCB track tuned by a fixed or variable capacitor to ground at the 'hot' end and fed from RF pin at a point 20% from the ground end. Loops have high immunity to proximity de-tuning.

Feature	A	B	C
	<i>whip</i>	<i>helical</i>	<i>loop</i>
Ultimate performance	***	**	*
Easy of design set-up	***	**	*
Size	*	***	**
Immunity proximity effects	*	**	***

The antenna choice and position directly controls the system range. Keep it clear of other metal in the system, particularly the 'hot' end. The best position by far, is sticking out the top of the product. This is often not desirable for practical/ergonomic reasons thus a compromise may need to be reached. If an internal antenna must be used, try to keep it away from other metal components, particularly large ones like transformers, batteries and PCB tracks/earth plane. The space around the antenna is as important as the antenna itself.

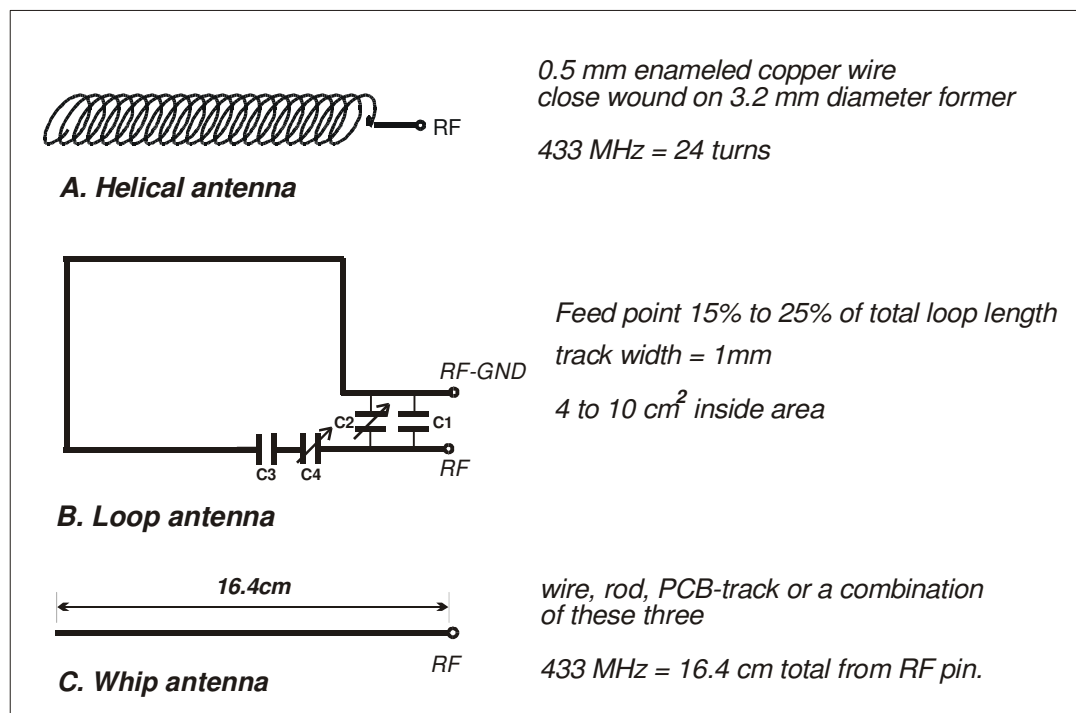

Figure 8: Antenna types

Ordering information

The TDH2 radio modem is manufactured in the following variants as standard:

For Australian general applications on 433MHz band

Part Number	Description	Frequency band	Maximum baud rate
TDH2-433-9	Half duplex modem	433.925 - 434.565 MHz	9.6kbps
TDH2T-433-9	Transmitter only	433.925 - 434.565 MHz	9.6kbps
TDH2R-433-9	Receiver only	433.925 - 434.565 MHz	9.6kbps
TDH2-433-4	Half duplex modem	433.925 - 434.565 MHz	4.8kbps
TDH2T-433-4	Transmitter only	433.925 - 434.565 MHz	4.8kbps
TDH2R-433-4	Receiver only	433.925 - 434.565 MHz	4.8kbps

Radiometrix Ltd

**Hartcran House
231 Kenton Lane
Harrow, Middlesex
HA3 8RP
ENGLAND**

**Tel: +44 (0) 20 8909 9595
Fax: +44 (0) 20 8909 2233
sales@radiometrix.com
www.radiometrix.com**

Copyright notice

This product data sheet is the original work and copyrighted property of Radiometrix Ltd. Reproduction in whole or in part must give clear acknowledgement to the copyright owner.

Limitation of liability

The information furnished by Radiometrix Ltd is believed to be accurate and reliable. Radiometrix Ltd reserves the right to make changes or improvements in the design, specification or manufacture of its subassembly products without notice. Radiometrix Ltd does not assume any liability arising from the application or use of any product or circuit described herein, nor for any infringements of patents or other rights of third parties which may result from the use of its products. This data sheet neither states nor implies warranty of any kind, including fitness for any particular application. These radio devices may be subject to radio interference and may not function as intended if interference is present. We do NOT recommend their use for life critical applications.

The Intrastat commodity code for all our modules is: 8542 6000

R&TTE Directive

After 7 April 2001 the manufacturer can only place finished product on the market under the provisions of the R&TTE Directive. Equipment within the scope of the R&TTE Directive may demonstrate compliance to the essential requirements specified in Article 3 of the Directive, as appropriate to the particular equipment.

Further details are available on The Office of Communications (Ofcom) web site:

<http://www.ofcom.org.uk/>

Information Requests

Ofcom

Riverside House

2a Southwark Bridge Road

London SE1 9HA

Tel: +44 (0)300 123 3333 or 020 7981 3040

Fax: +44 (0)20 7981 3333

information.requests@ofcom.org.uk

European Communications Office (ECO)

Pebblinghus

Nansensgade 19

DK 1366 Copenhagen

Tel. +45 33896300

Fax +45 33896330

ero@ero.dk

www.ero.dk
