

NEW

Radiometrix

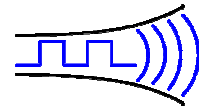

Harteran House, 231 Kenton Lane, Harrow, HA3 8RP, England

Issue 2, 09 February 2007 Tel: +44 (0) 20 8909 9595, Fax: +44 (0) 20 8909 2233

SP2-433-160

UHF SpacePort Transceiver

The SP2-433-160 is a highly integrated intelligent transceiver module, which enable a radio network/link to be simply implemented between a number of digital devices. The module combines a UHF radio transceiver and a 160kbps Fast Radio Packet controller (FRPC).



SP2-433-160

- ◆ SAW controlled FM transmitter and superhet receiver
- ◆ Reliable 50 meter in-building range, 200m open ground
- ◆ Built-in diagnostic / debug test modes
- ◆ Complies with ETSI EN 300 220-3
- ◆ Complies with ETSI EN 301 489-3
- ◆ Single 5V supply @ < 25mA
- ◆ 160kbps half duplex
- ◆ Free format packets of 1 - 60 bytes
- ◆ Packet framing and error checking are user transparent
- ◆ Collision avoidance (listen before transmit)
- ◆ Direct interface to 5V CMOS logic
- ◆ Power save mode

INTRODUCTION

The SP2 is a self-contained plug-on radio port which requires only a simple antenna, 5V supply and a byte-wide I/O port on a host microcontroller (or bi-directional PC port).

The module provides all the RF circuits and processor intensive low level packet formatting and packet recovery functions required to inter-connect an number of microcontrollers in a radio network.

A data packet of 1 to 60 bytes downloaded by a Host microcontroller into the SP2's packet buffer is transmitted by the SP2's transceiver and will "appear" in the receive buffer of all the SP2's within radio range.

A data packet received by the SP2's transceiver is decoded, stored in a packet buffer and the Host microcontroller signalled that a valid packet is waiting to be uploaded.

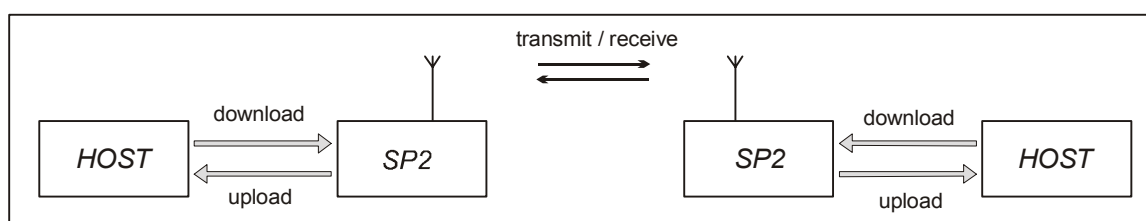

figure 1: SP2 + Host μ -controller

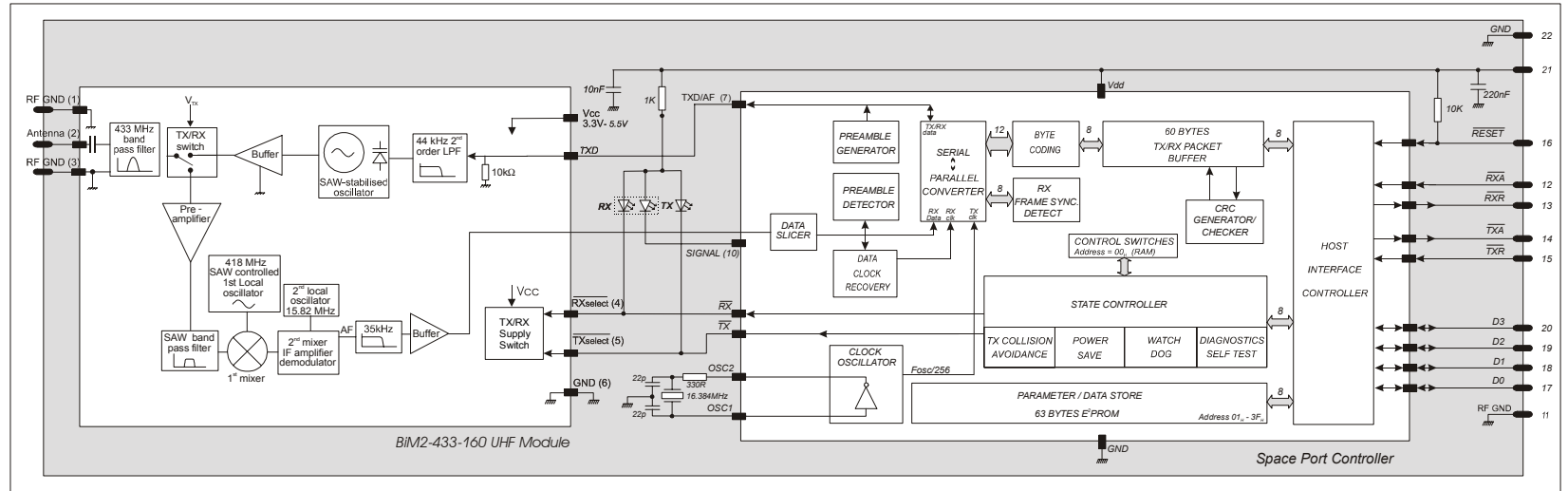

figure 2: SP2-433-160 block diagram

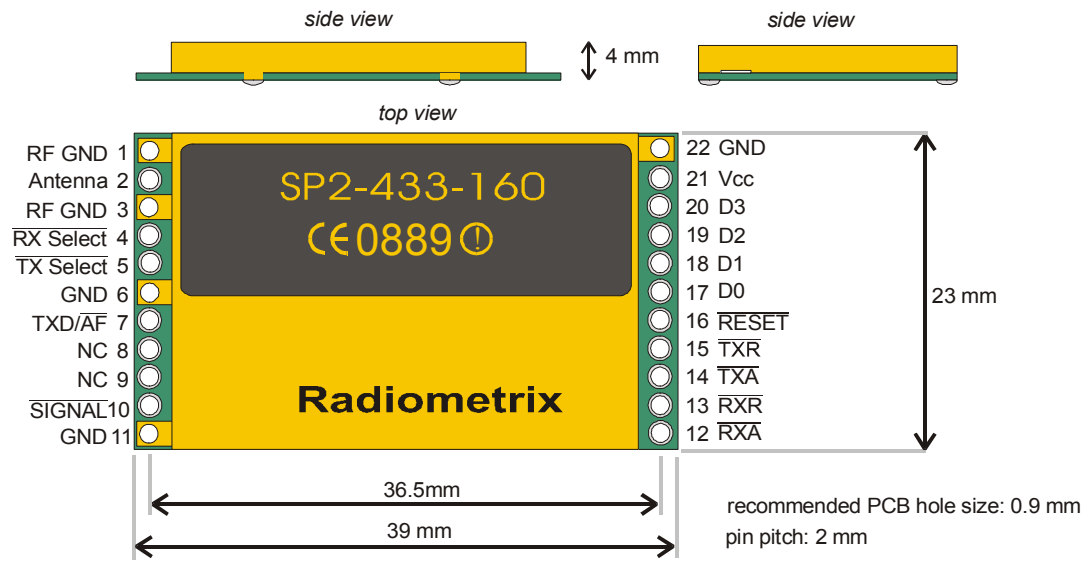

figure 3: Pin out and physical dimension

1. FUNCTIONAL DESCRIPTION

On receipt of a packet downloaded by the Host, the FSP2 will append to the packet: Preamble, start byte and a error check code. The packet is then coded for security and mark:space balance and transmitted through the BiM2 Transceiver as a 160kbps synchronous stream. One of four methods of collision avoidance (listen before TX) may be user selected.

When not in transmit mode, the SP2 continuously searches the radio noise for valid preamble. On detection of preamble, the SP2 synchronises to the in-coming data stream, decodes the data and validates the check sum. The Host is then signalled that a valid packet is waiting to be unloaded. The format of the packet is entirely of the users determination except the 1st byte (the Control Byte) which must specify the packet type (control or data) and the packet size. A valid received packet is presented back to the host in exactly the same form as it was given.

To preserve versatility, the SP2 does not generate routing information (i.e. source / destination addresses) nor does it handshake packets. These network specific functions should be performed by the host.

Additional features of the SP2 include extensive diagnostic/debug functions for evaluation and debugging of the radio and host driver software, a built in self test function and a sleep mode / wake-up mechanism which may be programmed to reduce the average current to less than 100µA. The operating parameters are fully programmable by the host and held in EEPROM, the host may also use the EEPROM as a general purpose non-volatile store for addresses , routing information etc.

1.1 OPERATING STATES

The SP2 has four normal operating states:

- *IDLE / SLEEP*
- *HOST TRANSFER*
- *TRANSMIT*
- *RECEIVE*

IDLE/SLEEP

The *IDLE* state is the quiescent/rest state of the SP2. In *IDLE* the SP2 enables the receiver and continuously searches the radio noise for message preamble. If the power saving modes have been enabled the SP2 will pulse the receiver on, check for preamble and go back to *SLEEP* if nothing is found. The 'ON' time is 2.5ms, OFF time is programmable in the SP2's EEPROM and can vary between 22ms and 181ms. The TX Request line from the Host is constantly monitored and will be acted upon if found active (low). A TX Request will immediately wake the SP2 up from *SLEEP* mode.

HOST TRANSFERS

If the host sets the TX Request line low a data transfer from the Host to the SP2 will be initiated. Similarly the SP2 will pull RX Request low when it requires to transfer data to the Host (this may polled or used to generate a Host interrupt).

The transfer protocol is fully asynchronous, i.e. the host may service another interrupt and then continue with the SP2 transfer. It is desirable that all transfers are completed quickly since the radio transceiver is disabled until the Host <> SP2 transfer is completed. Typically a fast host can transfer a 60 byte packet to / from the SP2 in under 1ms.

TRANSMIT

On receipt of a data packet from the host, the SP2 will append to the packet - preamble, frame sync byte and an error check sum. The packet is then coded for mark:space balance and transmitted. A full 60 byte packet is transmitted in 6ms of TX air time (60 data bytes @ 160kbps + 1.75ms).

Collision avoidance (Listen Before Transmit-LBT) functions can be enabled to prevent loss of packets.

Data packets may be sent with either normal or extended preamble. Extended preamble is used if the remote SP2 is in power save mode. Extended preamble length can be changed in the EEPROM memory.

RECEIVE

On detection of preamble from the radio receiver, the SP2 will phase lock, decode and error check the incoming synchronous data stream and if successful. The data is then placed in a buffer and the RX Request line is pulled low to signal to the host that a valid packet awaits to be uploaded to the Host.

An in-coming data packet is presented back to the host in the same form as it was given.

2 THE HOST INTERFACE

2.1 SIGNALS

It is recommended that the SP2 be assigned to a byte wide bi-directional I/O port on the host processor. The port must be such that the 4 data lines can be direction controlled without affecting the 4 handshake line.

<i>pin name</i>	<i>pin number</i>	<i>pin function</i>	<i>I/O</i>	<i>description</i>
<u><i>TXR</i></u>	15	TX Request	I/P	Data transfer request from HOST to SP2
<u><i>TXA</i></u>	14	TX Accept	O/P	Data accept handshake back to HOST
<u><i>RXR</i></u>	13	RX Request	O/P	Data transfer request from SP2 to HOST
<u><i>RXA</i></u>	12	RX Accept	I/P	Data accept handshake back to SP2
<i>D0</i>	17	Data 0 (4)	Bi-dir	4 bit bi-directional data bus. Tri-state between packet transfers, Driven on receipt for Accept signal until packet transfer is complete.
<i>D1</i>	18	Data 1 (5)	Bi-dir	
<i>D2</i>	19	Data 2 (6)	Bi-dir	
<i>D3</i>	20	Data 3 (7)	Bi-dir	

- notes:**
1. The 4 Handshake lines are active low
 2. The 4 Data lines true data
 3. Logic levels are 5V CMOS, see electrical specifications
 4. Input pins have a weak pull-up internally

RESET

The Reset signal, may either be driven by the host (recommended) or pulled up to Vcc via a suitable resistor (10kΩ). A reset aborts any transfers in progress and restarts the Packet Controller.

HOST DRIVEN RESET

Minimum low time: 1.0 μs, after reset is released (returned high). The host should allow a delay 1ms after reset for the SP2 to initialise itself

During this delay the host must hold TXR high (unless *DIAGNOSTIC MODES* are required) and RXR signal should be ignored.

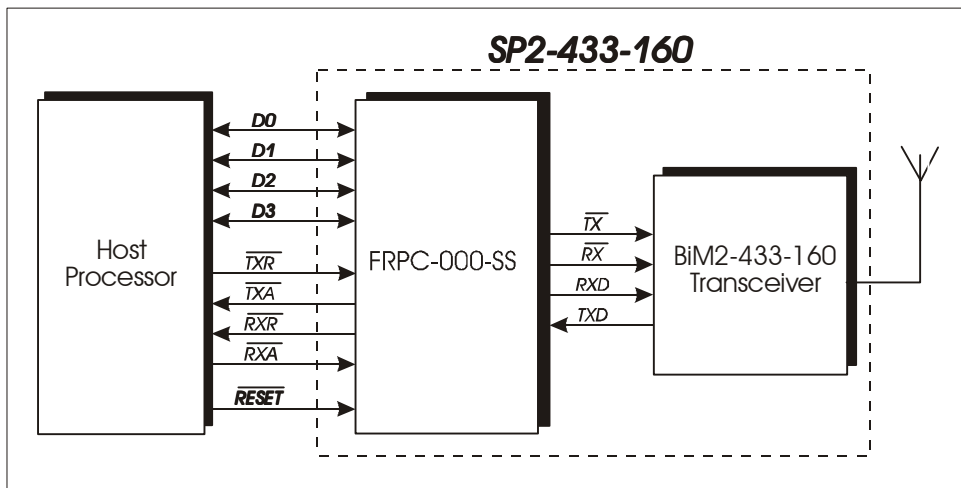

figure 4: Host to SP2 connection

2.2 HOST TO SP2 DATA TRANSFER

Data is transferred between the *SP2* and the *HOST* 4 bits (nibbles) at a time using a fully asynchronous protocol. The nibbles are always sent in pairs to form a byte, the *Least Significant Nibble* (bits 0 to 3) is transferred first, followed by the *Most Significant Nibble* (bits 4 to 7). Two pairs of handshake lines, *REQUEST* & *ACCEPT*, control the flow of data in each direction:-

TX Request & TX Accept: control the flow from the *HOST* to the *SP2* (download)
RX Request & RX Accept: control the flow from the *SP2* to the *HOST* (upload)

A packet transferred between host and *SP2* consists of between 1 and 61 bytes, the first byte of the packet is always the control byte.

There are two classes of *HOST* ↔ *SP2* transfers:

1. ***Data Packets:*** To the transmitter or from the receiver
2. ***Memory Access:*** To or from the *SP2*'s memory

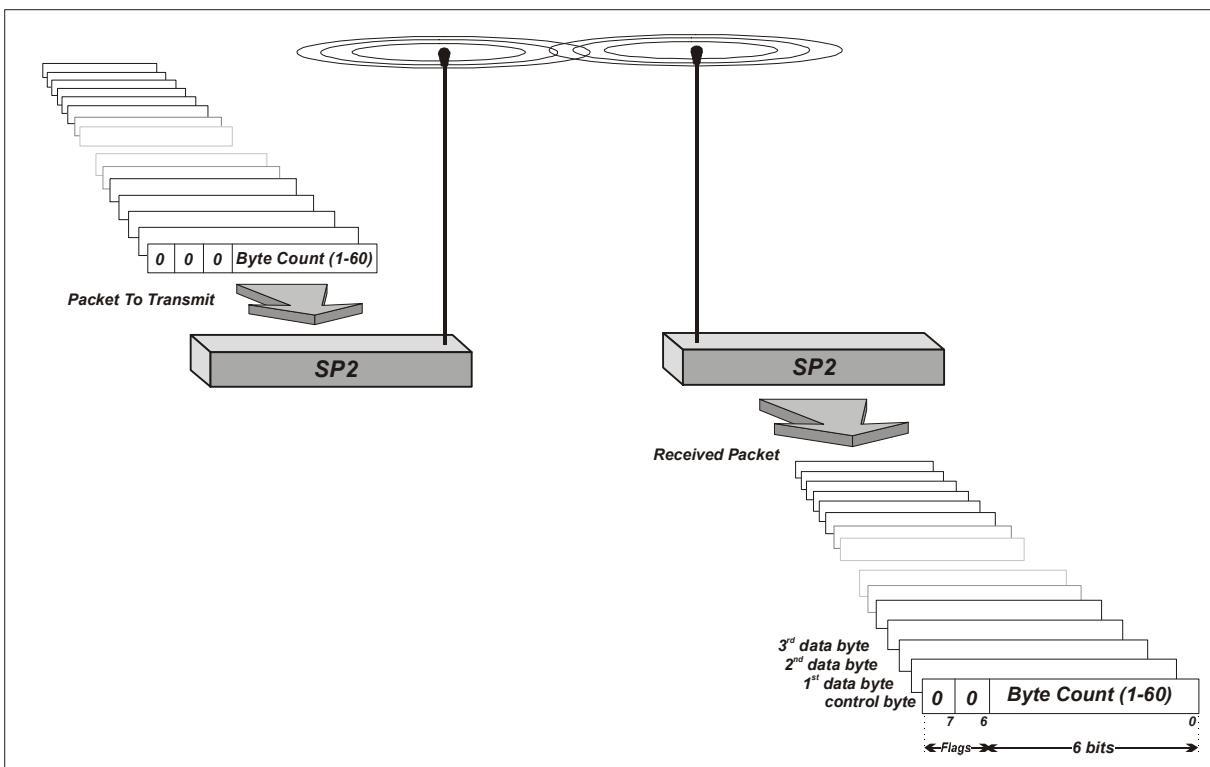

figure 5: *SP2* ↔ *Host* data transfer

2.2.1 WRITE A BYTE TO SP2

The sequence for a byte transfer from the Host to the SP2 (i.e. TX download) is asynchronous and proceeds as follows:

1. HOST asserts TX Request line low to initiate transfer
2. Wait for SP2 to pull TX Accept low (i.e. request is accepted)
3. Set data lines to output and place LS nibble on the data lines
4. Negate TX Request (set to 1) to tell SP2 that data is present.
5. Wait for SP2 to negate TX Accept (i.e. data has been accepted)

Repeat steps 1-5 with MS nibble.

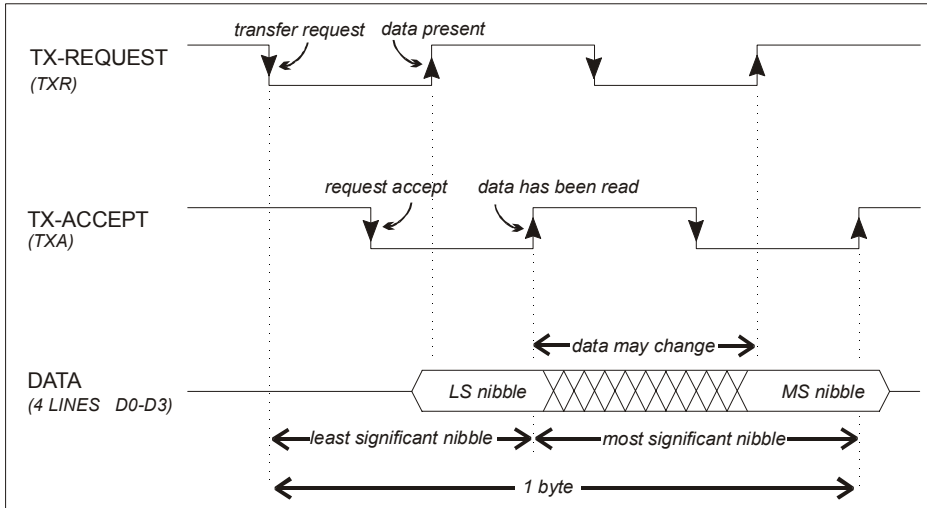

figure 6: TX download timing diagram

Notes:

- The data bus must not be set to output until step 3. i.e. after the SP2 has accepted the request. The bus may be left as an output until the entire packet has been transferred to the SP2, it should then be set back to input (default state).
- The SP2's normal response time to the initial TX Request may be up to 1ms, thereafter, for the duration of the packet, the response will be fast.
- The SP2 will ignore a TX Request from the Host while it is receiving a packet from the radio. If the incoming packet fails its error check the SP2 will respond to the TX Request as normal, i.e. the TX Accept from the SP2 will be delayed until the incoming packet has finished. If a valid packet is received this must be uploaded to the Host before the SP2 can respond to the Host's TX Request. Thus an RX Request will be signalled to the Host and not the expected TX Accept and the Host must upload the incoming packet before the TX packet can be downloaded. The TX Request should be left asserted (low) during the upload. The SP2 will respond as normal after the upload is completed.
- For the above reason it is often easier to use RX Request to trigger a HOST interrupt and upload the SP2 to the HOST under interrupt control.
- See Appendix B and C. for example SP2 driver subroutines.

2.2.2 READ A BYTE FROM THE SP2

The sequence for a byte transfer from the SP2 to the HOST (i.e. RX upload) is asynchronous and proceeds as follows :-

1. SP2 will assert RX Request line low to initiate transfer
2. Host pulls RX Accept low (i.e. request is accepted by the host)
3. SP2 will turn on it's bus drivers, place LS nibble onto data lines and negate RX Request (set to 1)
4. Host reads the data and negates RX Accept (i.e. data has been accepted)

Repeat steps 1-4 with MS nibble.

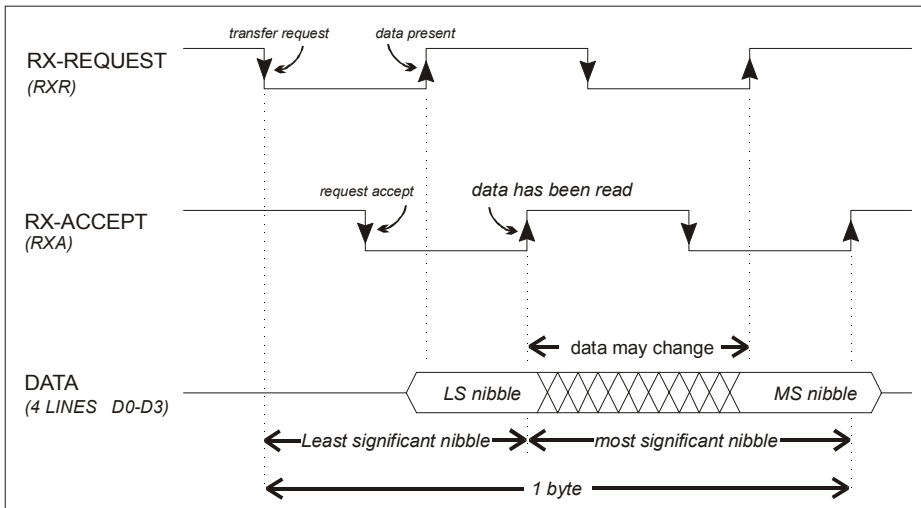

figure 7: RX upload timing diagram

Notes:

- The SP2 will turn off it's data bus drivers after the entire packet has been uploaded to the HOST.
- See Appendix B and C. for example SP2 driver subroutines.

2.3 HOST <> SP2 PACKET FORMAT

2.3.1 THE CONTROL BYTE

The first byte of a SP2 <> HOST packet transfer is always the *CONTROL BYTE*. This byte is used to control the transfer and contains information about the type of packet, number of bytes to be transferred, memory address, read/write bit etc. Bit 7 of the control byte is the Packet Type flag, PT, it determines the class of transfer and the interpretation of the other bits in the control byte.

2.3.2 SENDING AND RECEIVING DATA PACKETS

Data packets are sent to / received from remote SP2's. They begin with a control byte with bit 7 cleared and may be of variable length and contain up to 60 bytes of user determined data.

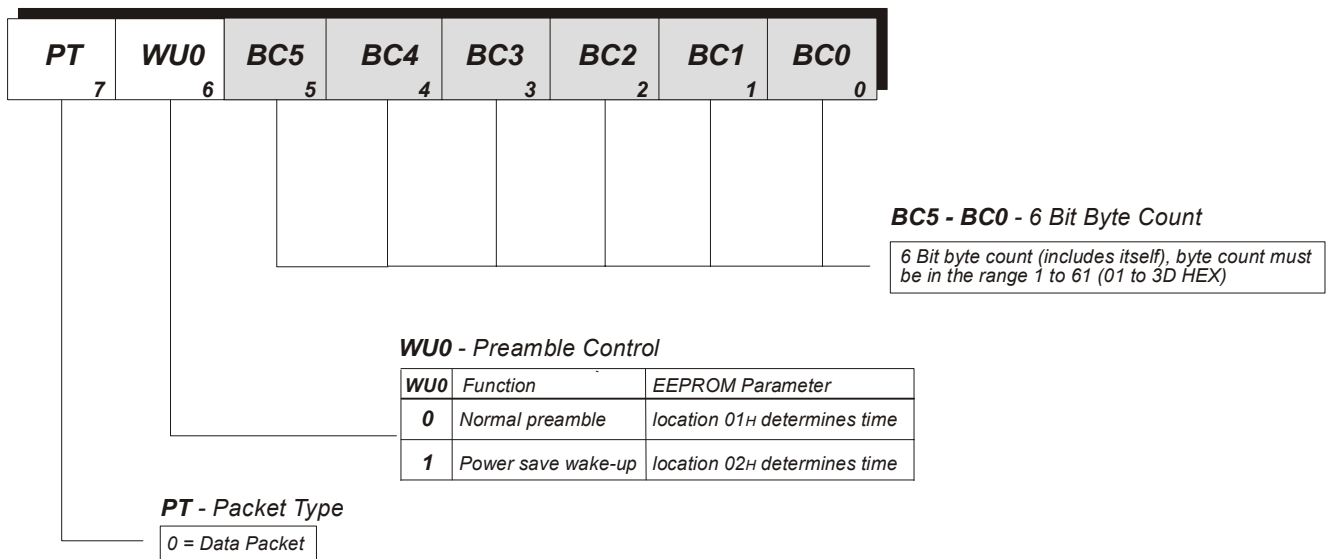

figure 8: Control byte for data packet

The remainder of the bytes in the data packet are of the users determination. The packet would usually be made up of a number of fields consisting of some but not necessarily all of the following :-

- Source address / ID
- Destination address / ID
- System ID
- Packet count
- Encryption / Scrambler control
- Additional error check codes (The SP2 performs it's own error checks)
- Routing information (for repeaters)
- Link control codes (connect/disconnect/ACK/NAK etc.)
- Data field

2.3.3 SP2 MEMORY ACCESS

The SP2's EEPROM memory can be accessed by setting bit 7 in the control byte. Bit 6 (R/W flag) defines a memory read or write. The bits left define the address.

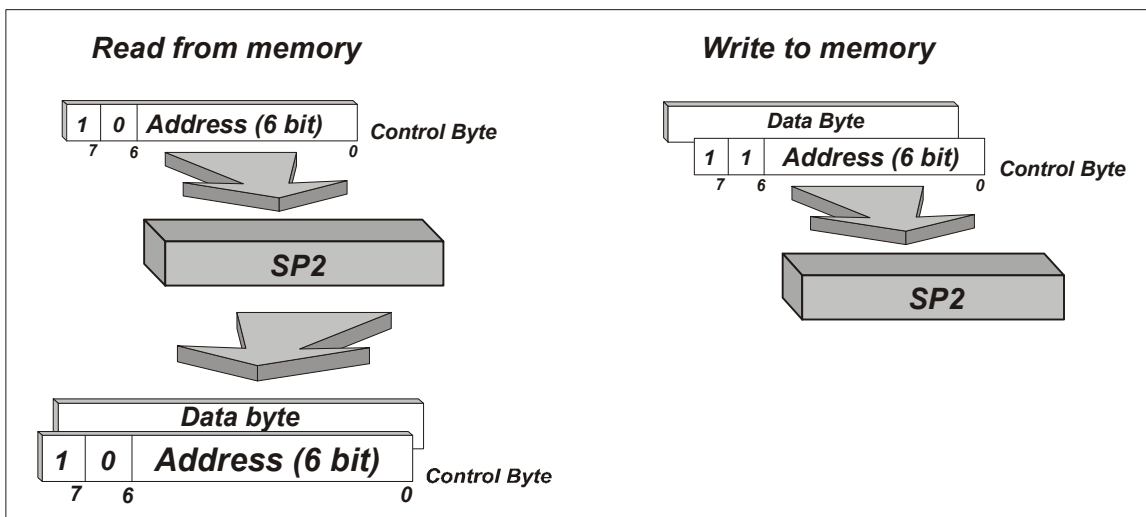

figure 9: SP2 memory access

SP2 Memory READS:

Host issues just the control byte, with bit 6 (W/R) cleared, bit 7 (PT) set and the memory address. The SP2 will respond with 2 bytes, the first is a control byte which is an echo of the control byte just issued by the host, this is useful if the host is using an interrupt handler. The 2nd byte is the memory contents.

SP2 Memory WRITES:

Host issues 2 bytes, the first is the control byte with bit 6 (W/R) set, bit 7 (PT) set and the memory address. The 2nd byte is the data to be written. The SP2 does not give a response to memory writes.

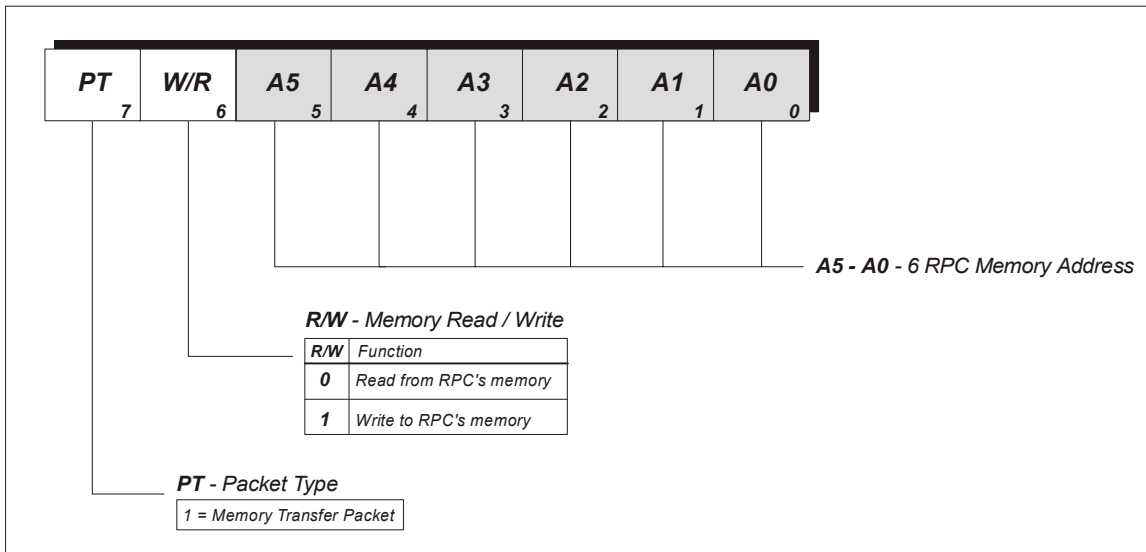

figure 10: Control byte for memory access

Notes Memory writes to locations 01 to 3F, write to the non-volatile EEPROM in the SP2. The EEPROM has a limit of 100,000 write cycles therefore its use must be restricted to infrequently changed data. The SP2 only writes to the EEPROM when instructed to by the HOST. Each byte takes 10ms to write. To prevent accidental/spurious writes to EEPROM the host must set the WE bit in SWITCHES prior to EACH byte to be written. We recommend that the host performs a read/verify after each byte write to EEPROM.

The above does not apply to any memory reads nor to writes to SWITCHES (address 00h).

3.0 SP2'S SWITCHES

SWITCHES is memory location 00h in RAM, it contains 8 flags which are used to determine the SP2's operation. On SP2 reset, power-up or watchdog Time-Out it is loaded from location 08h (in EEPROM). The default value is 00 hex - this is all functions deselected.

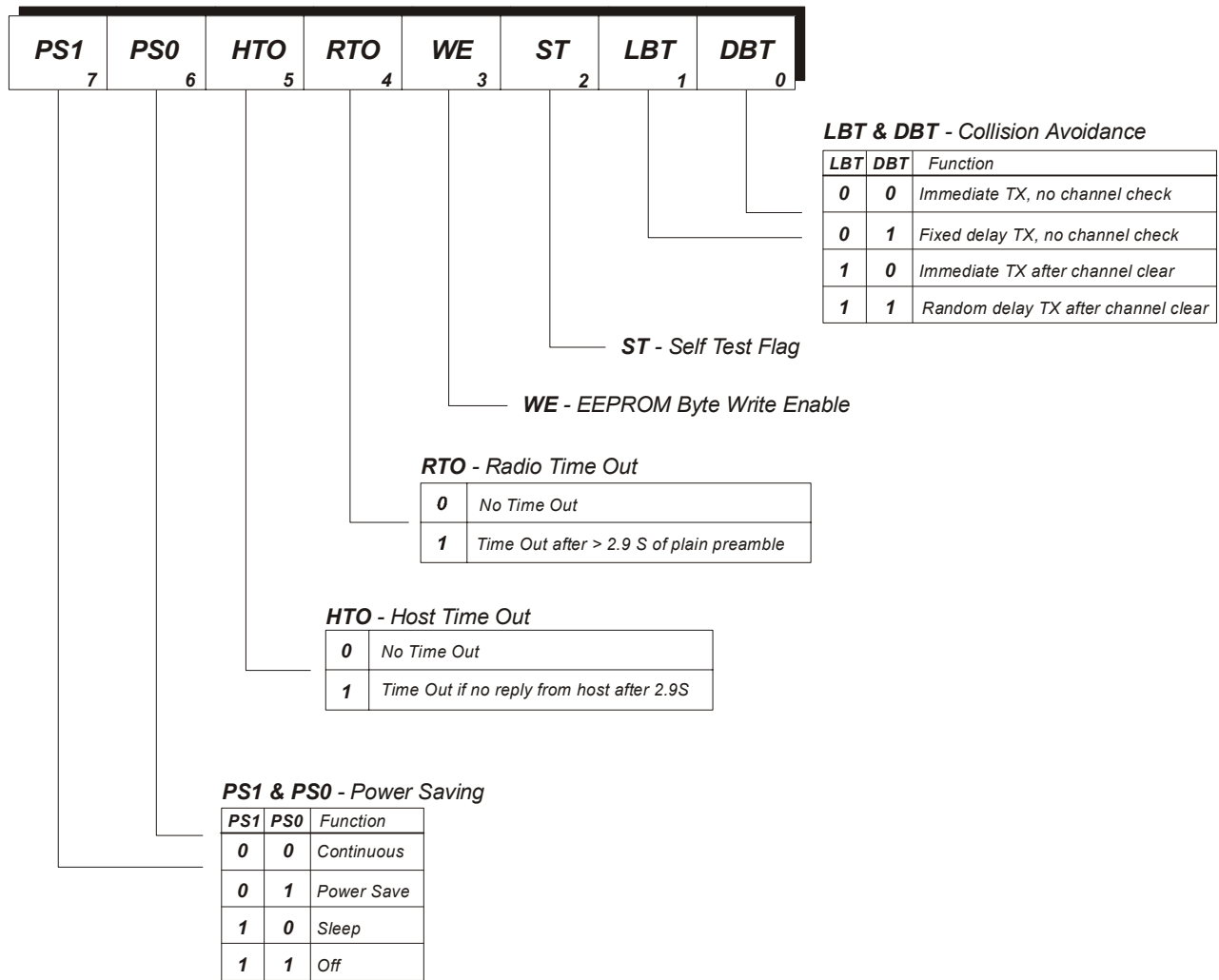

figure 11: Switches

3.1 PS0 & PS1 - POWER SAVING

The SP2 has 4 levels of power saving selected by PS0 & PS1 in SWITCHES. Power saving is achieved by shutting down the Transceiver and the SP2 for a period of time (*OFF-TIME*) when the SP2 is in the Idle state (i.e. nothing happening). During the *OFF* period current is reduced to the device leakage of <50 μ A typ. The SP2 will still respond immediately to a Host TX Request but cannot receive radio signals. After the programmed *OFF-TIME* the SP2 will wake itself up, turn the receiver on and listen for valid preamble. ON time = PWR->RX (EEPROM address 05h) + 2.5ms = 3.3ms (using SP2 Default values) If preamble is found the SP2 will stay ON and decode the packet, if not the SP2 will shut down for another OFF time period.

Also see - WAKE-UP (address 02h of EEPROM) and paragraph 2.3.2 .

<i>PS1</i>	<i>PS0</i>		
<i>0</i>	<i>0</i>	CONTINUOUS	20mA (no power saving)
<i>0</i>	<i>1</i>	POWER SAVE	programmable sleeptime *
<i>1</i>	<i>0</i>	SLEEP	< 460µA (fixed off time of 181ms)
<i>1</i>	<i>1</i>	OFF	< 50µA Transceiver is off (reset or TXR to wake-up)

* Sleeptime programmable in EEPROM address 03h.

value	off-time	Average current
<i>00</i>	22ms	2.95 mA
<i>01</i>	45ms	1.60 mA
<i>02</i>	90ms	0.85 mA
<i>03</i>	181ms	0.46 mA

The supply current's quoted above are typical for a BiM2 + SP2 using the EEPROM default values.

3.2 HTO & RTO - INTERFACE TIME-OUT

Both the Host and the Radio interfaces can 'hang' the SP2 while it waits for an external event. Under error conditions the SP2 will reset itself if the appropriate HTO or RTO switch is set.

RTO RADIO TIME OUT.

<i>0</i>	no time out
<i>1</i>	Time-Out and reset if > 2.9s of plain preamble detected. (note. valid extended preamble used for wake-ups will not cause a Time-Out to be detected)

HTO HOST TIME OUT

<i>0</i>	no time out
<i>1</i>	Time-Out and reset if Host fails to reply to any request or handshake within 2.9s

3.3 WE - EEPROM WRITE ENABLE

This bit protects the EEPROM from accidental writes, it must be set to 1 prior to each byte write to the EEPROM (addresses 01h to 3Fh). This bit will be cleared by the SP2 after each byte write.

3.4 ST - RESERVED

Do not use. Reserved for future use.

3.5 LBT & DBT - COLLISION AVOIDANCE

Listen Before Transmit, LBT, and Delay Before Transmit, DBT determine what collision avoidance the SP2 will take before each transmission.

<i>LBT</i>	<i>DBT</i>	<i>Function</i>
<i>0</i>	<i>0</i>	Immediate TX, no channel check
<i>0</i>	<i>1</i>	Fixed delay TX, no channel check (time slots) This is useful for rapid polling of up to 255 units by a master station. SLOTS is set to the units ID number, the packet size, preamble length and change over delay must be the same for all units being polled. see - EEPROM parameters
<i>1</i>	<i>0</i>	Immediate TX, if channel is clear The receiver is turned on and the channel checked for preamble or data. The SP2 will only go to transmit when the channel is clear.
<i>1</i>	<i>1</i>	Random delay TX, if channel is clear This mode is useful in random access networks where there is a high statistical probability that more than 2 SP2s could be attempting to transmit at the same time. The receiver is turned on and the channel is checked for preamble or data. If the channel is clear the SP2 will go to transmit, if the channel is busy the SP2 will delay by a random time (setable by TX-BACK-OFF in EEPROM) then try again for a clear channel.

PREAMBLE	Number of "01" preamble cycles on TX packets One '01' cycle takes 12.5µs @ 160kbit/s
address	01
default	8C
formula	Preamble time = <i>PREAMBLE</i> * 0.0125ms
valid range	01 to FF
WAKE-UP	Number of units of 'WAKE-UP PREAMBLE + PLEASE HOLD LINE' To be sent as extended preamble to wake-up a remote SP2 in power save mode. <i>WAKE-UP</i> should be set to approx. 1.5 times the remote units OFF Time
address	02
default	53
formula	Wake-up message = <i>WAKE-UP</i> * 3.24ms
valid range	01 to FF
SLEEP-TIME	Power Save 'Off' Time (RC controlled) The OFF time is controlled by an RC oscillator in the SP2 which has a wide tolerance of +/- 30%
address	03
default	03
formula	Off-time = 22 * 2 ^{<i>SLEEP-TIME</i>} ms
valid range	00 to 03
RX ↔ TX	TX ↔ RX change over delay in units of 100µs
address	04
default	2C
formula	Delay = RX ↔ TX * 12.5µs
valid range	01 to FF
PWR → RX	RX stabilisation delay in units of 100µs
address:	05
default:	8
formula:	Delay = PWR → RX * 0.1 ms
valid range:	01 to FF
TX-BACK-OFF	Maximum TX Back-off delay in units of 1ms Used when LBT=1 & DBT=1
address	06
default	03
formula	maximum delay = (2 ^{<i>TX-BACK-OFF</i>} - 1) ms
valid range	00 to 07
	00 = 0 - 1 ms 04 = 0 - 31 ms
	01 = 0 - 3 ms 05 = 0 - 63 ms
	02 = 0 - 7 ms 06 = 0 - 160 ms
	03 = 0 - 15 ms 07 = 0 - 255 ms

TX-SLOT **0 - 255 slot number for delayed (polled) TX**
 Delayed TX in packet units, used when LBT=0 & DBT=1
 address 07
 default 00
 formula delay = TX-Slot * (Preamble*0.0125 + Tpacket + 3*RX ↔ TX + 0.5) ms
 where Tpacket = (Number of bytes in packet +2) * 0.075ms
 valid range 00 to FF

RESET STATE **RESET STATE OF SWITCHES**
 The contents of this address are copied into SWITCHES on SP2 reset,
 power-up or watchdog Time-Out
 address 08
 default 00

Address 09 to 0F are reserved for future and should not be used by the HOST

EEPROM Addresses 10 TO 3F (48 BYTES) are free for HOST use as general storage.

5.0 DIAGNOSTIC / DEBUG TEST MODES

These special test modes are useful for system testing and debugging

To select these modes the SP2 should be released from reset with the TXR line held low, normal SP2 operation will resume when the TXR is set high, i.e. TXR should be held low while in these test modes.

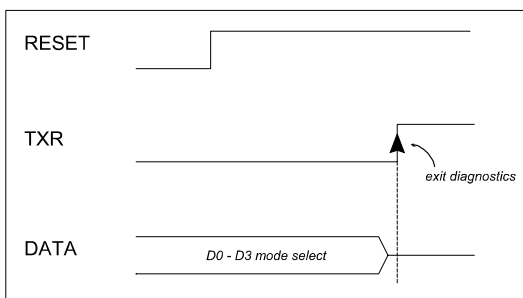

figure 13: diagnostic mode selection timing diagram

note: For normal operation of the SP2 the TXR line must be held high for either 1ms after a reset pulse or 100ms after a power up.

There are 8 test modes which are selected by a binary code applied to the SP2's data bus. A 4 bit DIL switch or rotary HEX switch connected between the data bus and 0V will select the modes (the SP2 has weak internal pull-up's). Alternatively the HOST may select the test modes by holding TXR low, resetting the SP2 and driving the required test mode code onto the data bus.

note: The SP2 continuously monitors the mode selected i.e.. a reset is not required on mode changes.

In some modes the RXR output from the SP2 is driven low to indicate 'pass' or 'OK'. An LED + 1kΩ from RXR to 5V is recommended.

Mode	Name	Function
0	RX-ON	PREAMBLE DETECTOR ON (RXR RED LED = preamble detected)
1	RX-PULSE	10ms ON : 10ms OFF, PREAMBLE DETECTOR ON RXR LED
2	TX-ON-PRE	Preamble Modulation - send continuous preamble
3	TX-ON-SQ	100Hz SQUARE WAVE MOD - TX testing on spec. Analyser
4	TX-ON-255	random 160kbit/s data for EYE DIAGRAM tests, sync's on RXR
5	TX-PULSE	PREAMBLE BURSTS (EE 01 SETTING): 10ms OFF, RX lock in tests
6	ECHO	TRANSPONDER MODE, re-transmit any valid packets received
7	RADAR	Send ASCII TEST PACKET "RADIOMETRIX" and listen for echo

Modes 6 & 7 are particularly useful for software debugging and range testing.

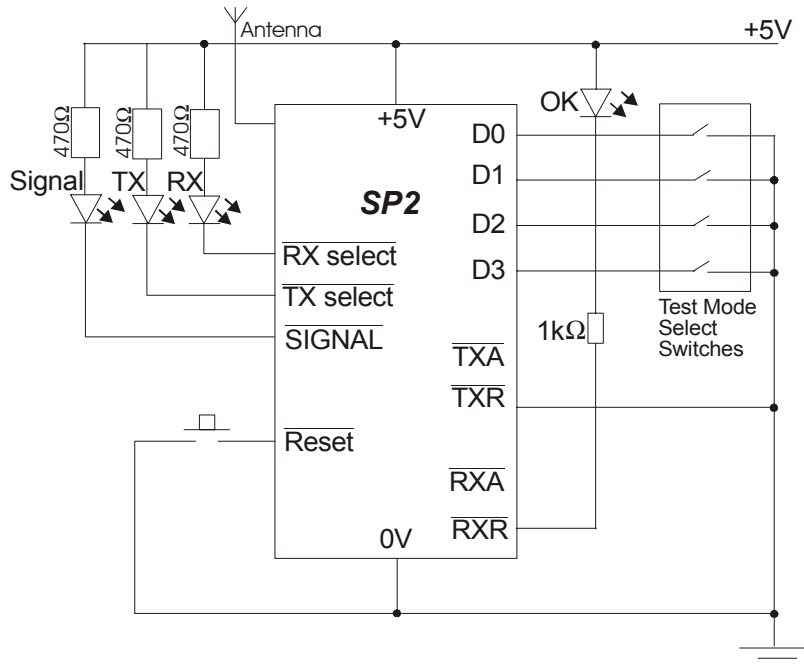

figure 14: stand-alone diagnostic mode

D3	D2	D1	D0	Mode
0	0	0	0	0
0	0	0	1	1
0	0	1	0	2
0	0	1	1	3
0	1	0	0	4
0	1	0	1	5
0	1	1	0	6
0	1	1	1	7

A Detailed look at the SP2's transceiver interface

The SP2 interfaces to the transceiver using 4 lines :-

<i>TX</i>	<i>output</i>	Active low enable for the transmitter.
<i>TXD</i>	<i>output</i>	Serial data to be sent.
<i>RX</i>	<i>output</i>	Active low enable for the receiver.
<i>RXD</i>	<i>input</i>	Received serial data.

note 1 All lines are 5V CMOS levels

note 2 There is no requirement for a carrier/signal detect signal from the transceiver nor for the RXD output to be muted when no signal is present.

The enable lines - TX & RX

These normally high, active low lines are used to control the transceiver. The SP2 is a half-duplex controller thus in normal operation the transceiver is either transmitting or receiving or off.

Transmit Data - TXD

TXD is the serial data to the transmitter, it is held low when the transmitter is not enabled. When the TX is enabled a synchronous 160kbit/s (6.25µs/bit) serial code is present to modulate the transmitter.

Receive Data - RXD

RXD is a hi-impedance input which is fed with a 'squared-up' (5V logic level) signal from the receivers' data slicer. The SP2 contains a very selective, noise immune signal detector and therefore does not require that the RXD signal be muted in the absence of signal, i.e.. squared-up channel noise may be fed to the SP2 when no signal is present.

The SP2's Packet Encoder

The packet is made-up of 4 parts:

Preamble

This is a simple 80kHz square wave, the number of cycles being programmed by address 01h of the EEPROM. The preamble has two functions, the initial portion it is used to allow the data slicer in a remote receiver to establish the correct slicing point (for the BiM2-433-160 this takes a maximum of 0.8ms), after the receiver has settled, the remaining portion is used by the receiving SP2 to positively identify and phase lock onto the incoming signal (this requires 12 cycles of preamble). The preamble may be extended to wake-up a remote SP2 in power saving mode.

Frame sync

A 7 bit Barker sequence is used to identify the start of the data. Alternatively if the transmitter is sending extended preamble (to wake a power saving remote SP2) a complimented 7 bit Barker sequence is sent every 256 preamble cycles as a 'Please Hold The Line' code. An 8th balancing bit is added after the Barker sequence.

Data

Each byte in the SP2's buffer is expanded into a 12 bit symbol prior to sending. The symbol coding has the following properties :-

- Perfect 50:50 balance, i.e.. always 6 one's & 6 zero's
- There are never more than 4 consecutive one's or zero's. This minimises the low frequency components in the code and allows fast settling times to be used for the receivers' data slicer.
- Minimum Hamming distance = 2, i.e.. each code is different from any other code by a minimum of 2 bits, thus all odd number of bit errors will always be detected.
- In general only 256 of 4096 (6.25%) possible codes are valid, i.e.. a 93.75 % probability of trapping a byte error.
- Preamble and the Frame sync codes are not part of the symbol alphabet, a 'clash' signal will cause immediate termination of the current decode followed by an attempt to lock to the new signal.

Check Sum

Since the receiver checks each symbol for integrity, a simple 8 bit check sum is used to test for overall packet integrity. This is also coded into a 12 bit symbol prior to transmission.

The SP2's Packet Decoder

Signal Decoding is in 4 stages :-

Search

Initially the SP2's decoder searches the radio noise on the RXD line for the 80kHz preamble signal. The search is performed by a 16 times over-sampling detector which computes the spectral level of 80kHz in 192 samples of the RXD signal (156µs window). If the level exceeds a pre-set threshold the decoder will attempt to decode a packet.

Lock-in

The same set of 192 samples are used to compute the phase of the incoming preamble and synchronise the internal recovery clock to an accuracy of +/- 2µs. The recovery clock samples the mid point of each incoming data bit and shifts the samples through an 8 bit serial comparator. The comparator searches the data on a bit by bit basis for the frame sync byte. While the search is in progress, the decode will abort if the preamble fails to maintain a certain level of integrity. If the comparator finds the 'please hold the line' code used during extended wake-up preamble a phase re-lock is triggered to ensure accurate phase tracking until the actual packet arrives. When the frame sync is detected the decoder attains full synchronisation and will move to the Decode state.

Decode

Data is now taken in 12 bits at a time (one symbol), decoded into the original byte and placed in the receive buffer. The symbol decoder verifies each received symbol as valid (only 256 out of a possible 4096 are valid) and will immediately abort the decode on a symbol failure. The first byte contains the byte count and is used to determine the end of message.

Check Sum

The last byte is the received check sum, this is verified against a locally generated sum of all the received bytes in the packet. If it matches the packet is valid and RXR line will be pulled low to inform the Host that a packet awaits uploading.

Notes on error handling

The SP2's decoder is deliberately non bit error tolerant, i.e.. no attempt is made to repair corrupt data bits. All of the redundancy in the code is directed towards error checking. For an FM radio link using short packet lengths, e.g. SP2 + BiM2 , packets are either 100% or so grossly corrupt as to be unrecoverable. By the same reasoning, the Host is not informed when the SP2 decoder aborts a packet decode since corrupt information is of little value. A packet acknowledge Time-Out and re-transmission is the preferred strategy for error handling.

APPENDIX - B

Example SP2 driver subroutines for Arizona PIC16C73

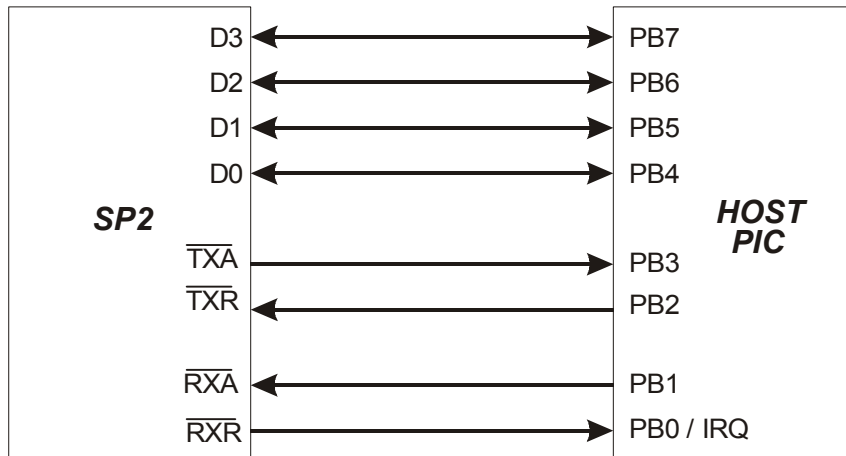

figure 15: SP2 to PIC μ-C interface

Packet transfers to / from the SP2 are best handled in the host by two subroutines :- OUT_BYTE & IN_BYTE

Additionally LISTEN_BUS is called on completion of a packet transfer to the SP2 to return the data bus to inputs (default state).

```

;-----;
;
;                               SP2 DRIVERS
;
;-----;
;
;                               HOST PROCESSOR PIC16C73 or similar
;
SP2 EQU 06 ;USE PORT B ON PIC
;
; ** Bit assignments for SP2 PORT **
;
D7 EQU 7 ;Bi-Dir
D6 EQU 6 ;Bi-Dir
D5 EQU 5 ;Bi-Dir
D4 EQU 4 ;Bi-Dir
TXA EQU 3 ;INPUT
TXR EQU 2 ;OUTPUT
RXA EQU 1 ;OUTPUT
RXR EQU 0 ;INPUT ON RB0, CAN BE CONFIGURED AS AN INTERRUPT
;
SP2_DDR EQU 86 ;Data direction register for port B (SP2)
; ;This register is in BANK 1 of the register file
;
;-----;
;
W EQU 0 ;Accumulator as Destination
F EQU 1 ;Register File as Destination
INDF EQU 00 ;INDirect File register

```

```

;SUBROUTINE IN_BYTE
;
;IN_BYTE   READ A BYTE FROM THE SP2 INTO FILE POINTED TO BY FSR
;          W IS DESTROYED
;
;          NOTE   THIS ROUTINE WILL HANG THE HOST UNTIL THE HOST
;                COMPLETES THE TRANSFER OF TWO NIBBLES
;
;                THIS SUBROUTINE CAN BE CONFIGURES TO RUN AS PART OF
;                ANINTERRUPT HANDLER IF THE :RXR LINE FROM THE SP2
;                IS USED TO TRIGGER A HOST INTERRUPT
;
;
;IN_BYTE   BTFSC SP2,RXR      ;WE GOT A RX REQUEST YET?
;          GOTO   IN-BYTE     ;NO , SO LOOP BACK AND WAIT
;
;
;                READ THE LS NIBBLE FROM THE SP2
;
;          BCF   SP2,RXA     ;ACCEPT THE REQUEST (SET ACCEPT LOW)
;
;AWAITDATA BTFSS SP2,RXR     ;HAS REQUEST GONE UP? data is present
;          GOTO  AWAITDATA   ;LOOP BACK TILL IT DOES
;
;          NOP              ;TIME DELAY TO ENSURE DATA STABLE
;                          ;BEFORE READ
;
;          MOVF   SP2,W      ;READ THE LS NIBBLE FROM THE BUS
;          BSF   SP2,RXA     ;TELL SP2 WE GOT NIBBLE (ACCEPT = 1)
;          ANDLW B'11110000' ;JUST THE DATA
;
;          MOVWF INDF        ;SAVE LS NIBBLE IN TARGET FILE (VIA
;                          ;FSR)
;          SWAPF INDF        ;RIGHT JUSTIFY LS NIBBLE
;
;                NOW GET MS NIBBLE FROM THE SP2
;
;
;INNIBBLE  BTFSC SP2,RXR     ;WE GOT NEXT RX REQUEST YET ?
;          GOTO  INNIBBLE    ;NO , SO LOOP BACK AND WAIT
;
;          BCF   SP2,RXA     ;ACCEPT REQUEST (SET ACCEPT LOW)
;
;AWAITD1   BTFSS SP2,RXR     ;HAS REQUEST GONE UP? data is present
;          GOTO  AWAITD1    ;LOOP BACK TILL IT DOES
;
;          NOP              ;TIME DELAY TO ENSURE DATA STABLE
;                          ;BEFORE READ
;
;          MOVF   SP2,W      ;READ THE MS NIBBLE FROM THE BUS
;          BSF   SP2,RXA     ;TELL SP2 WE GOT NIBBLE (ACCEPT=1)
;          ANDLW B'11110000' ;JUST THE DATA
;
;          IORWF INDF        ;COMBINE MS NIBBLE WITH LS NIBBLE
;                          ;ALREADY
;                          ;IN THE FILE (VIA FSR)RETURN
;
;          A BYTE HAS BEEN READ FROM THE SP2 INTO ADDRESS POINTED AT BY FSR
;
;-----
;

```

```

;SUBROUTINE OUT_BYTE
;OUT_BYTE WRITE A BYTE FROM FILE POINTED TO BY FSR TO SP2
;
;
; NOTE THIS ROUTINE WILL HANG THE HOST UNTIL THE SP2
; ACCEPTS THE TRANSFER OF TWO NIBBLES
;
; WARNING OUT_BYTE WILL SET THE DATA BUS TO DRIVE AFTER ;
; DETECTING A TXA FROM THE SP2.
; THE CALLING ROUTINE MUST SET 4 DATA LINES
; BACK TO I/P ON COMPLETION OF PACKET TRANSFER ;
; (i.e. call LISTENBUS)
;
OUT_BYTE SWAPF INDF,W ;GET LS NIBBLE FROM FILE (VIA FSR) INTO
; ;BITS 4 to 7 of W
; ANDLW B'11110000' ;JUST THE NIBBLE
; IORLW B'00000010' ;SET TXR LOW, LEAVE RXA HIGH
; MOVWF SP2 ;SET TXR LOW, OUTPUT NIBBLE
;
WACCEPT BTFSC SP2,TXA ;WE GOT A TX ACCEPT BACK YET?
; GOTO WACCEPT ;NO, SO LOOP BACK AND WAIT
;
;WE GOT ACCEPTANCE SO IT'S OK TO DRIVE BUS
;
; BSF STATUS,RP0 ;SELECT PAGE 1
; MOVLW B'00001001' ;DRIVE BUS
; MOVWF SP2_DDR
; BCF STATUS,RP0 ;SELECT PAGE 0 BUS IS NOW DRIVING
;
; BSF SP2,TXR ;REMOVE REQUEST, DATA IS ON BUS
WDUN BTFSS SP2,TXA ;HAS DATA BEEN READ?
; GOTO WDUN ;WAIT TILL SP2 REMOVES ACCEPT
;
;LS NIBBLE OF (FSR) IS SENT , NOW DO MS NIBBLE
;
; MOVF INDF,W ;GET MS NIBBLE FROM FILE (VIA FSR)
;
; ANDLW B'11110000' ;JUST THE MS NIBBLE
; IORLW B'00000010' ;SET TXR LOW (BIT 2), RXA STAYS HIGH
; MOVWF SP2 ;OUTPUT NIBBLE + TXR LOW
;
WACCEPT1 BTFSC SP2,TXA ;WE GOT A TX ACCEPT BACK YET?
; GOTO WACCEPT1 ;NO, SO LOOP BACK AND WAIT
;
; BSF SP2,TXR ;REMOVE REQUEST, DATA IS ON BUS
;
; BTFSS SP2,TXA ;HAS DATA BEEN READ?
WDUN1 GOTO WDUN1 ;WAIT TILL SP2 REMOVES ACCEPT
;
; RETURN
;
; BYTE IS SENT TO SP2
;-----
; SUBROUTINE - LISTEN_BUS , SET DATA BUS TO INPUT
;
LISTEN_BUS BSF STATUS,RP0 ;SELECT PAGE 1
; MOVLW B'11111001' ;BUS TO INPUT
; MOVWF SP2_DDR
; BCF STATUS,RP0 ;SELECT PAGE 0
; RETURN
;
; BUS IS LISTENING TO SP2
;-----

```

Example SP2 driver subroutines for Motorola 68HC11

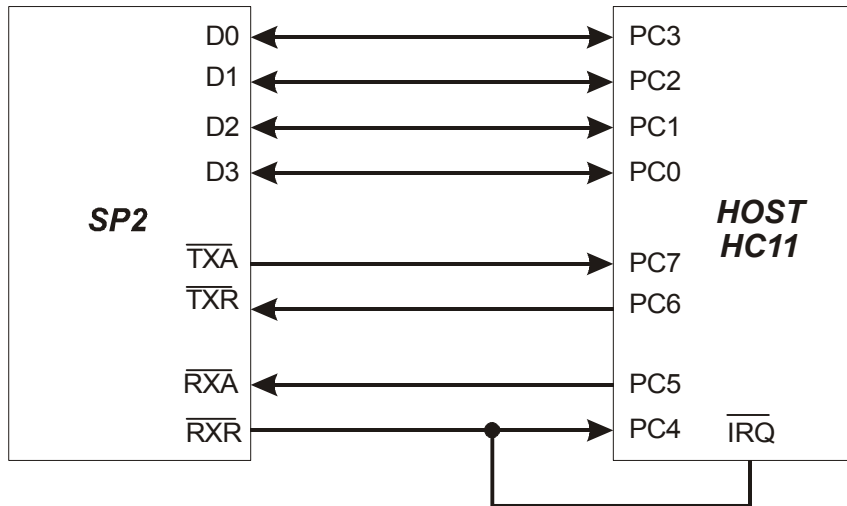

figure 16: SP2 to HC11 μ -C interface

Packet transfers to / from the SP2 are best handled in the host by two subroutines :- OUT_BYTE & IN_BYTE

Additionally LISTEN_BUS is called on completion of a packet transfer to the SP2 to return the data bus to inputs (default state).

```

*****
*
* CPU REGISTER EQUATIONS
*****
*
*This section contains a few of the necessary register equations used
*in the example subroutines.

PORTC      EQU    $1003      ;ADDRESS OF SP2 PORT
DDRC       EQU    $1007      ;DATA DIRECTION REGISTER PORT-C

* Port-C7 = RX-accept  OUTPUT
* Port-C6 = RX-request INPUT
* Port-C5 = TX-accept  INPUT
* Port-C4 = TX-request OUTPUT
* Port-C3 = SP2 data bit-3
* Port-C2 = SP2 data bit-2
* Port-C1 = SP2 data bit-1
* Port-C0 = SP2 data bit-0
    
```

```

*****
* RANDOM ACCESS MEMORY
*****
          ORG      RAM          ;RAM AREA DEFINITION

SAVE_1    RMB     1             ;TEMPORARILY SAVE LOCATION 1
SAVE_X    RMB     2             ;HOLDS FILES POINTER FOR IN_BYTE

*****
* SUBROUTINE: IN_BYTE
*****

*This subroutine is designed to be called by an interrupt handler to
*read a byte from the SP2 into a file pointed at by X
*
*Note: The interrupt handler should load the X register with the file address
before calling this subroutine.

IN_BYTE   CLR     SAVE_1        ;CLEAR TEMPORARILY MEMORY LOCATION
          LDAB   #%10010000    ;SET CORRECT DATA DIRECTION i/p
          STAB   DDRC

WAIT_RQ   LDAB   PORTC         ;WAIT FOR RX-REQUEST TO GO LOW
          BITB  #%01000000    ;
          BNE   WAIT_RQ

IN_LP     LDAB   PORTC
          ANDB  #%01111111    ;FORCE RX-ACCEPT TO GO LOW
          STAB  PORTC

WAIT_RQ1  LDAB   PORTC         ;WAIT FOR RX-REQUEST TO GO HIGH
          BITB  #%01000000
          BEQ   WAIT_RQ1

DAT_IN    LDAA   PORTC        ;READ IN DATA
          ANDA  #%00001111
          LDAB  PORTC         ;FORCE ACCEPT HIGH
          ORAB  #%10000000
          STAB  PORTC

WAIT_RQ2  STAA   SAVE_1        ;SAVE NIBBLE TO TEMP LOCATION
          LDAB  PORTC        ;WAIT FOR RX-REQUEST TO GO LOW
          BITB  #%01000000
          BNE   WAIT_RQ2

IN_LP2    LDAB  PORTC
          ANDB  #%01111111    ;FORCE RX-ACCEPT TO GO LOW
          STAB  PORTC

WAIT_RQ3  LDAB   PORTC         ;WAIT FOR RX-REQUEST TO GO HIGH
          BITB  #%01000000
          BEQ   WAIT_RQ3

DAT_IN2   LDAA   PORTC        ;READ IN DATA
          ANDA  #%00001111
          ASLA
          ASLA
          ASLA
          ASLA
          LDAB  PORTC         ;FORCE ACCEPT HIGH
          ORAB  #%10000000
          STAB  PORTC
          ORAA  SAVE_1        ;PUT NIBBLES TOGETHER IN TEMP LOCATION
          STAA  SAVE_1

READ_END  STAA   0,X          ;SAVE DATA TO POINTER ADDRESS

```

```

*****
* SUBROUTINE: OUT_BYTE
*****
*This subroutine will output of one byte to the SP2. Register X
*should contain the address of the memory location of the byte to be *send.
*Note: that register X has to be pre-loaded before entering this *
subroutine.

```

```

OUT_BYTE   LDAA   0,X           ;GET THE BYTE TO SEND TO SP2
           ANDA   #%00001111   ;PREPARE LEAST SIGNIFICANT NIBBLE
           LDAB   PORTC
           ANDB   #%11101111   ;FORCE TX-REQUEST LOW
           STAB   PORTC
WAIT_ACC   LDAB   PORTC
           BITB   #%00100000   ;WAIT FOR TX ACCEPT TO GO LOW
           BNE   WAIT_ACC
           LDAB   #%10011111   ;CHANGE DATA DDRC TO OUTPUT
           STAB   DDRC        ;TURN BUS DRIVE ON
           ORAA   #%10000000   ;MAKE SURE RXA IS HIGH
           STAA   PORTC       ;OUTPUT DATA
           LDAB   PORTC
           ORAB   #%00010000   ;FORCE TX-REQUEST HIGH
           STAB   PORTC
WAIT_REQ   LDAB   PORTC       ;WAIT FOR TX_ACCEPT TO GO HIGH
           BITB   #%00100000
           BEQ   WAIT_REQ
           LDAA   0,X         ;PREPARE MOST SIGNIFICANT NIBBLE
           LSRA                ;BY SWAPPING THE LS- & MS-NIBBLE
           LSRA
           LSRA
           LSRA
           LDAB   PORTC
           ANDB   #%11101111   ;FORCE TX-REQUEST LOW
           STAB   PORTC
WAIT_TXA1  LDAB   PORTC       ;WAIT FOR TX-ACCEPT TO GO LOW
           BITB   #%00100000
           BNE   WAIT_TXA1
           ORAA   #%10000000
           STAA   PORTC       ;OUTPUT DATA
           LDAB   PORTC
           ORAB   #%00010000   ;FORCE TX-REQUEST HIGH
           STAB   PORTC
WAIT_TXR1  LDAB   PORTC       ;WAIT FOR TX_ACCEPT TO GO HIGH
           BITB   #%00100000
           BEQ   WAIT_TXR1
           RTS

```

```

*****
* SUBROUTINE: LISTEN TO BUS
*****
*
*This will turn the SP2 host to listen mode again and should
*be called when the whole packet has been sent to the SP2
*
LISTEN_BUS LDAA   #%10010000   ;PUT PORT BACK TO LISTEN
           STAA   DDRC
           RTS
*****

```

APPENDIX - D

The FRPC as a control IC

Clock frequency

All timings within the SP2 (except sleep) are determined by the clock frequency. The standard frequency is 20.48MHz and all timings unless explicitly stated otherwise, assume this clock frequency.

$$\text{The data rate} = \frac{f_{clk}}{128} \text{ bits/s} \quad (\text{i.e. } 160\text{kbit/s for } F_{clk}=20.48\text{MHz})$$

Clock accuracy

The SP2 uses synchronous data transmission and requires an accurate reference clock. In the worst case, max. preamble and packet length, the allowable bit rate timing error between transmitter and receiver is 0.2 bits in 1000 bits, i.e. +/-200ppm total or +/-100ppm at each end.

$$\text{Bit Time} = \frac{128}{f_{xtal}} \text{ Hz} \quad \text{i.e. } 20.48\text{MHz crystal} = 6.25\mu\text{s PER BIT}$$

Accuracy, temp drifts MUST KEEP X-TAL +/- 100ppm of nominal

Radiometrix Ltd

**Hartcran House
231 Kenton Lane
Harrow, Middlesex
HA3 8RP
ENGLAND
Tel: +44 (0) 20 8909 9595
Fax: +44 (0) 20 8909 2233
sales@radiometrix.com
www.radiometrix.com**

Copyright notice

This product data sheet is the original work and copyrighted property of Radiometrix Ltd. Reproduction in whole or in part must give clear acknowledgement to the copyright owner.

Limitation of liability

The information furnished by Radiometrix Ltd is believed to be accurate and reliable. Radiometrix Ltd reserves the right to make changes or improvements in the design, specification or manufacture of its subassembly products without notice. Radiometrix Ltd does not assume any liability arising from the application or use of any product or circuit described herein, nor for any infringements of patents or other rights of third parties which may result from the use of its products. This data sheet neither states nor implies warranty of any kind, including fitness for any particular application. These radio devices may be subject to radio interference and may not function as intended if interference is present. We do NOT recommend their use for life critical applications.

The Intrastat commodity code for all our modules is: 8542 6000.

R&TTE Directive

After 7 April 2001 the manufacturer can only place finished product on the market under the provisions of the R&TTE Directive. Equipment within the scope of the R&TTE Directive may demonstrate compliance to the essential requirements specified in Article 3 of the Directive, as appropriate to the particular equipment.

*Further details are available on The Office of Communications (Ofcom) web site:
http://www.ofcom.org.uk/radiocomms/ifi/licensing/licensing_policy_manual/*

*Information Requests
Ofcom
Riverside House
2a Southwark Bridge Road
London SE1 9HA
Tel: +44 (0)845 456 3000 or 020 7981 3040
Fax: +44 (0)20 7783 4033
information.requests@ofcom.org.uk*

*European Radiocommunications Office (ERO)
Peblingehus
Nansensgade 19
DK 1366 Copenhagen
Tel. +45 33896300
Fax +45 33896330
ero@ero.dk
www.ero.dk*
