

RX1L

Issue 1, 01 August 2012

Low current Narrow Band VHF receiver

The RX1L receiver modules have very low current consumption (1mA) and it offers a reliable data link in an industry-standard pin out and footprint. This makes the RX1L ideally suited to those low power applications where existing narrow band modules are not suitable for prolonged battery powered application. Two versions on the 151.300MHz and 173.225MHz frequencies are available. RX1L is compatible with the Radiometrix TX1 and BiM1T transmitters.



Figure 1: RX1L-173.225-5 receiver

Features

- Conforms to EN 300 220-3 and EN 301 489-3
- Data rates up to 5 kbps for standard module
- Fully screened.
- Very low current consumption
- Long battery life

Applications

- Solar powered remote installation
- Data loggers
- Industrial telemetry and telecommand
- In-building environmental monitoring and control
- High-end security and fire alarms
- Vehicle data up/download

Technical Summary

- Size: 59 x 38 x 7mm
- Operating frequency: 151.300 or 173.225MHz
- Supply range: 3.1V - 9V
- Current consumption: 1mA
- Data bit rate: 5kbps max. (standard module)
- Receiver sensitivity: -120dBm (for 12 dB SINAD)

Evaluation platforms: NBEK + xx2M carrier

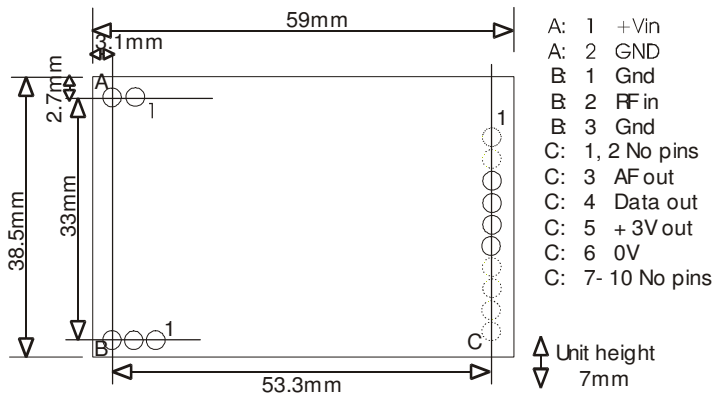

Figure 3: RX1L footprint (Top) view

Pin Description – RX1L

Pin A	Name	Function
1A	+Vin	3.1 - 9V
2A	0V	Ground
1B	Gnd	RF ground
2B	RF out	To the antenna
3B	Gnd	RF ground
1C	No pin	-
2C	No pin	-
3C	AF out	200mV _{pk-pk} audio. DC coupled, approx 1V bias
4C	DATA out	output of data slicer suitable for Biphase codes. 3V CMOS logic levels
5C	+3V out/in	DC supply. 10mA maximum drain. Present if unit is powered.
6C	0V	Ground
7C – 10C	No pins	-

NOTES:

1. '+3V out/in' can be used to power the RX1L receiver from an external regulated 3V supply.
2. While pin equivalent to the RX2M450, the RX1L lacks carrier detect, RSSI, modem or multi channel functions.

Condensed specifications

Frequency	151.300MHz or 171.225MHz (other frequencies on request)
<i>Frequency stability</i>	+/- 2.5kHz
<i>Channel spacing</i>	25kHz
<i>Number of channels</i>	1
Supply <i>voltage</i>	3.1 – 9V (or 3V +/- 10% via 3V out pin)
<i>Current</i>	1mA receive
Operating temperature	-10°C to +60°C (Storage -30°C to +70°C)
Size	59mm x 38mm x 7 mm
Spurious radiations	Compliant with ETSI EN 300 220-3 and EN 301 489-3
Interface	
<i>user</i>	4pin 0.1" pitch molex
<i>Power</i>	2pin 0.1" pitch molex
<i>RF</i>	3pin 0.1" pitch molex
Intended approval	ETSI Radio standard EN 300 220-3 and EMC standard EN 301 489-3
Sensitivity	-120dBm for 12 dB SINAD
<i>image / spurious</i>	-65dB
<i>blocking</i>	-80dB
<i>adjacent</i>	<-70dB (Tested per. ETSI EN 301 489-3)
channel	
Outputs	Audio, data
Power on to valid audio	20ms
Power on to stable data out (50:50 mark / space)	50ms

Notes:

1. The data slicer cannot be depended upon for data waveform frequencies below 250Hz
2. When RX is on and a transmitter keys up, again a 50ms period is required to stabilise data output mark/space. i.e. allow at least 50ms of preamble

Radiometrix Ltd

**Hartcran House
231 Kenton Lane
Harrow, Middlesex
HA3 8RP
ENGLAND**

**Tel: +44 (0) 20 8909 9595
Fax: +44 (0) 20 8909 2233
sales@radiometrix.com
www.radiometrix.com**

Copyright notice

This product data sheet is the original work and copyrighted property of Radiometrix Ltd. Reproduction in whole or in part must give clear acknowledgement to the copyright owner.

Limitation of liability

The information furnished by Radiometrix Ltd is believed to be accurate and reliable. Radiometrix Ltd reserves the right to make changes or improvements in the design, specification or manufacture of its subassembly products without notice. Radiometrix Ltd does not assume any liability arising from the application or use of any product or circuit described herein, nor for any infringements of patents or other rights of third parties which may result from the use of its products. This data sheet neither states nor implies warranty of any kind, including fitness for any particular application. These radio devices may be subject to radio interference and may not function as intended if interference is present. We do NOT recommend their use for life critical applications.

The Intrastat commodity code for all our modules is: 8542 6000

R&TTE Directive

After 7 April 2001 the manufacturer can only place finished product on the market under the provisions of the R&TTE Directive. Equipment within the scope of the R&TTE Directive may demonstrate compliance to the essential requirements specified in Article 3 of the Directive, as appropriate to the particular equipment.

Further details are available on The Office of Communications (Ofcom) web site:

<http://www.ofcom.org.uk/>

Information Requests

Ofcom

Riverside House

2a Southwark Bridge Road

London SE1 9HA

Tel: +44 (0)300 123 3333 or 020 7981 3040

Fax: +44 (0)20 7981 3333

information.requests@ofcom.org.uk

European Communications Office (ECO)

Pebblinghus

Nansensgade 19

DK 1366 Copenhagen

Tel. +45 33896300

Fax +45 33896330

ero@ero.dk

www.ero.dk
