

869/914 MHz Radio Packet Controller

Modules: RPC3G-914-64: IC + BiM3G-914-64
 RPC3G-869-64: IC + BiM3G-869-64

IC's: RPC-000-DIL: 18 pin DIL IC
 RPC-000-SO: 18 pin SO IC
 RPC-000-SS: 20 pin SSOP IC

The RPC3G is an intelligent transceiver modules, which enable a radio network/link to be simply implemented between a number of digital devices. The module combines a BiM3G UHF RF transceiver and a 64kbps packet controller.



RPC3G-914-64-RPSMA module

FEATURES

- Crystal controlled PLL FM circuitry for both Tx and Rx
- Up to 50 meter in-building range, 200m open ground
- Built-in self-test / diagnostics / status LED's
- Complies with ETSI EN 300 220-3
- Complies with ETSI EN 301 489-3
- Single 5V supply @ < 27mA
- 64kbps half duplex
- Free format packets of 1 - 27 bytes
- Packet framing and error checking are user transparent
- Collision avoidance (listen before transmit)
- Direct interface to 5V CMOS logic
- Power save mode

INTRODUCTION

The RPC3G is a self-contained plug-on radio port which requires only a simple antenna, 5V supply and a byte-wide I/O port on a host microcontroller (or bi-directional PC port).

The module provides all the RF circuits and processor intensive low level packet formatting and packet recovery functions required to inter-connect an number of microcontrollers in a radio network.

A data packet of 1 to 27 bytes downloaded by a Host microcontroller into the RPC3G's packet buffer is transmitted by the RPC3G's transceiver and will "appear" in the receive buffer of all the RPC3G's within radio range.

A data packet received by the RPC3G's transceiver is decoded, stored in a packet buffer and the Host microcontroller signalled that a valid packet is waiting to be uploaded.

RF specifications are provided on BiM3G-869-64, BiM3G-914-64 RF transceiver datasheet.

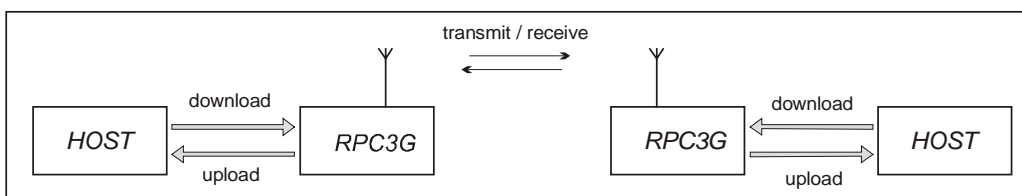

figure 1: RPC3G + Host μ -controller
 Radiometrix Ltd, RPC3G

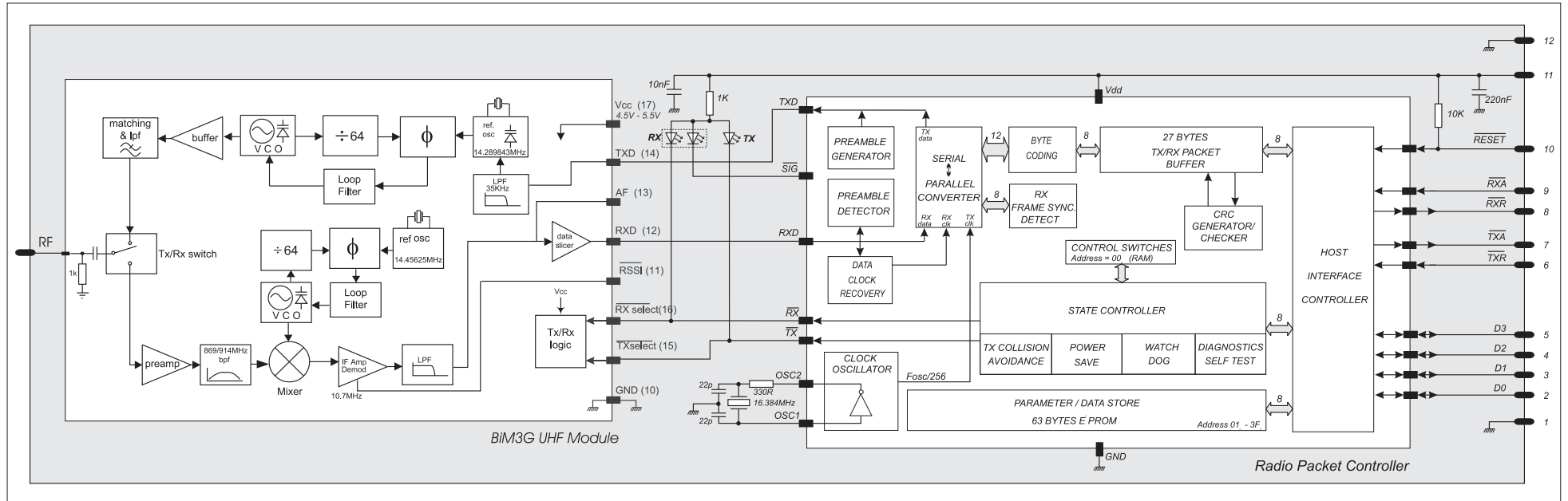

figure 2: RPC3G block diagram

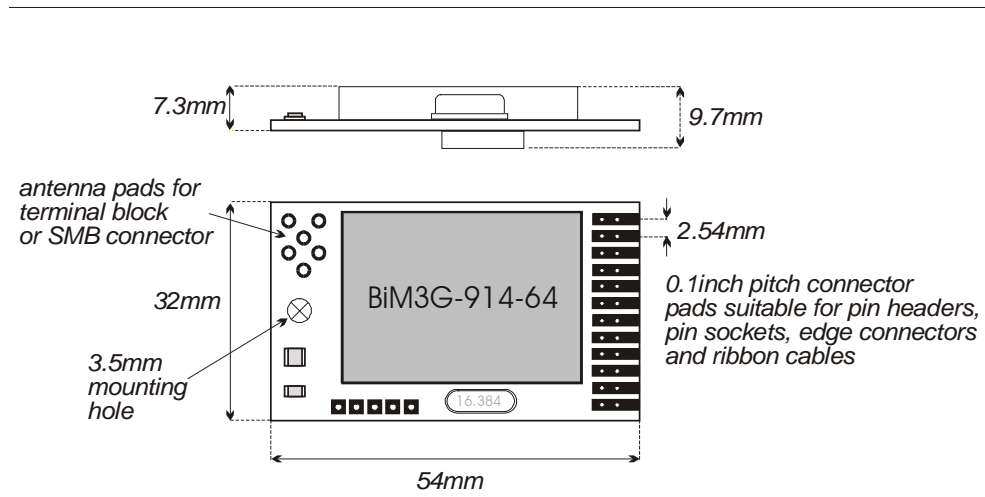

figure 3: physical dimensions

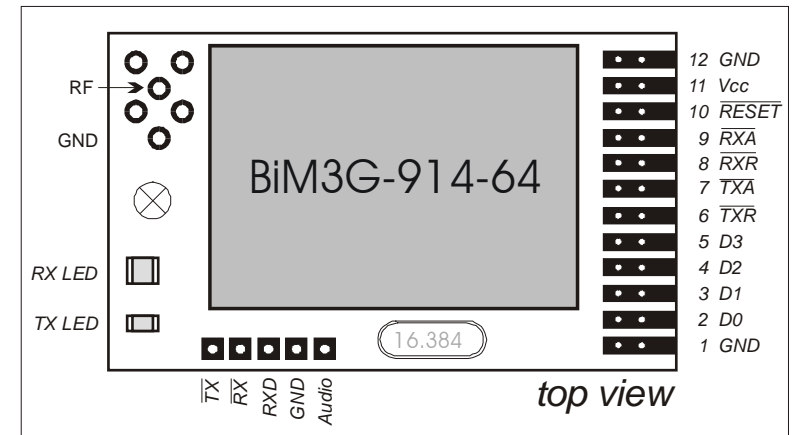

figure 4: RPC3G's pinout

1. FUNCTIONAL DESCRIPTION

On receipt of a packet downloaded by the Host, the RPC3G will append to the packet: Preamble, start byte and a error check code. The packet is then coded for security and mark:space balance and transmitted through the BiM3G RF Transceiver as a 64kbps synchronous stream. One of four methods of collision avoidance (listen before TX) may be user selected.

When not in transmit mode, the RPC3G continuously searches the radio noise for valid preamble. On detection of preamble, the RPC3G synchronises to the in-coming data stream, decodes the data and validates the check sum. The Host is then signalled that a valid packet is waiting to be unloaded. The format of the packet is entirely of the users determination except the 1st byte (the Control Byte) which must specify the packet type (control or data) and the packet size. A valid received packet is presented back to the host in exactly the same form as it was given.

To preserve versatility, the RPC3G does not generate routing information (i.e. source/ destination addresses) nor does it handshake packets. These network specific functions should be performed by the host.

Additional features of the RPC3G include extensive diagnostic/debug functions for evaluation and debugging of the radio and host driver software, a built in self test function and a sleep mode / wake-up mechanism which may be programmed to reduce the average current to less than 100 μ A. The operating parameters are fully programmable by the host and held in EEPROM, the host may also use the EEPROM as a general purpose non-volatile store for addresses , routing information etc.

1.1 OPERATING STATES

The RPC3G has four normal operating states:

- *IDLE / SLEEP*
- *HOST TRANSFER*
- *TRANSMIT*
- *RECEIVE*

IDLE/SLEEP

The *IDLE* state is the quiescent/rest state of the RPC3G. In *IDLE* the RPC3G enables the receiver and continuously searches the radio noise for message preamble. If the power saving modes have been enabled the RPC3G will pulse the receiver on, check for preamble and go back to *SLEEP* if nothing is found. The 'ON' time is 5ms, OFF time is programmable in the RPC3G's EEPROM and can vary between 22ms and 2.9s. The TX Request line from the Host is constantly monitored and will be acted upon if found active (low). A TX Request will immediately wake the RPC3G up from *SLEEP* mode.

HOST TRANSFERS

If the host sets the TX Request line low a data transfer from the Host to the RPC3G will be initiated. Similarly the RPC3G will pull RX Request low when it requires to transfer data to the Host (this may polled or used to generate a Host interrupt).

The transfer protocol is fully asynchronous, i.e. the host may service another interrupt and then continue with the RPC3G transfer. It is desirable that all transfers are completed quickly since the radio transceiver is disabled until the Host <-> RPC3G transfer is completed. Typically a fast host can transfer a 27 byte packet to / from the RPC3G in under 1ms.

TRANSMIT

On receipt of a data packet from the host, the RPC3G will append to the packet - preamble, frame sync byte and an error check sum. The packet is then coded for mark:space balance and transmitted. A full 27 byte packet is transmitted in 8.1ms of TX air time (64kb/s + 5ms preamble). Collision avoidance (Listen Before Transmit-LBT) functions can be enabled to prevent loss of packets.

Data packets may be sent with either normal or extended preamble. Extended preamble is used if the remote RPC3G is in power save mode. Extended preamble length can be changed in the EEPROM memory.

RECEIVE

On detection of preamble from the radio receiver, the RPC3G will phase lock, decode and error check the incoming synchronous data stream and if successful. The data is then placed in a buffer and the RX Request line is pulled low to signal to the host that a valid packet awaits to be uploaded to the Host.

An in-coming data packet is presented back to the host in the same form as it was given.

2. THE HOST INTERFACE

2.1 SIGNALS

It is recommended that the RPC3G be assigned to a byte wide bi-directional I/O port on the host processor. The port must be such that the 4 data lines can be direction controlled without affecting the 4 handshake line.

pin name	pin number	pin function	I/O	description
TXR	6	TX Request	I/P	Data transfer request from HOST to RPC3G
TXA	7	TX Accept	O/P	Data accept handshake back to HOST
RXR	8	RX Request	O/P	Data transfer request from RPC3G to HOST
RXA	9	RX Accept	I/P	Data accept handshake back to RPC3G
D0	2	Data 0 (4)	Bi-dir	4 bit bi-directional data bus. Tri-state
D1	3	Data 1 (5)	Bi-dir	between packet transfers, Driven on
D2	4	Data 2 (6)	Bi-dir	receipt for Accept signal until packet
D3	5	Data 3 (7)	Bi-dir	transfer is complete.

- Notes:**
1. The 4 Handshake lines are active low
 2. The 4 Data lines true data
 3. Logic levels are 5V CMOS, see electrical specifications
 4. Input pins have a weak pull-up internally

RESET

The Reset signal, may either be driven by the host (recommended) or pulled up to Vcc via a suitable resistor (10kΩ). A reset aborts any transfers in progress and restarts the Packet Controller.

HOST DRIVEN RESET

Minimum low time: 1.0 μs, after reset is released (returned high). The host should allow a delay 1ms after reset for the RPC3G to initialise itself

During this delay the host must hold TXR high (unless *DIAGNOSTIC MODES* are required) and RXR signal should be ignored.

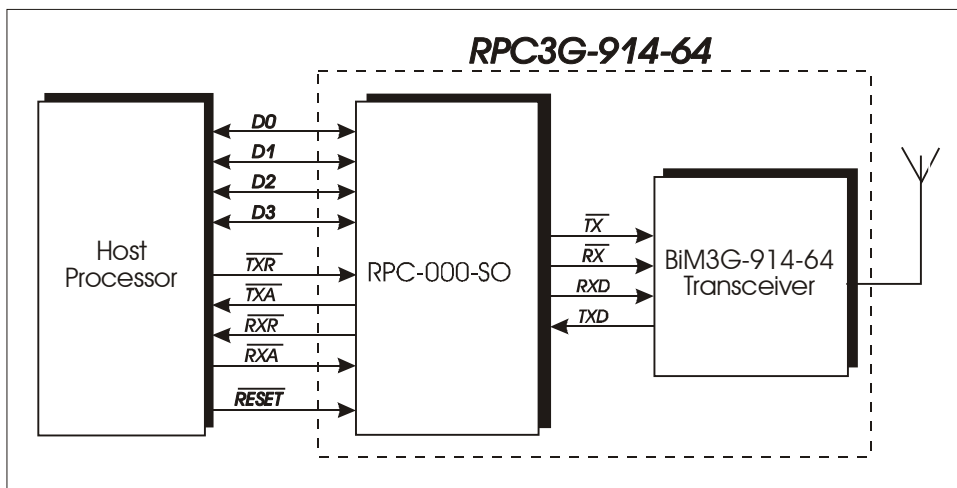

figure 5: Host to RPC3G connection

2.1.1 HOST TO RPC3G DATA TRANSFER

Data is transferred between the *RPC3G* and the *HOST* 4 bits (nibbles) at a time using a fully asynchronous protocol. The nibbles are always sent in pairs to form a byte, the *Least Significant Nibble* (bits 0 to 3) is transferred first, followed by the *Most Significant Nibble* (bits 4 to 7). Two pairs of handshake lines, *REQUEST* & *ACCEPT*, control the flow of data in each direction:-

TX Request & TX Accept: control the flow from the *HOST* to the *RPC3G* (download)
RX Request & RX Accept: control the flow from the *RPC3G* to the *HOST* (upload)

A packet transferred between host and *RPC3G* consists of between 1 and 28 bytes, the first byte of the packet is always the control byte.

There are two classes of *HOST* ↔ *RPC3G* transfers:

1. **Data Packets:** To the transmitter or from the receiver
2. **Memory Access:** To or from the *RPC3G*'s memory

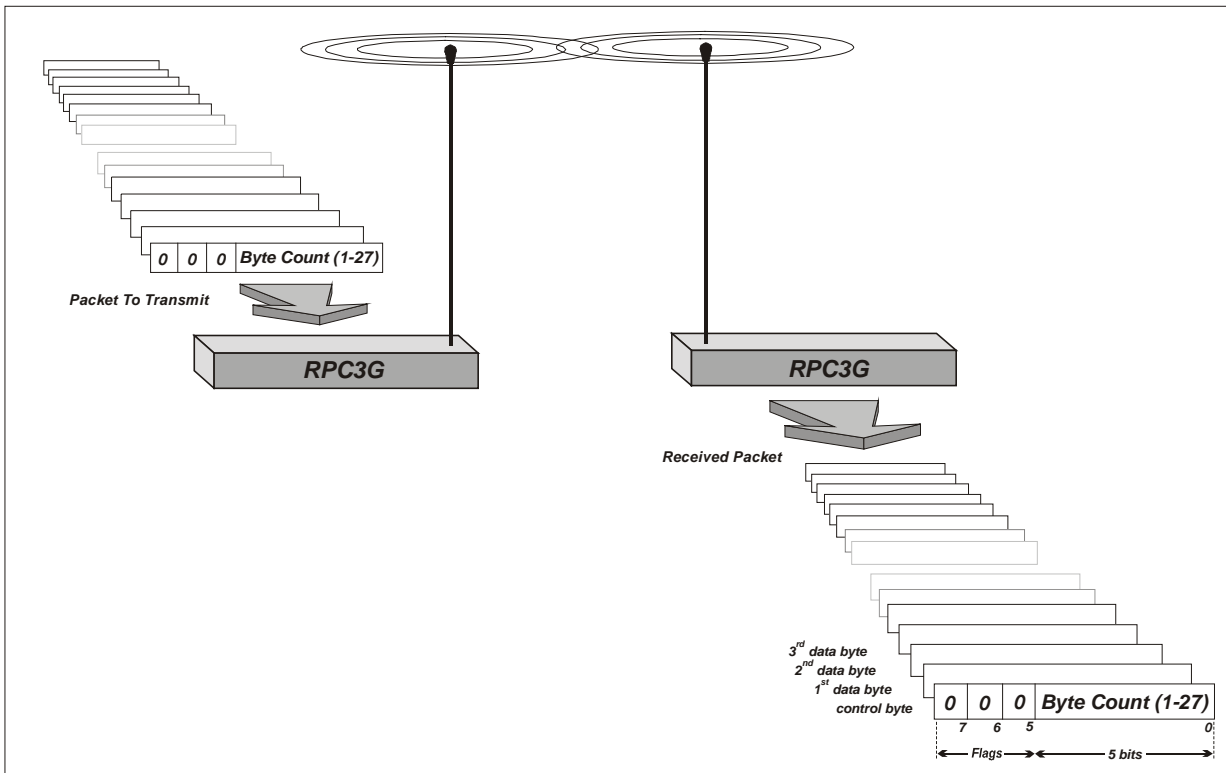

figure 6: *RPC3G* ↔ *Host* data transfer

2.1.3 READ A BYTE FROM THE RPC3G

The sequence for a byte transfer from the RPC3G to the HOST (i.e. RX upload) is asynchronous and proceeds as follows :-

1. RPC3G will assert RX Request line low to initiate transfer
2. Host pulls RX Accept low (i.e. request is accepted by the host)
3. RPC3G will turn on it's bus drivers, place LS nibble onto data lines and negate RX Request (set to 1)
4. Host reads the data and negates RX Accept (i.e. data has been accepted)

Repeat steps 1-4 with MS nibble.

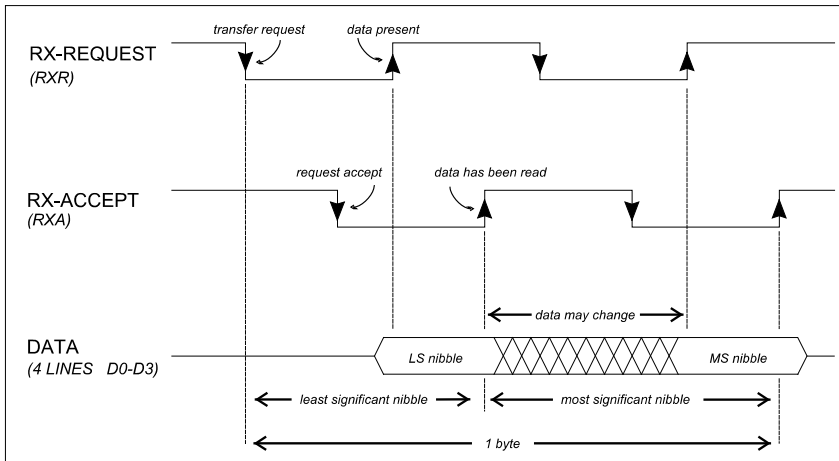

figure 8: RX upload timing diagram

Notes:

- The RPC3G will turn off it's data bus drivers after the entire packet has been uploaded to the HOST.
- See Appendix B and C. for example RPC3G driver subroutines.

2.2 HOST <> RPC3G PACKET FORMAT

2.2.1 THE CONTROL BYTE

The first byte of a RPC3G <> HOST packet transfer is always the *CONTROL BYTE*. This byte is used to control the transfer and contains information about the type of packet, number of bytes to be transferred, memory address, read/write bit etc. Bit 7 of the control byte is the Packet Type flag, PT, it determines the class of transfer and the interpretation of the other bits in the control byte.

2.2.2 SENDING AND RECEIVING DATA PACKETS

Data packets are sent to / received from remote RPC3G's. They begin with a control byte with bit 7 cleared and may be of variable length and contain up to 27 bytes of user determined data.

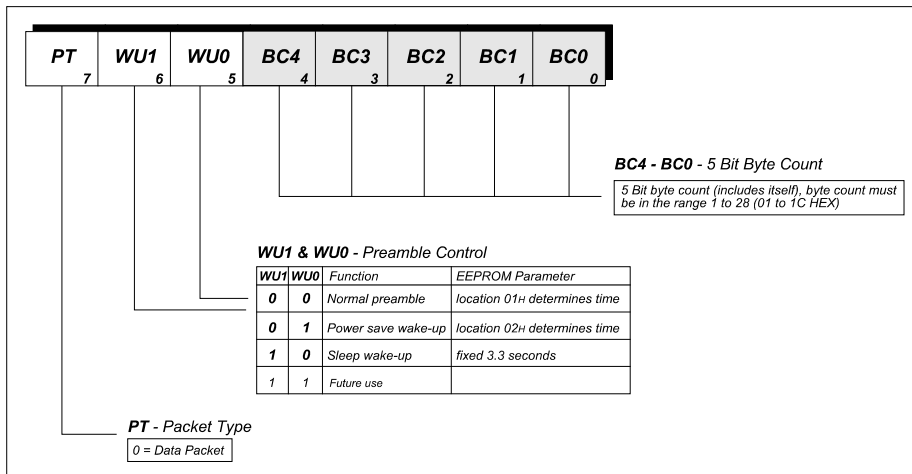

figure 9: Control byte for data packet

The remainder of the bytes in the data packet are of the users determination. The packet would usually be made up of a number of fields consisting of some but not necessarily all of the following :-

- Source address / ID
- Destination address / ID
- System ID
- Packet count
- Encryption / Scrambler control
- Additional error check codes (The RPC3G performs it's own error checks)
- Routing information (for repeaters)
- Link control codes (connect/disconnect/ACK/NAK etc.)
- Data field

2.2.3 RPC3G MEMORY ACCESS

The RPC3G's EEPROM memory can be accessed by setting bit 7 in the control byte. Bit 6 (R/W flag) defines a memory read or write. The bits left define the address.

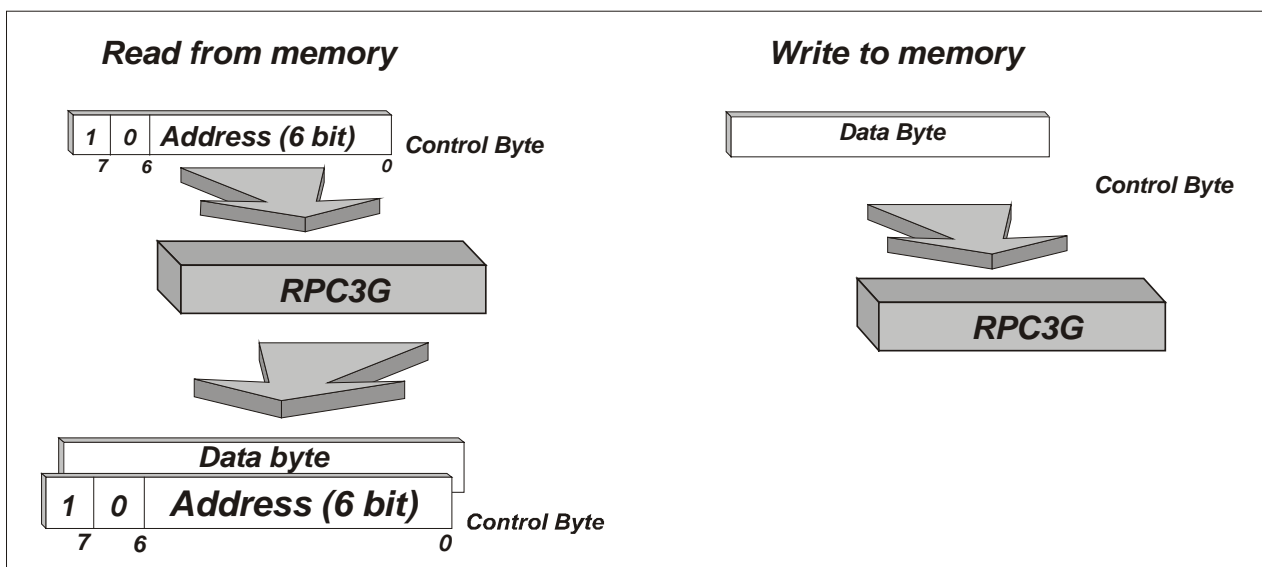

figure 10: RPC3G memory access

RPC3G Memory READS:

Host issues just the control byte, with bit 6 (W/R) cleared, bit 7 (PT) set and the memory address. The RPC3G will respond with 2 bytes, the first is a control byte which is an echo of the control byte just issued by the host, this is useful if the host is using an interrupt handler. The 2nd byte is the memory contents.

RPC3G Memory WRITES:

Host issues 2 bytes, the first is the control byte with bit 6 (W/R) set, bit 7 (PT) set and the memory address. The 2nd byte is the data to be written. The RPC3G does not give a response to memory writes.

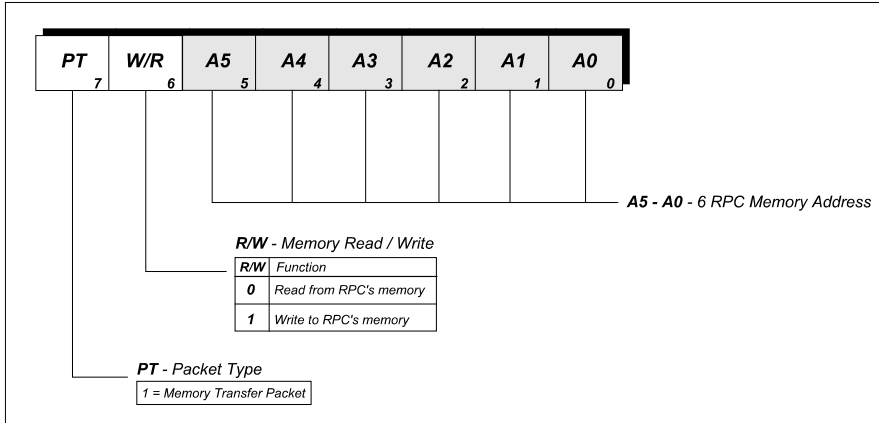

figure 11: Control byte for memory access

Notes Memory writes to locations 01 to 3F, write to the non-volatile EEPROM in the RPC3G. The EEPROM has a limit of 100,000 write cycles therefore its use must be restricted to infrequently changed data. The RPC3G only writes to the EEPROM when instructed to by the HOST. Each byte takes 10ms to write. To prevent accidental/spurious writes to EEPROM the host must set the WE bit in SWITCHES prior to EACH byte to be written. We recommend that the host performs a read/verify after each byte write to EEPROM.

The above does not apply to any memory reads nor to writes to SWITCHES (address 00h).

3.0 RPC3G's SWITCHES

SWITCHES is memory location 00h in RAM, it contains 8 flags which are used to determine the RPC3G's operation. On RPC3G reset, power-up or watchdog Time-Out it is loaded from location 08h (in EEPROM). The default value is 00 hex - this is all functions deselected.

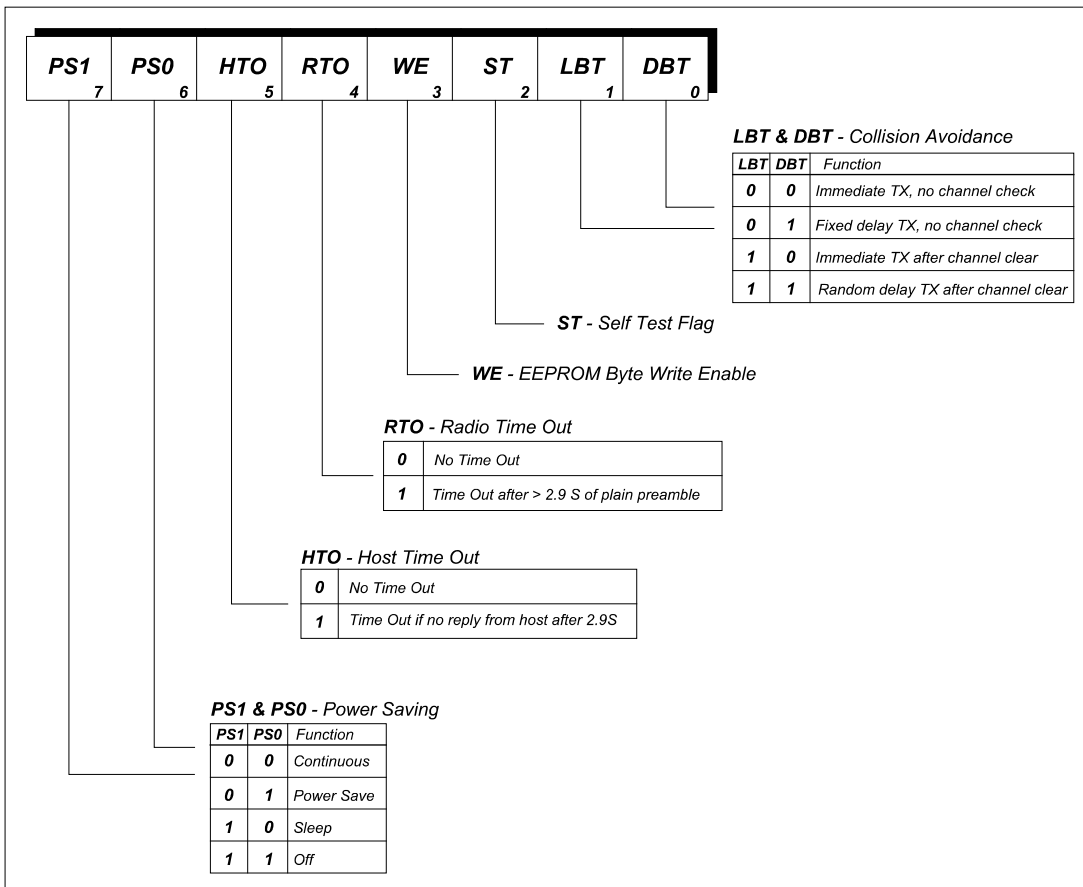

figure 12: Switches

3.1 PS0 & PS1 - POWER SAVING

The RPC3G has 4 levels of power saving selected by PS0 & PS1 in SWITCHES. Power saving is achieved by shutting down the Transceiver and the RPC3G for a period of time (*OFF-TIME*) when the RPC3G is in the Idle state (i.e. nothing happening). During the *OFF* period current is reduced to the device leakage of <50 μ A typ. The RPC3G will still respond immediately to a Host TX Request but cannot receive radio signals. After the programmed *OFF-TIME* the RPC3G will wake itself up, turn the receiver on and listen for valid preamble. ON time = PWR->RX (EEPROM address 05h) + 1ms = 4ms (using RPC3G Default values) If preamble is found the RPC3G will stay ON and decode the packet, if not the RPC3G will shut down for another OFF time period.

Also see - WAKE-UP (address 02h of EEPROM) and paragraph 2.2.2 .

PS1	PS0	Function	Current
0	0	CONTINUOUS	20mA (no power saving)
0	1	POWER SAVE	programmable sleeptime *
1	0	SLEEP	< 100 μ A (fixed off time of 2.9s)
1	1	OFF	< 50 μ A Transceiver is off (reset or TXR to wake-up)

* Sleeptime programmable in EEPROM address 03h.

value	off -time	Average current
00	22ms	2.95 mA
01	45ms	1.60 mA
02	90ms	0.85 mA
03	181ms	0.46 mA
04	362ms	0.26 mA
05	725ms	0.16 mA
06	1.45s	0.10 mA
07	2.9s	0.08 mA

The supply current's quoted above are typical for a BiM3G + RPC using the EEPROM default values.

3.2 HTO & RTO - INTERFACE TIME-OUT

Both the Host and the Radio interfaces can 'hang' the RPC3G while it waits for an external event. Under error conditions the RPC3G will reset itself if the appropriate HTO or RTO switch is set.

RTO RADIO TIME OUT.	
0	no time out
1	Time-Out and reset if > 2.9s of plain preamble detected. (note. valid extended preamble used for wake-ups will not cause a Time-Out to be detected)

HTO HOST TIME OUT	
0	no time out
1	Time-Out and reset if Host fails to reply to any request or handshake within 2.9s

3.3 WE - EEPROM WRITE ENABLE

This bit protects the EEPROM from accidental writes, it must be set to 1 prior to each byte write to the EEPROM (addresses 01h to 3Fh). This bit will be cleared by the RPC3G after each byte write.

3.4 ST - SELF TEST FLAG

Writing a 1 to this switch will initiate a radio self test. Both the transmitter and receiver are enabled, data is feed to the TX and checked for correct recover from the RX. If the test is good, the ST bit will set, if the test fails the ST bit will not set. The self test takes 20ms to complete.

3.5 LBT & DBT - COLLISION AVOIDANCE

Listen Before Transmit, LBT, and Delay Before Transmit, DBT determine what collision avoidance the RPC3G will take before each transmission.

LBT	DBT	Function
0	0	Immediate TX, no channel check
0	1	Fixed delay TX, no channel check (time slots) This is useful for rapid polling of up to 255 units by a master station. SLOTS is set to the units ID number, the packet size, preamble length and change over delay must be the same for all units being polled. see - EEPROM parameters
1	0	Immediate TX, if channel is clear The receiver is turned on and the channel checked for preamble or data. The RPC3G will only go to transmit when the channel is clear.
1	1	Random delay TX, if channel is clear This mode is useful in random access networks where there is a high statistical probability that more than 2 RPC3Gs could be attempting to transmit at the same time. The receiver is turned on and the channel is checked for preamble or data. If the channel is clear the RPC3G will go to transmit, if the channel is busy the RPC3G will delay by a random time (setable by TX-BACK-OFF in EEPROM) then try again for a clear channel.

4.0 USER CONFIGURABLE PARAMETERS IN EEPROM

The EEPROM has address range 01h - 3Fh (63 Bytes)

The first 15 BYTES (8 are defined) contain parameters used to control the RPC3G.

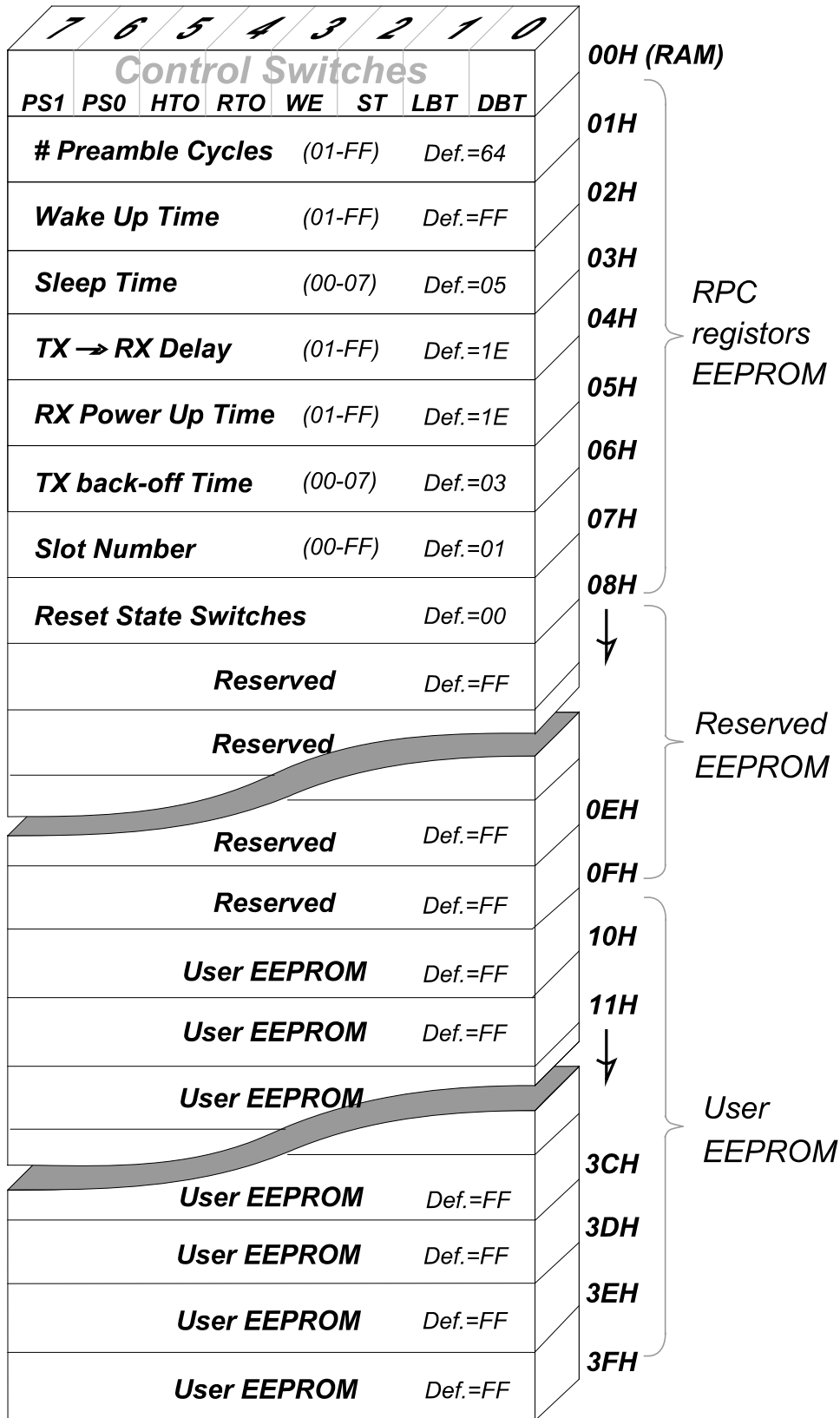

figure 13: RPC3G's EEPROM memory

PREAMBLE	Number of "01" preamble cycles on TX packets One '01' cycle takes 31.2µs @ 64kbit/s
address	01
default	A0
formula	Preamble time = PREAMBLE * 0.0312 ms
valid range	01 to FF

WAKE-UP	Number of units of 'WAKE-UP PREAMBLE + PLEASE HOLD LINE' To be sent as extended preamble to wake-up a remote RPC3G in power save mode. WAKE-UP should be set to approx. 1.5 times the remote units OFF Time
address	02
default	FF
formula	Wake-up message = WAKE-UP * 13.1 ms
valid range	01 to FF

SLEEP-TIME	Power Save 'Off' Time (RC controlled) The OFF time is controlled by an RC oscillator in the RPC3G which has a wide tolerance of +/- 30%
address	03
default	05
formula	Off-time = $22 * 2^{SLEEP-TIME}$ ms
valid range	00 to 07

TX ↔ RX	TX ↔ RX change over delay in units of 100µs
address	04
default	1E
formula	Delay = TX ↔ RX * 0.1 ms
valid range	01 to FF

PWR → RX	RX stabilisation delay in units of 100µs
address:	05
default:	1E
formula:	Delay = PWR → RX * 0.1 ms
valid range:	01 to FF

TX-BACK-OFF	Maximum TX Back-off delay in units of 1ms Used when LBT=1 & DBT=1	
address	06	
default	03	
formula	maximum delay = $(2^{TX-BACK-OFF} - 1)$ ms	
valid range	00 to 07	
	00 = 0 - 1 ms	04 = 0 - 31 ms
	01 = 0 - 3 ms	05 = 0 - 63 ms
	02 = 0 - 7 ms	06 = 0 - 127 ms
	03 = 0 - 15 ms	07 = 0 - 255 ms

TX-SLOT	0 - 255 slot number for delayed (polled) TX Delayed TX in packet units, used when LBT=0 & DBT=1
address	07
default	01
formula	delay = TX-Slot * (Preamble*0.05 + Tpacket + 3*TX ↔ RX + 0.5) ms where Tpacket = Number of bytes in packet * 0.30 ms
valid range	00 to FF

RESET STATE	RESET STATE OF SWITCHES The contents of this address are copied into SWITCHES on RPC3G reset, power-up or watchdog Time-Out
address	08
default	00

Address 09 to 0F are reserved for future and should not be used by the Host

EEPROM Addresses 10 TO 3F (48 BYTES) are free for Host use as general storage.

5.0 DIAGNOSTIC / DEBUG TEST MODES

These special test modes are useful for system testing and debugging

To select these modes the RPC3G should be released from reset with the TXR line held low, normal RPC3G operation will resume when the TXR is set high, i.e. TXR should be held while in these test modes.

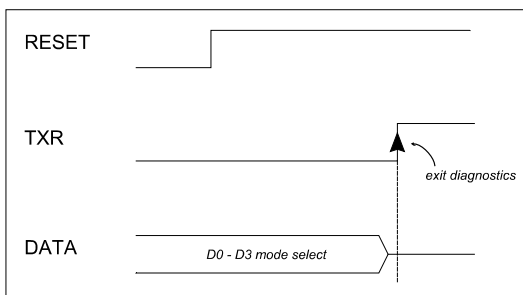

figure 14: diagnostic mode selection timing diagram

Note: For normal operation of the RPC3G the TXR line must be held high for either 1ms after a reset pulse or 100ms after a power up.

There are 9 test modes which are selected by a binary code applied to the RPC3G's data bus. A 4 bit DIL switch or rotary HEX switch connected between the data bus and 0V will select the modes (the RPC3G has weak internal pull-up's). Alternatively the HOST may select the test modes by holding TXR low, resetting the RPC3G and driving the required test mode code onto the data bus.

Note: The RPC3G continuously monitors the mode selected i.e.. a reset is not required on mode changes.

In some modes the RXR output from the RPC3G is driven low to indicate 'pass' or 'OK'. An LED + 1kΩ from RXR to 5V is recommended.

Mode	Name	Function
0	RX-ON	PREAMBLE DETECTOR ON (RXR RED LED = preamble detected)
1	RX-PULSE	10ms ON : 10ms OFF, PREAMBLE DETECTOR ON RXR LED
2	TX-ON-PRE	Preamble Modulation - send continuous preamble
3	TX-ON-SQ	100Hz SQUARE WAVE MOD - TX testing on spec. Analyser
4	TX-ON-255	random 64kbit/s data for EYE DIAGRAM tests, sync's on RXR
5	TX-PULSE	10ms ON : 10ms OFF, PREAMBLE BURSTS, RX lock in tests
6	ECHO	TRANSPONDER MODE, re-transmit any valid packets received
7	RADAR	Send ASCII TEST PACKET "RADIOMETRIX" and listen for echo
8	SELF-TEST	Loop test, TX > RX (OK on RXR)

Modes 6 & 7 are particularly useful for software debugging and range testing.

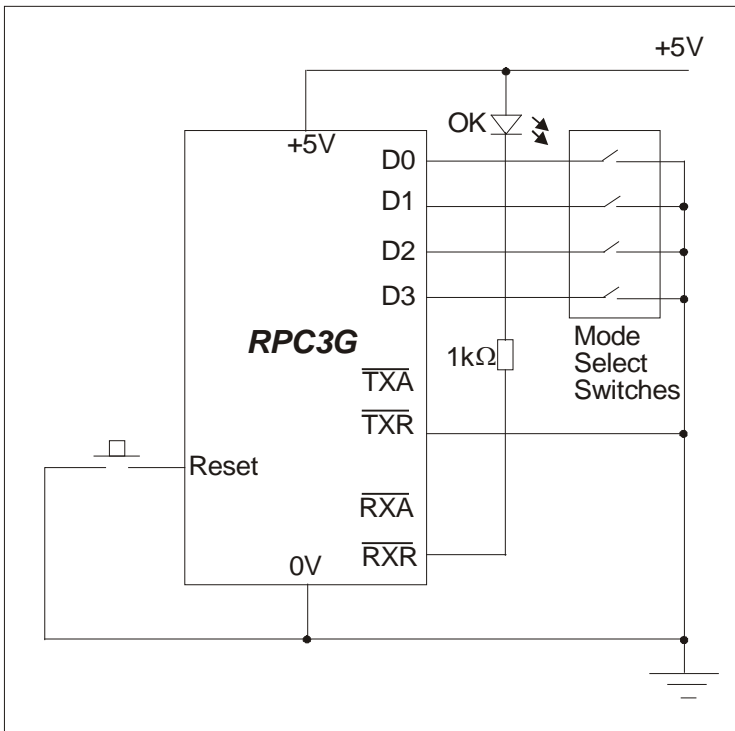

figure 15: stand-alone diagnostic mode

D3	D2	D1	D0	Mode
0	0	0	0	0
0	0	0	1	1
0	0	1	0	2
0	0	1	1	3
0	1	0	0	4
0	1	0	1	5
0	1	1	0	6
0	1	1	1	7
1	0	0	0	8

APPENDIX - A

A Detailed look at the RPC3G's transceiver interface

The RPC3G interfaces to the transceiver using 4 lines :-

TX	<i>output</i>	Active low enable for the transmitter.
TXD	<i>output</i>	Serial data to be sent.
RX	<i>output</i>	Active low enable for the receiver.
RXD	<i>input</i>	Received serial data.

- Note:**
- 1 All lines are 5V CMOS levels
 - 2 There is no requirement for a carrier/signal detect signal from the transceiver nor for the RXD output to be muted when no signal is present.

The enable lines - TX & RX

These normally high, active low lines are used to control the transceiver. The RPC3G is a half-duplex controller thus in normal operation the transceiver is either transmitting or receiving or off. The RPC3G only enables the TX and the RX at the same time during self test (local loop back).

Transmit Data - TXD

TXD is the serial data to the transmitter, it is held low when the transmitter is not enabled. When the TX is enabled a synchronous 64kbit/s (15.6µs/bit) serial code is present to modulate the transmitter.

Receive Data - RXD

RXD is a hi-impedance input which is fed with a 'squared-up' (5V logic level) signal from the receivers' data slicer. The RPC3G contains a very selective, noise immune signal detector and therefore does not require that the RXD signal be muted in the absence of signal, i.e.. squared-up channel noise may be fed to the RPC3G when no signal is present.

The RPC3G's Packet Encoder

The packet is made-up of 4 parts:

Preamble

This is a simple 32kHz square wave, the number of cycles being programmed by address 01h of the EEPROM. The preamble has two functions, the initial portion it is used to allow the data slicer in a remote receiver to establish the correct slicing point (for the A-433-64-S this takes a minimum of 3ms), after the receiver has settled, the remaining portion is used by the receiving RPC3G to positively identify and phase lock onto the incoming signal (this requires 15 cycles of preamble). The preamble may be extended to wake-up a remote RPC3G in power saving mode.

Frame sync

A 7 bit Barker sequence is used to identify the start of the data. Alternatively if the transmitter is sending extended preamble (to wake a power saving remote RPC3G) a complimented 7 bit Barker sequence is sent every 256 preamble cycles as a 'Please Hold The Line' code. An 8th balancing bit is added after the Barker sequence.

Data

Each byte in the RPC3G's buffer is expanded into a 12 bit symbol prior to sending. The symbol coding has the following properties :-

- Perfect 50:50 balance, i.e.. always 6 one's & 6 zero's
- There are never more than 4 consecutive one's or zero's. This minimises the low frequency components in the code and allows fast settling times to be used for the receivers' data slicer.
- Minimum Hamming distance = 2, i.e.. each code is different from any other code by a minimum of 2 bits, thus all odd number of bit errors will always be detected.
- In general only 256 of 4096 (6.25%) possible codes are valid, i.e.. a 93.75 % probability of trapping a byte error.
- Preamble and the Frame sync codes are not part of the symbol alphabet, a 'clash' signal will cause immediate termination of the current decode followed by an attempt to lock to the new signal.

Check Sum

Since the receiver checks each symbol for integrity, a simple 8 bit check sum is used to test for overall packet integrity. This is also coded into a 12 bit symbol prior to transmission.

[The RPC3G's Packet Decoder](#)

Signal Decoding is in 4 stages :-

Search

Initially the RPC3G's decoder searches the radio noise on the RXD line for the 32kHz preamble signal. The search is performed by a 16 times over-sampling detector which computes the spectral level of 32kHz in 240 samples of the RXD signal (750µs window). If the level exceeds a pre-set threshold the decoder will attempt to decode a packet.

Lock-in

The same set of 240 samples are used to compute the phase of the incoming preamble and synchronise the internal recovery clock to an accuracy of +/- 2µs. The recovery clock samples the mid point of each incoming data bit and shifts the samples through an 8 bit serial comparator. The comparator searches the data on a bit by bit basis for the frame sync byte. While the search is in progress, the decode will abort if the preamble fails to maintain a certain level of integrity. If the comparator finds the 'please hold the line' code used during extended wake-up preamble a phase re-lock is triggered to ensure accurate phase tracking until the actual packet arrives. When the frame sync is detected the decoder attains full synchronisation and will move to the Decode state.

Decode

Data is now taken in 12 bits at a time (one symbol), decoded into the original byte and placed in the receive buffer. The symbol decoder verifies each received symbol as valid (only 256 out of a possible 4096 are valid) and will immediately abort the decode on a symbol failure. The first byte contains the byte count and is used to determine the end of message.

Check Sum

The last byte is the received check sum, this is verified against a locally generated sum of all the received bytes in the packet. If it matches the packet is valid and RXR line will be pulled low to inform the Host that a packet awaits uploading.

[Notes on error handling](#)

The RPC3G's' decoder is deliberately non bit error tolerant, i.e.. no attempt is made to repair corrupt data bits. All of the redundancy in the code is directed towards error checking. For an FM radio link using short packet lengths, e.g. RPC3G + BiM3G , packets are either 100% or so grossly corrupt as to be unrecoverable. By the same reasoning, the Host is not informed when the RPC3G decoder aborts a packet decode since corrupt information is of little value. A packet acknowledge Time-Out and re-transmission is the preferred strategy for error handling.

Example RPC3G driver subroutines for Arizona PIC16C73

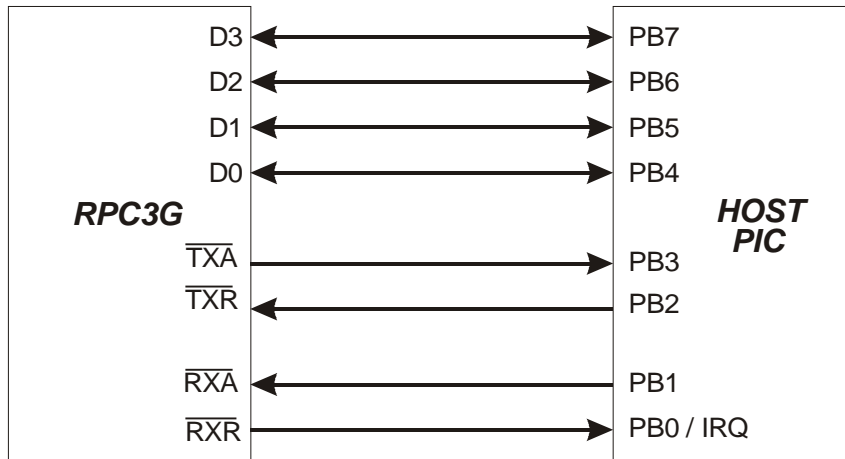

figure 16: RPC3G to PIC -µC interface

Packet transfers to / from the RPC3G are best handled in the host by two subroutines :- OUT_BYTE & IN_BYTE

Additionally LISTEN_BUS is called on completion of a packet transfer to the RPC3G to return the data bus to inputs (default state).

```

;-----;
;
;
;           RPC3G DRIVERS
;
;-----
;
;HOST PROCESSOR PIC16C73 or similar
;
RPC3G EQU  06      ;USE PORT B ON PIC
;
;           ** Bit assignments for RPC3G PORT **
;
D7  EQU  7      ;Bi-Dir
D6  EQU  6      ;Bi-Dir
D5  EQU  5      ;Bi-Dir
D4  EQU  4      ;Bi-Dir
TXA EQU  3      ;INPUT
TXR EQU  2      ;OUTPUT
RXA EQU  1      ;OUTPUT
RXR EQU  0      ;INPUT ON RB0, CAN BE CONFIGURED AS AN INTERRUPT
;
RPC3G_DDR EQU 86  ;Data direction register for port B (RPC3G)
;
;           ;This register is in BANK 1 of the register file
;
;-----
;
W  EQU  0      ;Accumulator as Destination
F  EQU  1      ;Register File as Destination
INDF EQU 00    ;INDirect File register
    
```

```

;SUBROUTINE IN_BYTE
;
;
;IN_BYTE    READ A BYTE FROM THE RPC3G INTO FILE POINTED TO BY FSR
;           W IS DESTROYED
;
;
;           NOTE THIS ROUTINE WILL HANG THE HOST UNTIL THE HOST
;           COMPLETES THE TRANSFER OF TWO NIBBLES
;
;           THIS SUBROUTINE CAN BE CONFIGURES TO RUN AS PART OF
;           AN INTERRUPT HANDLER IF THE :RXR LINE FROM THE RPC3G
;           IS USED TO TRIGGER A HOST INTERRUPT
;
;
;IN_BYTE    BTFSC RPC3G,RXR          ;WE GOT A RX REQUEST YET?
;           GOTO  IN-BYTE           ;NO , SO LOOP BACK AND WAIT
;
;
;           READ THE LS NIBBLE FROM THE RPC3G
;
;           BCF   RPC3G,RXA         ;ACCEPT THE REQUEST (SET ACCEPT LOW)
;
;AWAITDATA  BTFSS RPC3G,RXR         ;HAS REQUEST GONE UP? data is present
;           GOTO  AWAITDATA        ;LOOP BACK TILL IT DOES
;
;
;           NOP                    ;TIME DELAY TO ENSURE DATA STABLE
;           ;BEFORE READ
;
;
;           MOVF  RPC3G,W           ;READ THE LS NIBBLE FROM THE BUS
;           BSF   RPC3G,RXA         ;TELL RPC3G WE GOT NIBBLE (ACCEPT = 1)
;           ANDLW      B'11110000' ;JUST THE DATA
;
;
;           MOVWF      INDF         ;SAVE LS NIBBLE IN TARGET FILE (VIA FSR)
;           SWAPFINDF      ;RIGHT JUSTIFY LS NIBBLE
;
;           NOW GET MS NIBBLE FROM THE RPC3G
;
;INNIBBLE   BTFSC RPC3G,RXR         ;WE GOT NEXT RX REQUEST YET ?
;           GOTO  INNIBBLE         ;NO , SO LOOP BACK AND WAIT
;
;           BCF   RPC3G,RXA         ;ACCEPT REQUEST (SET ACCEPT LOW)
;
;AWAITD1    BTFSS RPC3G,RXR         ;HAS REQUEST GONE UP? data is present
;           GOTO  AWAITD1         ;LOOP BACK TILL IT DOES
;
;
;           NOP                    ;TIME DELAY TO ENSURE DATA STABLE
;           ;BEFORE READ
;
;
;           MOVF  RPC3G,W           ;READ THE MS NIBBLE FROM THE BUS
;           BSF   RPC3G,RXA         ;TELL RPC3G WE GOT NIBBLE (ACCEPT=1)
;           ANDLW      B'11110000' ;JUST THE DATA
;
;
;           IORWF INDF              ;COMBINE MS NIBBLE WITH LS NIBBLE
;           ;ALREADY IN THE FILE (VIA FSR)RETURN
;
;
; A BYTE HAS BEEN READ FROM THE RPC3G INTO ADDRESS POINTED AT BY FSR
;-----
;
;SUBROUTINE OUT_BYTE
;OUT_BYTE   WRITE A BYTE FROM FILE POINTED TO BY FSR TO RPC3G
;           W IS DESTROYED
;
;
;           NOTE THIS ROUTINE WILL HANG THE HOST UNTIL THE RPC3G
;           ACCEPTS THE TRANSFER OF TWO NIBBLES
;
;

```

```

;          WARNING   OUT_BYTE WILL SET THE DATA BUS TO DRIVE AFTER
;                   DETECTING A TXA FROM THE RPC3G.
;                   THE CALLING ROUTINE MUST SET 4 DATA LINES
;                   BACK TO I/P ON COMPLETION OF PACKET TRANSFER
;                   (i.e. call LISTENBUS)
;
;
OUT_BYTE   SWAPFINDF,W;GET LS NIBBLE FROM FILE (VIA FSR) INTO
;                   ;BITS 4 to 7 of W
;                   ANDLW      B'11110000' ;JUST THE NIBBLE
;                   IORLW B'00000010' ;SET TXR LOW, LEAVE RXA HIGH
;                   MOVWF      RPC3G      ;SET TXR LOW, OUTPUT NIBBLE
;
;
WACCEPT   BTFSC RPC3G,TXA ;WE GOT A TX ACCEPT BACK YET?
;         GOTO  WACCEPT   ;NO, SO LOOP BACK AND WAIT
;
;WE GOT ACCEPTANCE SO IT'S OK TO DRIVE BUS
;
;         BSF  STATUS,RP0 ;SELECT PAGE 1
;         MOVLW B'00001001' ;DRIVE BUS
;         MOVWF RPC3G_DDR
;         BCF  STATUS,RP0 ;SELECT PAGE 0 BUS IS NOW DRIVING
;
;         BSF  RPC3G,TXR ;REMOVE REQUEST, DATA IS ON BUS
;         BTFSS RPC3G,TXA ;HAS DATA BEEN READ?
;         GOTO WDUN      ;WAIT TILL RPC3G REMOVES ACCEPT
;
;LS NIBBLE OF (FSR) IS SENT , NOW DO MS NIBBLE
;
;         MOVF  INDF,W ;GET MS NIBBLE FROM FILE (VIA FSR)
;
;         ANDLW B'11110000' ;JUST THE MS NIBBLE
;         IORLW B'00000010' ;SET TXR LOW (BIT 2), RXA STAYS HIGH
;         MOVWF RPC3G      ;OUTPUT NIBBLE + TXR LOW
;
;
WACCEPT1  BTFSC RPC3G,TXA ;WE GOT A TX ACCEPT BACK YET?
;         GOTO  WACCEPT1  ;NO, SO LOOP BACK AND WAIT
;
;         BSF  RPC3G,TXR ;REMOVE REQUEST, DATA IS ON BUS
;
;
WDUN1     BTFSS RPC3G,TXA ;HAS DATA BEEN READ?
;         GOTO  WDUN1     ;WAIT TILL RPC3G REMOVES ACCEPT
;
;
;         RETURN
;
;
;         BYTE IS SENT TO RPC3G
;-----
; SUBROUTINE - LISTEN_BUS , SET DATA BUS TO INPUT
;
;
LISTEN_BUS BSF STATUS,RP0 ;SELECT PAGE 1
;         MOVLW B'11111001' ;BUS TO INPUT
;         MOVWF RPC3G_DDR
;         BCF  STATUS,RP0 ;SELECT PAGE 0
;         RETURN
;
;         BUS IS LISTENING TO RPC3G
;-----

```

Example RPC3G driver subroutines for Motorola 68HC11

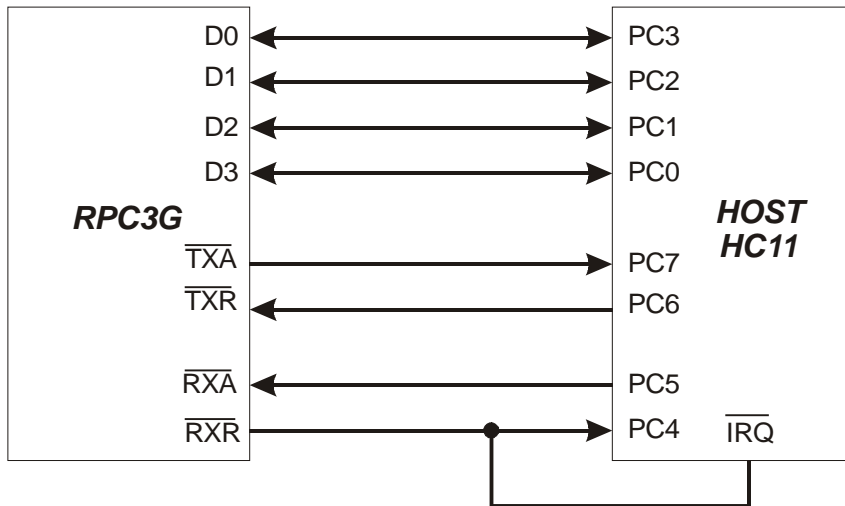

figure 17: RPC3G to HC11 μ -C interface

Packet transfers to / from the RPC3G are best handled in the host by two subroutines :- OUT_BYTE & IN_BYTE

Additionally LISTEN_BUS is called on completion of a packet transfer to the RPC3G to return the data bus to inputs (default state).

*

* CPU REGISTER EQUATIONS

*

*

*This section contains a few of the necessary register equations used
*in the example subroutines.

PORTC EQU \$1003 ;ADDRESS OF RPC3G PORT

DDRC EQU \$1007 ;DATA DIRECTION REGISTER PORT-C

- * Port-C7 = RX-accept OUTPUT
- * Port-C6 = RX-request INPUT
- * Port-C5 = TX-accept INPUT
- * Port-C4 = TX-request OUTPUT
- * Port-C3 = RPC3G data bit-3
- * Port-C2 = RPC3G data bit-2
- * Port-C1 = RPC3G data bit-1
- * Port-C0 = RPC3G data bit-0

* RANDOM ACCESS MEMORY *

ORG RAM ;RAM AREA DEFINITION

SAVE_1 RMB 1 ;TEMPORARILY SAVE LOCATION 1
SAVE_X RMB 2 ;HOLDS FILES POINTER FOR IN_BYTE

* SUBROUTINE: IN_BYTE *

*This subroutine is designed to be called by an interrupt handler to
*read a byte from the RPC3G into a file pointed at by X
*

*Note: The interrupt handler should load the X register with the file address before calling this subroutine.

IN_BYTE CLR SAVE_1 ;CLEAR TEMPORARILY MEMORY LOCATION
LDAB #10010000 ;SET CORRECT DATA DIRECTION i/p
STAB DDRC
WAIT_RQ LDAB PORTC ;WAIT FOR RX-REQUEST TO GO LOW
BITB #01000000 ;
BNE WAIT_RQ
IN_LP LDAB PORTC
ANDB #01111111 ;FORCE RX-ACCEPT TO GO LOW
STAB PORTC
WAIT_RQ1 LDAB PORTC ;WAIT FOR RX-REQUEST TO GO HIGH
BITB #01000000
BEQ WAIT_RQ1
DAT_INLDAA PORTC ;READ IN DATA
ANDA #00001111
LDAB PORTC ;FORCE ACCEPT HIGH
ORAB #10000000
STAB PORTC
STAA SAVE_1 ;SAVE NIBBLE TO TEMP LOCATION
WAIT_RQ2 LDAB PORTC ;WAIT FOR RX-REQUEST TO GO LOW
BITB #01000000
BNE WAIT_RQ2
IN_LP2 LDAB PORTC
ANDB #01111111 ;FORCE RX-ACCEPT TO GO LOW
STAB PORTC
WAIT_RQ3 LDAB PORTC ;WAIT FOR RX-REQUEST TO GO HIGH
BITB #01000000
BEQ WAIT_RQ3
DAT_IN2 LDAA PORTC ;READ IN DATA
ANDA #00001111
ASLA
ASLA
ASLA
LDAB PORTC ;FORCE ACCEPT HIGH
ORAB #10000000
STAB PORTC
ORAA SAVE_1 ;PUT NIBBLES TOGETHER IN TEMP LOCATION
STAA SAVE_1
READ_END STAA 0,X ;SAVE DATA TO POINTER ADDRESS

* SUBROUTINE: OUT_BYTE

*This subroutine will output of one byte to the RPC3G. Register X
*should contain the address of the memory location of the byte to be *send.
*Note: that register X has to be pre-loaded before entering this * subroutine.

```
OUT_BYTE   LDAA  0,X           ;GET THE BYTE TO SEND TO RPC3G
           ANDA  #%00001111   ;PREPARE LEAST SIGNIFICANT NIBBLE
           LDAB  PORTC
           ANDB  #%11101111   ;FORCE TX-REQUEST LOW
           STAB  PORTC
WAIT_ACC   LDAB  PORTC
           BITB  #%00100000   ;WAIT FOR TX ACCEPT TO GO LOW
           BNE  WAIT_ACC
           LDAB  #%10011111   ;CHANGE DATA DDRC TO OUTPUT
           STAB  DDRC        ;TURN BUS DRIVE ON
           ORAA  #%10000000   ;MAKE SURE RXA IS HIGH
           STAA  PORTC       ;OUTPUT DATA
           LDAB  PORTC
           ORAB  #%00010000   ;FORCE TX-REQUEST HIGH
           STAB  PORTC
WAIT_REQ   LDAB  PORTC       ;WAIT FOR TX_ACCEPT TO GO HIGH
           BITB  #%00100000
           BEQ  WAIT_REQ
           LDAA  0,X         ;PREPARE MOST SIGNIFICANT NIBBLE
           LSRA                ;BY SWAPPING THE LS- & MS-NIBBLE
           LSRA
           LSRA
           LSRA
           LDAB  PORTC
           ANDB  #%11101111   ;FORCE TX-REQUEST LOW
           STAB  PORTC
WAIT_TXA1  LDAB  PORTC       ;WAIT FOR TX-ACCEPT TO GO LOW
           BITB  #%00100000
           BNE  WAIT_TXA1
           ORAA  #%10000000
           STAA  PORTC       ;OUTPUT DATA
           LDAB  PORTC
           ORAB  #%00010000   ;FORCE TX-REQUEST HIGH
           STAB  PORTC
WAIT_TXR1  LDAB  PORTC       ;WAIT FOR TX_ACCEPT TO GO HIGH
           BITB  #%00100000
           BEQ  WAIT_TXR1
           RTS
```

* SUBROUTINE: LISTEN TO BUS

*

*This will turn the RPC3G host to listen mode again and should
*be called when the whole packet has been sent to the RPC3G

*

```
LISTEN_BUS LDAA  #%10010000   ;PUT PORT BACK TO LISTEN
           STAA  DDRC
           RTS
```

The RPC3G as a control IC

Clock frequency

All timings within the RPC3G (except sleep) are determined by the clock frequency. The standard frequency is 16.38MHz and all timings unless explicitly stated otherwise, assume this clock frequency.

$$\text{The data rate} = \frac{f_{\text{clk}}}{256} \text{ bit / s} \quad (\text{i.e. } 64\text{kb/s for } F_{\text{clk}}=16.38\text{MHz})$$

Clock accuracy

The RPC3G uses synchronous data transmission and requires an accurate reference clock. In the worst case, max. preamble and packet length, the allowable bit rate timing error between transmitter and receiver is 0.2 bits in 1000 bits, i.e. +/-200ppm total or +/-100ppm at each end.

$$\text{BIT TIME} = \frac{256}{f_{\text{xtal}}} \text{ Hz} \quad \text{i.e. } 16.38\text{MHz crystal} = 31.2\mu\text{s PER BIT}$$

Accuracy, temp drifts MUST KEEP X-TAL +/- 100ppm of nominal

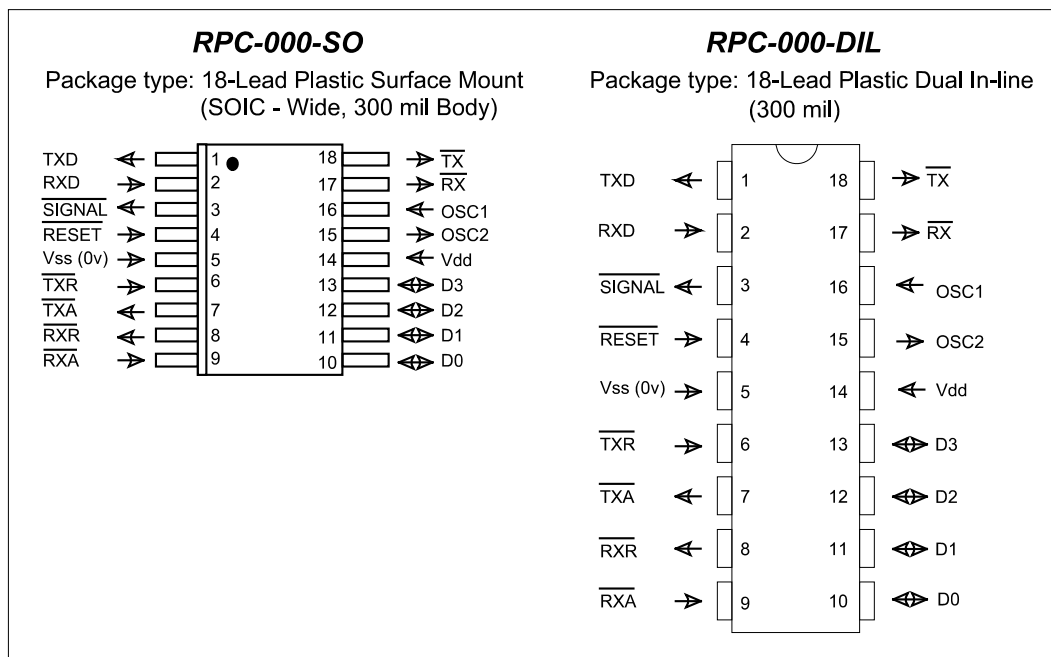

figure 18: RPC-000-SO & RPC-000-DIL outlines

APPENDIX - E

RPC3G-914-64-RPSMA Module is labelled as follows:

Radiometrix Ltd
Model: RPC3G-914-64-RPSMA
0.75mW 914.50MHz
FCC ID: TSK-RPC3G914RPS
IC: 9352A-RPC3G914RPS

Federal Communications Commission (FCC) Labelling Requirement

The Original Equipment Manufacturer (OEM) must ensure a clearly visible label on the outside of the final product enclosure that displays the text shown below to comply with FCC requirement.

Contains RPC3G-914-64-RPSMA
FCC ID: TSK-RPC3G914RPS
This device complies with Part 15 of the FCC Rules. Operation is subject to the following two conditions:
(1) this device may not cause harmful interference, and
(2) this device must accept any interference received, including interference that may cause undesired operation.

To reduce potential radio interference to other users, the antenna type and its gain should be so chosen that the equivalent isotropically radiated power (e.i.r.p.) is not more than that permitted for successful communication.

This device has been designed to operate with the supplied Reverse Polarity SMA (RPSMA) connector antenna (Radiometrix Part Number: ANT-914-W-RPSMA) to prevent usage of any prohibited antennas.

FCC, IC Label must be etched, engraved, stamped, indelibly printed, or permanently fixed on an exterior surface of the equipment and must be visible at the time of purchase (can be on the inside of the battery compartment of hand held equipment, but not on the battery cover. Battery cover must not require special tools for removal).

Industry Canada (IC) Labelling Requirement for the Host device

Contains IC: 9352A-RPC3G914RPS
This licence-exempt Low Power Device complies with RSS-210. Operation is subject to the following two conditions:
(1) this device may not cause interference, and
(2) this device must accept any interference, including interference that may cause undesired operation of the device.

Under Industry Canada regulations, this radio transmitter may only operate using an antenna of a type and maximum (or lesser) gain approved for the transmitter by Industry Canada. To reduce potential radio interference to other users, the antenna type and its gain should be so chosen that the equivalent isotropically radiated power (e.i.r.p.) is not more than that necessary for successful communication.

This radio transmitter (IC: 9352A-RPC3G914RPS) has been approved by Industry Canada to operate with the antenna types listed below with the maximum permissible gain and required antenna impedance for each antenna type indicated. Antenna types not included in this list, having a gain greater than the maximum gain indicated for that type, are strictly prohibited for use with this device.

Contient IC: 9352A-RPC3G914RPS
Le présent appareil est conforme aux CNR-210 d'Industrie Canada applicables aux appareils radio exempts de licence. L'exploitation est autorisée aux deux conditions suivantes :
(1) l'appareil ne doit pas produire de brouillage, et
(2) l'utilisateur de l'appareil doit accepter tout brouillage radioélectrique subi, même si le brouillage est susceptible d'en compromettre le fonctionnement.

Conformément à la réglementation d'Industrie Canada, le présent émetteur radio peut fonctionner avec une antenne d'un type et d'un gain maximal (ou inférieur) approuvé pour l'émetteur par Industrie Canada. Dans le but de réduire les risques de brouillage radioélectrique à l'intention des autres utilisateurs, il faut choisir le type d'antenne et son gain de sorte que la puissance isotrope rayonnée équivalente (p.i.r.e.) ne dépasse pas l'intensité nécessaire à l'établissement d'une communication satisfaisante.

Le présent émetteur radio (IC: 9352A-RPC3G914RPS) a été approuvé par Industrie Canada pour fonctionner avec les types d'antenne énumérés ci-dessous et ayant un gain admissible maximal et l'impédance requise pour chaque type d'antenne. Les types d'antenne non inclus dans cette liste, ou dont le gain est supérieur au gain maximal indiqué, sont strictement interdits pour l'exploitation de l'émetteur.

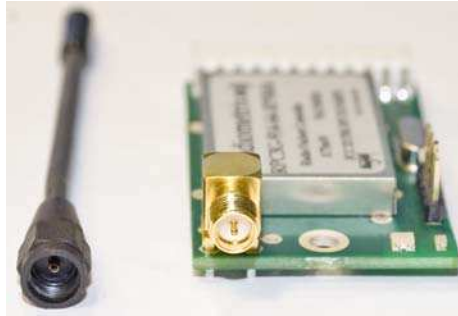

Fig 19: 914MHz 1/4 wavelength monopole antenna with Reverse Polarity SMA connector (ANT-914-W-RPSMA)

Radiometrix Ltd

**Hartcran House
231 Kenton Lane
Harrow, Middlesex
HA3 8RP
ENGLAND
Tel: +44 (0) 20 8909 9595
Fax: +44 (0) 20 8909 2233
sales@radiometrix.com
www.radiometrix.com**

Copyright notice

This product data sheet is the original work and copyrighted property of Radiometrix Ltd. Reproduction in whole or in part must give clear acknowledgement to the copyright owner.

Limitation of liability

The information furnished by Radiometrix Ltd is believed to be accurate and reliable. Radiometrix Ltd reserves the right to make changes or improvements in the design, specification or manufacture of its subassembly products without notice. Radiometrix Ltd does not assume any liability arising from the application or use of any product or circuit described herein, nor for any infringements of patents or other rights of third parties which may result from the use of its products. This data sheet neither states nor implies warranty of any kind, including fitness for any particular application. These radio devices may be subject to radio interference and may not function as intended if interference is present. We do NOT recommend their use for life critical applications.

The Intrastat commodity code for all our modules is: 8542 6000.

R&TTE Directive

After 7 April 2001 the manufacturer can only place finished product on the market under the provisions of the R&TTE Directive. Equipment within the scope of the R&TTE Directive may demonstrate compliance to the essential requirements specified in Article 3 of the Directive, as appropriate to the particular equipment.

Further details are available on The Office of Communications (Ofcom) web site:

<http://www.ofcom.org.uk/radiocomms/ifi/>

Information Requests
Ofcom
Riverside House
2a Southwark Bridge Road
London SE1 9HA
Tel: +44 (0)845 456 3000 or 020 7981 3040
Fax: +44 (0)20 7783 4033
information.requests@ofcom.org.uk

European Radiocommunications Office (ERO)
Pebblinghus
Nansensgade 19
DK 1366 Copenhagen
Tel. +45 33896300
Fax +45 33896330
ero@ero.dk
www.ero.dk