

Bluetooth-Module PAN1321



(Module with shielding)

OUTLINES - ENW89811J4CF



Now you can integrate Bluetooth very easy in your final product, with the PAN1321-SPP as a full Bluetooth system solution.

In comparison to our pin compatible HCI solution (PAN1310), there is no longer a powerful host needed.

The PAN1321 is manufactured in a 15,6 x 8,7 x 2.8 mm³ SMD LGA package with shielded case and will be qualified to the Bluetooth 2.0 standard.

Due to a very low price PAN1321 is well suited for units produced in all quantities, with the simple AT command set you are able to integrate PAN1321 into your application. This module follows the national and international regulations, e.g. EMC, Safety, EN300328, FCC.

FEATURES

General

- Supported Profiles: RFCOMM, SPP device A and B
- Complete Bluetooth 2.0 + EDR solution
- Ultra low power design
- Temperature from -40°C to +70°C, optional +85°C (Industrial Range)
- No external components needed
- Integrates ARM7TDMI, RAM and patchable 256k EEPROM (for device configuration data and application)
- On-module voltage regulator. External supply 2.7-3.6V
- Reference clock included
- Low power clock from internal oscillator or external low power clock

Interfaces

- 3.25 Mbaud UART
- General purpose I/Os with interrupt and wake-up capabilities
- JTAG for boundary scan and debug

Bluetooth

- Scatternet with one slave role while still being visible
- Power control and RSSI
- Sniff mode, Adaptive Frequency Hopping and Quality of Service

ORDERING CODE

- PAN1321 with SPP and max. +70°C ENW89811J4CF
- PAN1321 with SPP and max. +85°C (on request for higher demand)

MODULES
Panasonic Electronic Devices Europe GmbH
WIRELESS

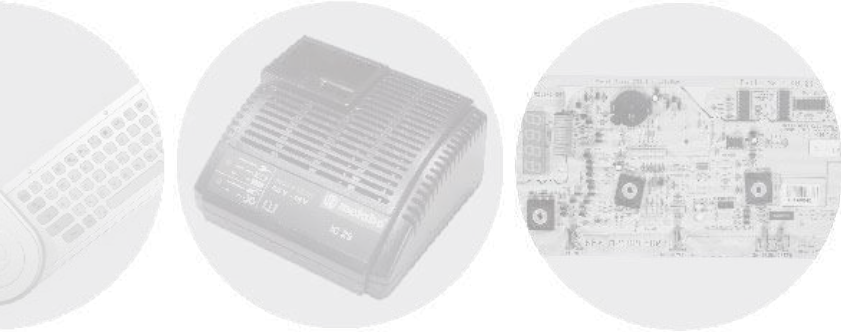

CONTACT

Carsten Pfaff
Bluetooth Product Manager

Radiometrix Ltd
Hartcran House
231 Kenton lane, Harrow, Middlesex
HA3 8RP, England.

Tel: +44 (0)20 8907 5077
Fax: +44 (0)20 8909 2233
email: carsten@radiometrix.co.uk

APPLICATIONS

All Wireless Applications

- Printer Adapters and Scanners
- Printers
- Access Points
- Wireless Sensors
- Cable Replacement
- Personal Digital Assistants (PDAs)
- PC Motherboards & - Peripherals
- Industrial Applications

BLOCK DIAGRAM

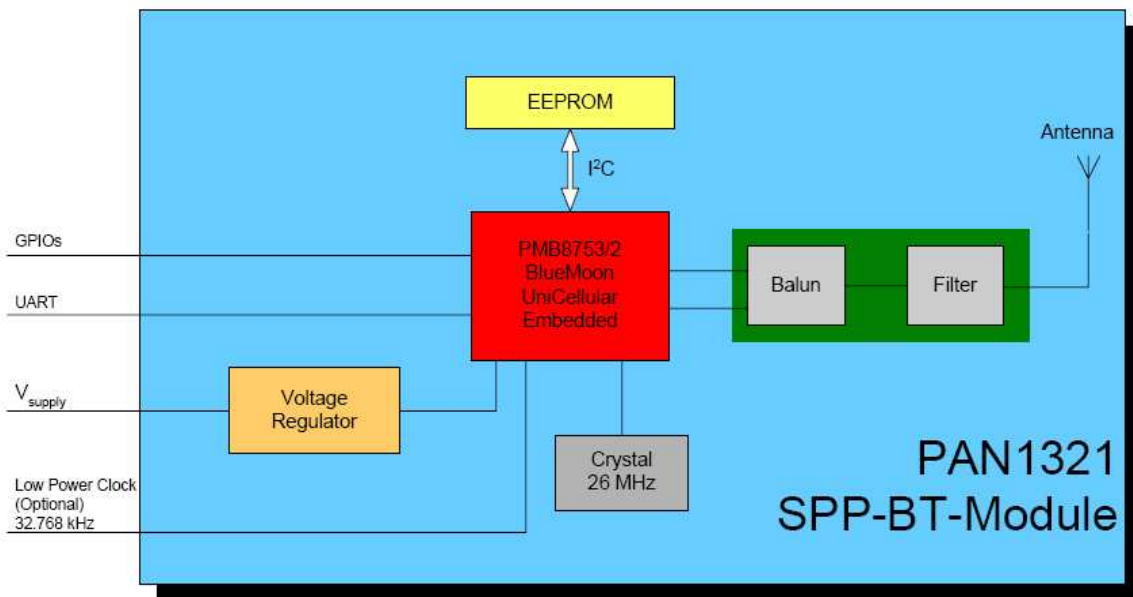

TECHNICAL CHARACTERISTICS

Parameter	Value	Condition / Note
Receiver Sensitivity (BER=10 ⁻³)	-86 dBm typ.	ideal wanted signal
Output Power	+3 dBm typ.	@ 50 Ohm antenna pin
Power Supply	2,7 - 3,6 V	Single operation voltage
Ultra Low Power Mode	80µA	T = 25°C
ACL (Transmit 3-DH1)	40mA	Enhanced Data Rate, 531.2 kb/s ⁽¹⁾
ACL (Receive 3-DH1)	37mA	Enhanced Data Rate, 531.2 kb/s ⁽¹⁾
Operating Temperature Range	-40°C to +70°C	optional +85°C

(1) Figure indicates maximum possible data rate with this packet type.
Total throughput depends on application and interface setting.