

UHF Narrow Band FM Transceiver

The narrow band NiM2 transceiver offers a low power, reliable data link in a Radiometrix transceiver standard pin out and footprint. This makes the NiM2 ideally suited to those low power applications where existing single frequency wideband UHF modules have insufficient range.



Figure 1: NiM2-434.650-10

Features

- Conforms to ETSI EN 300 220-3 (radio) and EN 301 489-3 (EMC)
- Standard frequency: 434.65 and 434.075MHz
- Custom frequencies available in 433MHz (EU) band
- Data rates up to 10kbps
- Usable range over 500m
- 25kHz Channel spacing
- Longer range compared to Wide Band FM modules

Available for licence-exempt operation in the 433MHz EU band, the NiM2 modules combine effective screening with internal filtering to minimise spurious radiation and susceptibility thereby ensuring EMC compliance. They can be used in existing low data rate (<10kbps) applications where the operating range of the system using wide band transceivers need to be extended. Because of their small size and low power consumption, NiM2 is ideal for use in battery-powered portable applications.

NiM2 is also available as separate NiM2T transmitter and NiM2R receiver, which can be used as dual-in-line equivalents of NTX2 transmitter and NRX2 receiver respectively.

Applications

- EPOS equipment, barcode scanners
- Data loggers
- Industrial telemetry and telecommand
- In-building environmental monitoring and control
- High-end security and fire alarms
- DGPS systems
- Vehicle data up/download

Technical Summary

- 3 stage crystal controlled VCXO
- Data bit rate: 10kbps max.
- Transmit power: +10dBm (10mW)
- Double conversion FM superhet
- SAW band pass filter, image rejection: 50dB
- Data bit rate: 10kbps max.
- Receiver sensitivity: -118dBm (for 12dB SINAD)
- RSSI output with >60dBm range
- Adjacent Channel: -70dBm
- Supply: 2.9V - 15V @ 20 mA transmit, 15mA receive (internal 2.8V voltage regulator)

Evaluation platforms: NBEK + BiM / SMX carrier

NiM2 Single channel transceiver

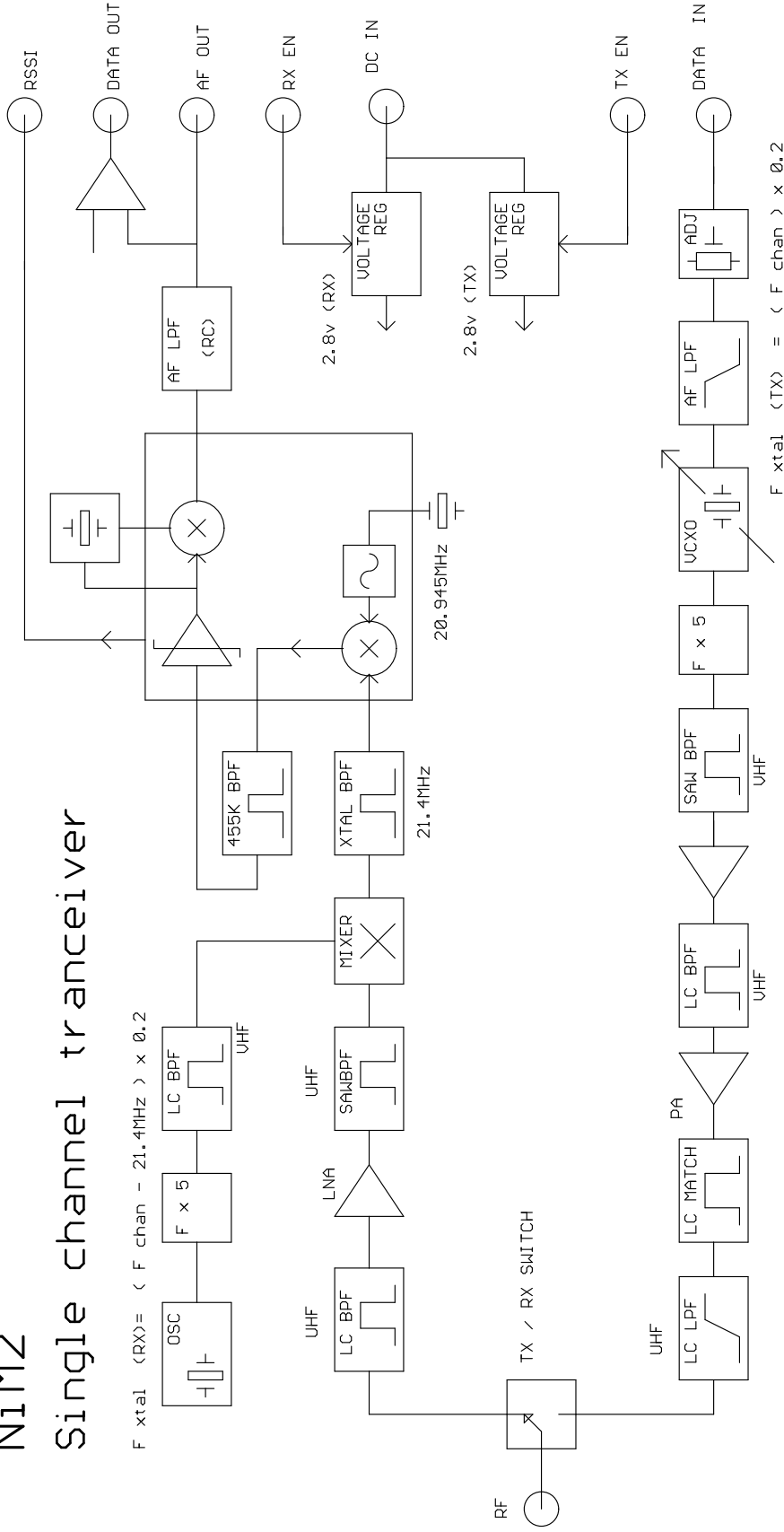

Figure 2: NiM2-434.650-10

Functional description

The transmit section of the NiM2 consists of a frequency modulated Voltage Controlled Crystal Oscillator (VCXO) feeding a frequency doubler with two stage amplifier and RF filter. Final Power Amplifier stage is factory pre-set to appropriate band power level. Operation is controlled by a Tx Select line, the transmitter achieving full RF output typically within 5ms of this line being pulled low. The RF output is filtered to ensure compliance with the appropriate radio regulations and fed via a fast Tx/Rx changeover switch to the 50Ω antenna pin.

The receive section is a double conversion FM superhet with IF at 21.4MHz and 455kHz fed by a Low Noise Amplifier (LNA) on the RF front-end. The receiver is controlled by RX Select line and will power up typically <2ms. Quadrature detector output is available as Audio Frequency (AF) output and transmitted digital data is regenerated from AF using adaptive data slicer. A Received Signal Strength Indicator (RSSI) output with some 60dB of range is provided.

User interface

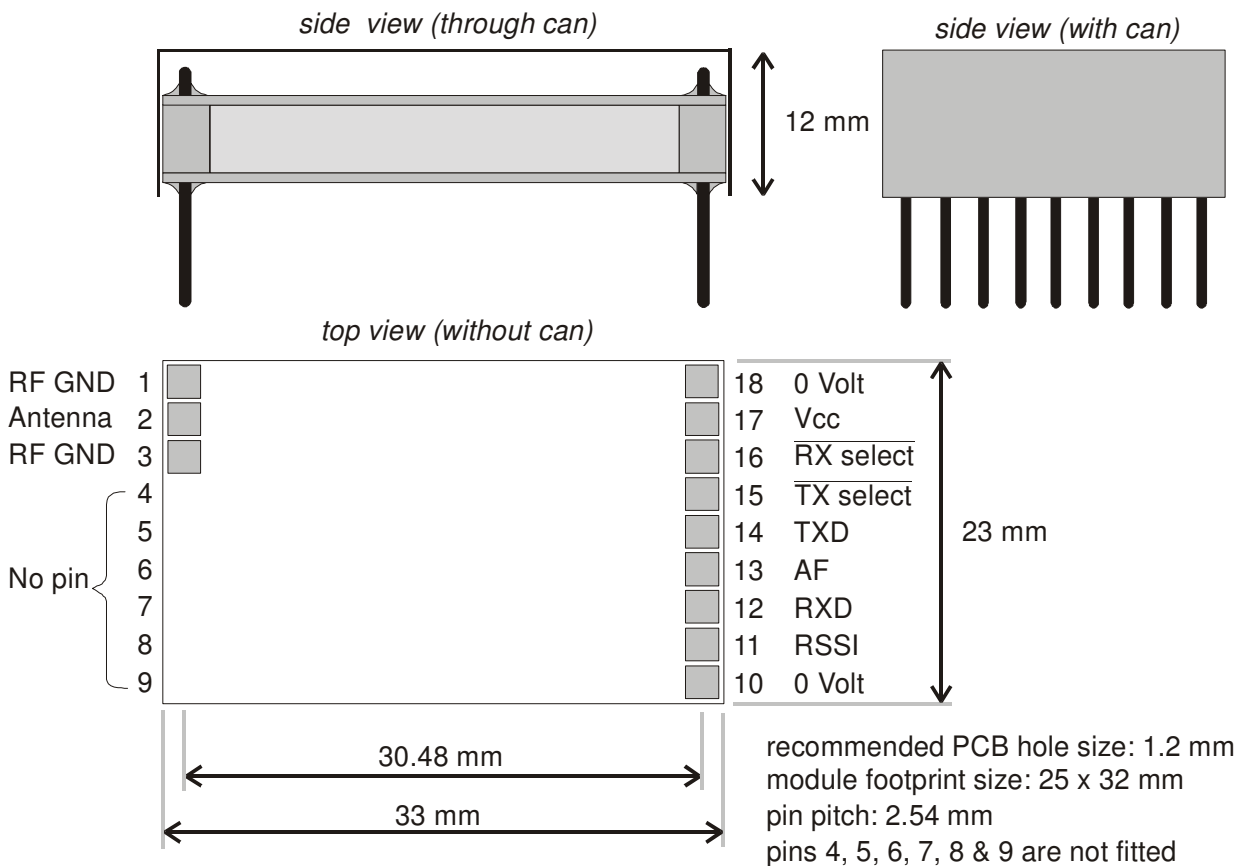

Figure 3: NiM2 pin-out and dimension

NiM2 Pin	Name	Function
1, 3, 10, 18	0V	Ground
17	VCC	2.9 – 15V DC power supply
16	$\overline{\text{RX}}$	Pull low to enable Receiver
15	$\overline{\text{TX}}$	Pull low to enable Transmitter
14	TXD	DC coupled input for 3V CMOS logic. $R_{in} = 100k\Omega$
13	AF	500mV _{pk-pk} audio. DC coupled, approx 0.8V bias
12	RXD	RXD is an open collector output, with a 10kΩ pullup to Vcc. Suitable for Biphase codes
11	RSSI	DC level between 0.5V and 2V. 60dB dynamic range

NOTES:

- $\overline{\text{RX}}$ and $\overline{\text{TX}}$ have internal (10kΩ approx.) pull-ups to Vcc
- Avoid $\overline{\text{RX}}$ and $\overline{\text{TX}}$ both low: undefined module operation (but damage will not result)
- Pin out is as BiM1, BiM2. On RF connector end only pins 1, 2 and 3 are present.

Absolute maximum ratings

Exceeding the values given below may cause permanent damage to the module.

Operating temperature	-10°C to +60°C
Storage temperature	-30°C to +70°C
RF in (pin 1)	±50V @ <10MHz, +13dBm @ >10MHz
All other pins	-0.3V to +15.0V

Performance specifications:

(Vcc = 3V / temperature = 20°C unless stated)

General	pin	min.	typ.	max.	units	notes
DC supply						
Supply voltage	17	2.9	-	15	V	
TX Supply current (10mW)	17		20		mA	
RX Supply current	17		15		mA	
Antenna pin impedance	2		50		Ω	
RF centre frequency			434.650		MHz	
			434.075		MHz	
Channel spacing			25		kHz	
Number of channels			1			
Transmitter						
RF						
RF power output	2	+9	+10	+11	dBm	1
Spurious emissions	2			-36	dBm	2
Adjacent channel TX power			-37		dBm	
Frequency accuracy		-2.5	0	+2.5	kHz	3
FM deviation (peak)		±2.5	±3.0	±3.5	kHz	4
Baseband						
Modulation bandwidth @ -3dB		0		5	kHz	
TXD input level (logic low)	14		0		V	5
TXD input level (logic high)	14		3.0		V	5
Dynamic timing						
TX select to full RF				5	ms	
Receiver						
RF/IF						
RF sensitivity @ 12dB SINAD	2, 13		-118		dBm	
RF sensitivity @ 1ppm BER	2, 12		-112		dBm	
RSSI range	2, 11		60		dB	6
IF bandwidth			TBA		kHz	
Blocking	2		80		dB	
Image rejection	2		55		dB	
Adjacent channel rejection	2		70		dB	2
Spurious response rejection	2		65		dB	
LO leakage, radiated			-60		dBm	3
Baseband						
Baseband bandwidth @ -3dB	13		5		kHz	
AF level	13		500		mV _{P-P}	7
DC offset on AF out	13		0.8		V	
Distortion on recovered AF	12		TBA		%	
Load capacitance, AF / RXD	12,13		TBA		pF	
Dynamic timing						
Power up with signal present						
Power up to stable AF output	16, 13		2			
Power up to stable RXD output	16, 12		10		ms	

<i>Signal applied with supply on</i>						
Signal to valid AF	2, 11		TBD		ms	
Signal to stable data	2, 12		TBD		ms	
Time between data transitions	12			0.1	ms	8
Mark : space ratio	12	20	50	80	%	8

Notes:

1. Measured into 50Ω resistive load.
2. Exceeds EN/EMC requirements at all frequencies.
3. Total over full supply and temperature range.
4. With 0V – 3.0V modulation input.
5. To achieve specified FM deviation.
6. See applications information for further details.
7. For received signal with ±3kHz FM deviation.
8. For 50:50 mark to space ratio (i.e. squarewave).

Applications information

Power supply requirements

The NiM2 have built-in regulators which deliver a constant 2.8V to the transmitter and the receiver circuitry when the external supply voltage is 2.9V or greater. This ensures constant performance up to the maximum permitted rail, and removes the need for external supply decoupling except in cases where the supply rail is extremely poor (ripple/noise content $>0.1V_{p-p}$).

TX modulation requirements

The module is factory-set to produce the specified FM deviation with a TXD input to pin 14 of 3V amplitude, i.e. 0V "low", 3V "high"

If the data input level is greater than 3V, a resistor must be added in series with the TXD input to limit the modulating input voltage to a maximum of around 2V on pin 7. TXD input resistance is 100k Ω to ground, giving typical required resistor values as follows:

Vcc	Series resistor
$\leq 3V$	-
3.3V	10 k Ω
5V	68k Ω
9V	220k Ω

RX Received Signal Strength Indicator (RSSI)

The NiM2 wide range RSSI which measures the strength of an incoming signal over a range of 60dB or more. This allows assessment of link quality and available margin and is useful when performing range tests.

The output on pin 11 of the module has a standing DC bias of up to 0.5V (approx.) with no signal, rising to around 2.0V at maximum indication. DVmin-max is typically 1V and is largely independent of standing bias variations. Output impedance is 56k Ω . Pin 11 can drive a 100 μ A meter directly, for simple monitoring.

Please note that the actual RSSI voltage at any given RF input level varies somewhat between units. The RSSI facility is intended as a relative indicator only - it is not designed to be, or suitable as, an accurate and repeatable measure of absolute signal level or transmitter-receiver distance.

Typical RSSI characteristic is as shown below:

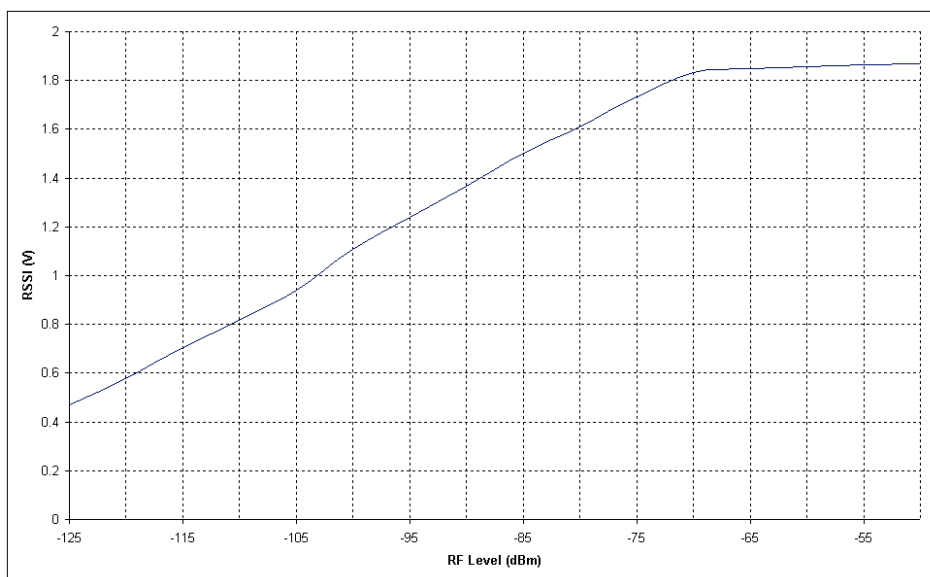

Figure 4: RSSI level with respect to received RF level at NiM2 antenna pin

Expected range

Predicting the range obtainable in any given situation is notoriously difficult since there are many factors involved. The main ones to consider are as follows:

- Type and location of antennas in use
- Type of terrain and degree of obstruction of the link path
- Sources of interference affecting the receiver
- “Dead” spots caused by signal reflections from nearby conductive objects
- Data rate and degree of filtering employed

Data formats and range extension

The NiM2 TXD input is normally driven directly by logic levels but will also accept analogue drive (e.g. 2-tone signalling). In this case it is recommended that TXD (pin 14) be DC-biased to 1.2V approx. with the modulation ac-coupled and limited to a maximum of $2V_{p-p}$ to minimise distortion over the link. The varactor modulator in the NiM2 introduces some 2nd harmonic distortion which may be reduced if necessary by predistortion of the analogue waveform. At the other end of the link the NiM2 RXD output is used to drive an external decoder directly.

Although the modulation bandwidth of the NiM2 extends down to DC it is not advisable to use data containing a DC component. This is because frequency errors and drifts between the transmitter and receiver occur in normal operation, resulting in DC offset errors on the NiM2 audio output.

The NiM2 in standard form incorporates a low pass filter with a 5kHz nominal bandwidth. This is suitable for transmission of data at raw bit rates up to 10kbps.

Antennas

The choice and positioning of transmitter and receiver antennas is of the utmost importance and is the single most significant factor in determining system range. The following notes are intended to assist the user in choosing the most effective antenna type for any given application.

The following types of integral antenna are in common use:

Quarter-wave whip. This consists simply of a piece of wire or rod connected to the module at one end. At 434MHz the total length should be 164mm from module pin to antenna tip including any interconnecting wire or tracking. Because of the length of this antenna it is almost always external to the product casing.

Helical. This is a more compact but slightly less effective antenna formed from a coil of wire. It is very efficient for its size, but because of its high Q it suffers badly from detuning caused by proximity to nearby conductive objects and needs to be carefully trimmed for best performance in a given situation. The size shown in figure 5 below is about the maximum commonly used at 433MHz and appropriate scaling of length, diameter and number of turns can make individual designs much smaller.

Loop. A loop of PCB track having an inside area as large as possible (minimum about 4cm^2), tuned and matched with 2 or 4 capacitors. Loops are relatively inefficient but have good immunity to proximity detuning, so may be preferred in shorter range applications where high component packing density is necessary.

Integral antenna summary:

Feature	whip	helical	loop
Ultimate performance	***	**	*
Ease of design set-up	***	**	*
Size	*	***	**
Immunity to proximity effects	**	*	***

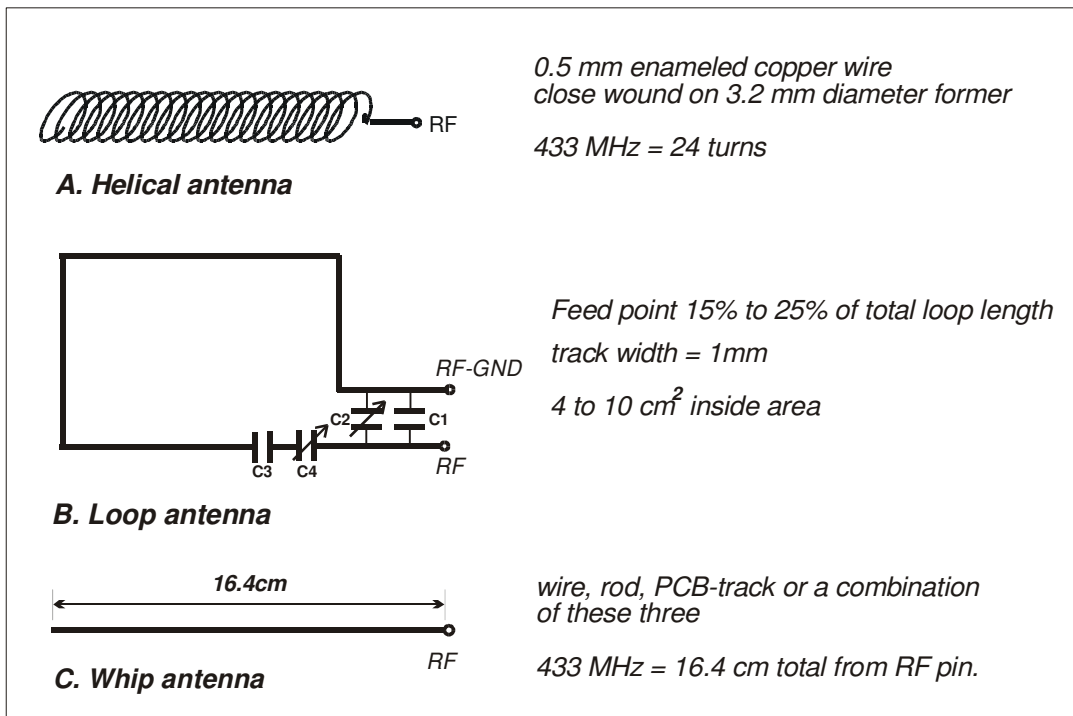

Figure 5: integral antenna configurations

Packet data

In general, data to be sent via a radio link is formed into a serial "packet" of the form :-

Preamble - Control - Address - Data - CRC

Where: **Preamble:** This is mandatory for the adaptive data slicer in the receiver in the NiM2 to stabilise. The NiM2 will be stable after 10ms. Additional preamble time may be desired for decoder bit synchronisation, firmware carrier detection or receiver wake up.

Control: The minimum requirement is a single bit or unique bit pattern to indicate the start of message (frame sync.). Additionally, decoder information is often placed here such as: packet count, byte count, flow control bits (e.g. ACK, repeat count), repeater control, scrambler information etc.

Address: This information is used for identification purposes and would at least contain a 16/24 bit source address, additionally - destination address, site / system code, unit number and repeater address's may be placed here.

Data: User data, generally limited to 256 bytes or less (very long packets should be avoided to minimise repeat overheads on CRC failure and channel hogging).

CRC: 16/24 Bit CRC or Checksum of control-address-data fields used by the decoder to verify the integrity of the packet.

The exact makeup of the packet depends upon the system requirements and may involve some complex air-traffic density statistics to optimise through-put in large networked systems.

Networks

NiM2's may be used in many different configurations from simple pair's to multi-node random access networks. The NiM2 is a single frequency device thus in a multi node system the signalling protocol must use Time Division Multiple Access (TDMA). In a TDMA network only one transmitter may be on at a time, 'clash' occurs when two or more transmitters are on at the same time and will often cause data loss at the receivers. TDMA networks may be configured in several ways - Synchronous (time slots), Polling (master-slave) or Random access (async packet switching e.g. X25). Networked NiM2's allow several techniques for range / reliability enhancement:

Store and forward Repeaters: If the operating protocol of the network is designed to allow data path control then data may be routed via intermediate nodes. The inclusion of a repeating function in the network protocol either via dedicated repeater/router nodes or simply utilising existing nodes allows limitless network expansion.

Spatial Diversity: In buildings multi-path signals create null spots in the coverage pattern as a result of signal cancellation. In master-slave networks it is cost effective to provide 2 NiM2's with separate antenna at the master station. The null spot patterns will be different for the two NiM2's. This technique 'fills in' the null spots, i.e. a handshake failure on the first NiM2 due to a signal null is likely to succeed on the 2nd NiM2.

"RS232" Serial data

It is possible to transmit "RS232" serial data directly at 600 to 9600bps baud between a pair of NiM2 transceivers in half duplex mode. The data must be "packetised" with no gaps between bytes. i.e. The data must be preceded by >10ms of preamble (55h or AAh) to allow the data slicer in the NiM2 to settle, followed by one 00h and one FFh bytes to allow the receive UART to lock, followed by a unique start of message byte, (01h), then the data bytes and finally terminated by a CRC or check sum. The receiver data slicer provides the best bit error rate performance on codes with a 50:50 mark:space average over a 5ms period, a string of FFh or 00h is a very asymmetric code and will give poor error rates where reception is marginal. Only 50:50 codes may be used at data rates above 1kbps.

We recommend 3 methods of improving mark:space ratio of serial codes, all 3 coding methods are suitable for transmission at 10kbps:-

- **Method 1 - Bit coding**

Bit rate , Max 10kbps , Min 250bps
Redundancy (per bit) 100% (Bi-phase)

Each bit to be sent is divided in half, the first half is the bit to be sent and the second half, it's compliment. Thus each bit has a guaranteed transition in the centre and a mark:space of 50:50. This is Bi-phase or Manchester coding and gives good results, however the 100% redundancy will give a true throughput of 5kbps.

Another variation of this code is to encode a '1' as a long bit with one transition and '0' as a short bit with two transition or vice versa. Each encoded bit starts with a guaranteed transition to reverse the voltage level even if stream of 00h/FFh is encoded. This is called Differential Manchester Encoding. This encoding method is easier to decode as the decoder has to sample encoded bit several times and if the sample value is more than 75% of a long bit period, then it is decoded as '1' and if there was transition then it is decoded as '0' or vice versa.

- **Method 2 - FEC coding**

Bit rate , Max 10kbps, Min 2.4kbps
Redundancy (per byte) 100%

Each byte is sent twice; true then it's logical compliment. e.g. even bytes are true and odd bytes are inverted. This preserves a 50:50 balance.

A refinement of this simple balancing method is to increase the stagger between the true and the inverted data streams and add parity to each byte. Thus the decoder may determine the integrity of each even byte received and on a parity failure select the subsequent inverted odd byte. The greater the stagger the higher the immunity to isolated burst errors.

Digitised analogue data

Linear operation of NiM2 transceivers will allow direct transfer of analogue data, however in many applications the distortion and low frequency roll off are too high (e.g. bio-medical data such as ECG). The use of delta modulation is an excellent solution for analogue data in the range 1Hz up to 4kHz with less than 1% distortion. A number of proprietary IC's such as Motorola's MC3517/8 provide CVSD Delta mod/demod on a single chip.

Where the signal bandwidth extends down to DC , such as strain gauges, level sensing, load cells etc. then Voltage to Frequency / Frequency to Voltage chips (such as Nat Semi LM331) provide a simple means of digitising.

Module mounting considerations

Good RF layout practice should be observed. If the connection between module and antenna is more than about 20mm long use 50Ω microstrip line or coax or a combination of both. It is desirable (but not essential) to fill all unused PCB area around the module with ground plane.

Variants and ordering information

The NiM2T transmitters, NiM2R receivers and NiM2 transceivers are manufactured in the following variants as standard:

At 434.650MHz:	NiM2-434.65-10	Transceiver
	NiM2T-434.65-10	Transmitter
	NiM2R-434.65-10	Receiver
At 434.075MHz:	NiM2-434.075-10	Transceiver
	NiM2T-434.075-10	Transmitter
	NiM2R-434.075-10	Receiver

Other frequency variants can be supplied to individual customer requirements in the 433MHz (European) licence exempt bands

Radiometrix Ltd

**Hartcran House
231 Kenton Lane
Harrow, Middlesex
HA3 8RP
ENGLAND**

Tel: +44 (0) 20 8909 9595

Fax: +44 (0) 20 8909 2233

sales@radiometrix.com

www.radiometrix.com

Copyright notice

This product data sheet is the original work and copyrighted property of Radiometrix Ltd. Reproduction in whole or in part must give clear acknowledgement to the copyright owner.

Limitation of liability

The information furnished by Radiometrix Ltd is believed to be accurate and reliable. Radiometrix Ltd reserves the right to make changes or improvements in the design, specification or manufacture of its subassembly products without notice. Radiometrix Ltd does not assume any liability arising from the application or use of any product or circuit described herein, nor for any infringements of patents or other rights of third parties which may result from the use of its products. This data sheet neither states nor implies warranty of any kind, including fitness for any particular application. These radio devices may be subject to radio interference and may not function as intended if interference is present. We do NOT recommend their use for life critical applications.

The Intrastat commodity code for all our modules is: 8542 6000

R&TTE Directive

After 7 April 2001 the manufacturer can only place finished product on the market under the provisions of the R&TTE Directive. Equipment within the scope of the R&TTE Directive may demonstrate compliance to the essential requirements specified in Article 3 of the Directive, as appropriate to the particular equipment.

Further details are available on The Office of Communications (Ofcom) web site:

<http://www.ofcom.org.uk/>

Information Requests

Ofcom

Riverside House

2a Southwark Bridge Road

London SE1 9HA

Tel: +44 (0)300 123 3333 or 020 7981 3040

Fax: +44 (0)20 7981 3333

information.requests@ofcom.org.uk

European Communications Office (ECO)

Pebblinghus

Nansensgade 19

DK 1366 Copenhagen

Tel. +45 33896300

Fax +45 33896330

ero@ero.dk

www.ero.dk
