

High power Multichannel 869MHz band Data Link

The FPL3 is a 9600baud half-duplex multi channel OEM radio modem with a power output of 400mW. FPL3 operates in the European 500mW 869.40 - 869.65MHz non-specific SRD sub-band. It is also available in the Indian licence free 865 - 867MHz band (General telemetry and RFID).



Figure 1: FPL3-866-9-IND

Features

- Conforms to ETSI EN 300 220-3 and EN 301 489-3
- Conforms to Indian low power requirements for 865 - 867 MHz band
- High performance PLL synthesizer
- +26dBm RF power output
- Serial modem baud rate at 9600bps (half-duplex)
- Addressable point-to-point
- Usable range over 3km
- Fully screened. Low profile
- Re-programmable via RS232 interface

Applications

- Asset tracking systems
- Industrial telemetry and telecommand
- High performance security system
- Fire alarms
- ROV control applications
- High speed data modems

Technical Summary

- Operating frequencies: 865 - 867MHz (India) or 868 - 870MHz (EU)
- Maximum of 8 channels (depends on band allocation and data rate)
- Transmit power: 400mW (+26dBm) nominal
- Supply range: +5V regulated
- Current consumption: 500mA (at 400mW output) transmit, 50mA receive
- Modulation: 16kbps bi-phase FSK
- Receiver sensitivity: -107dBm for <1% data errors
- Size: 67 x 30 x 12mm

FPL3 869MHz half-watt wideband radio modem

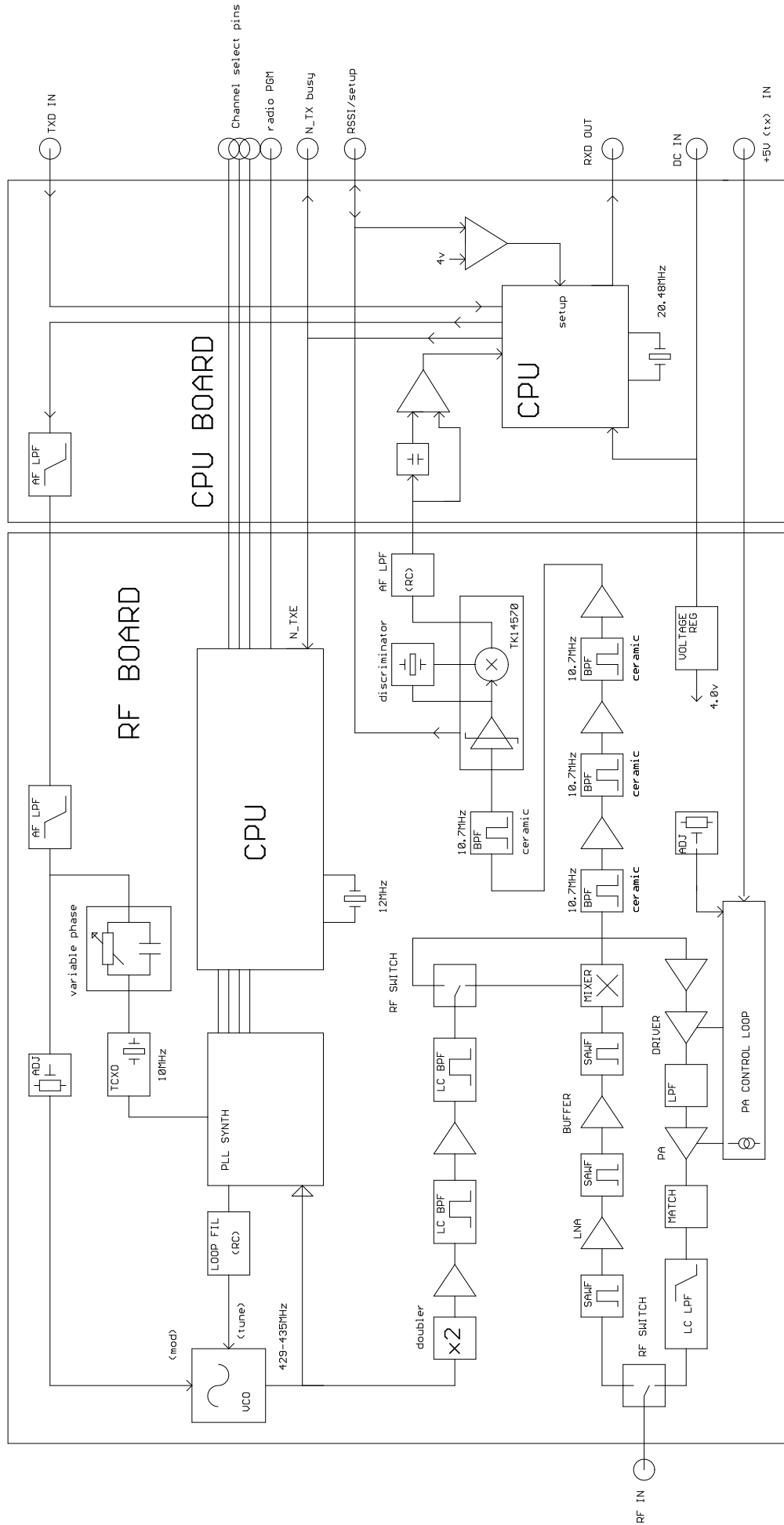

Figure 2: FPL3 block diagram

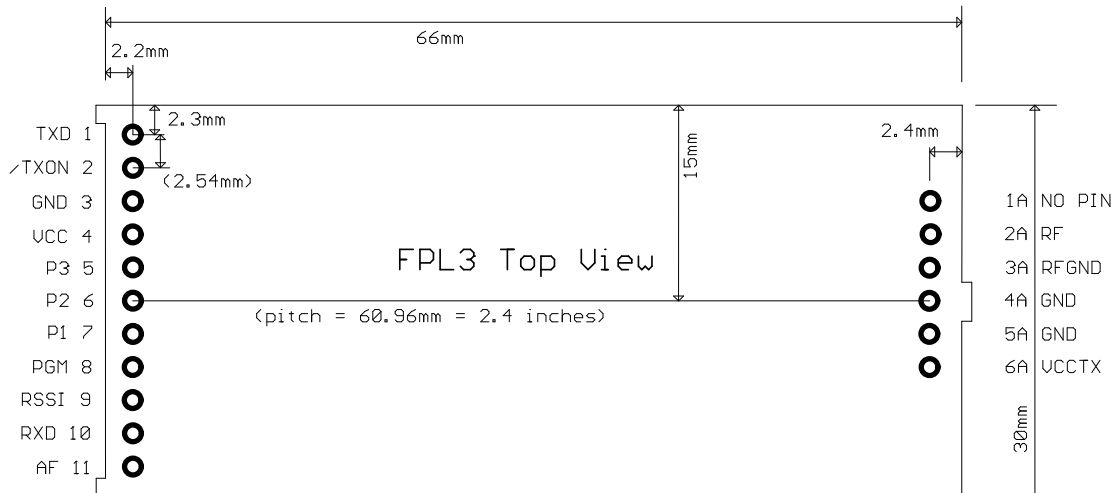

Figure 3: FPL3 footprint (Top) view

Pin Description

Pins		Normal mode
RF		
1A	NO PIN	
2A	RF in/out	To the antenna
3A	RF Gnd	RF ground
4A	GND	0V
5A	GND	0V
6A	Vcc (TX)	+5V regulated supply for TX ¹
User		
1	TXD	Transmit Data (Inverted RS232 at 5V CMOS logic level)
2	N_TX_ON	TX busy.
3	GND	0V
4	Vcc	DC supply input (+5V regulated) ¹
5	P3	Parallel channel select
6	P2	Parallel channel select
7	P1	Parallel channel select
8	PGM in	Serial programming/control input (inverted logic level RS232) for radio
9	RSSI out	DC level between 0.5V and 2.5V. 60dB dynamic range/ Modem program mode
10	RXD	Receive Data (Inverted RS232 at 5V CMOS logic level)
11	N/C	(RX AF output)

NOTES:

1. RXD and TXD are inverted "RS232" data streams (5v cmos levels) RXD has a 47K pullup to +5v
2. P1 - P3 (parallel channel selects) are active LOW and have internal 47K pullups to 4v
3. N_TX_ON (pin 2) is a logic output (logic 1 = 5v.)
(this is a high impedance pin. +/-100uA sink/source max)
4. The internal modem is compatible with the Radiometrix i9600 chip
It supports fully transparent 9600 baud (1+8+1) asynchronous data,
with a first byte in to first byte out latency of 14mS
5. The radio programming port (PGM) operates at 2400 baud. (Command set specific to this design).
The unit is capable of operating in 'basic' parallel channel select only mode, or in serial controlled
'expanded' mode
6. The i9600 chip can be put into program mode (to allow the address to be changed) by pulling
the RSSI pin up to 5V. Modem programming uses the main TXD pin, not the radio PGM pin
7. The high current (500mA maximum) transmitter supply (5v regulated) is fed to a separate pin, on the
RF out connector.
The V supply (pin 4 on the user connector) also requires a 5v regulated supply, and draws up to
50mA
Both pins must be supplied at all times (most users connect them to a common +5V supply)

Serial interface – Modem operation

To connect to a true RS232 device, inverting RS232-CMOS level shifters must be used. Maxim MAX232 or equivalent are ideal, but simple NPN transistor switches with pull-ups often suffice. With typical microcontrollers and UARTs, direct connection is possible.

The Radio / data stream interface

A 32 byte software FIFO is implemented in both the transmit and receive sub-routine. At the transmitting end this is used to allow for the transmitter start up time (about 5mS), while on receiving end it buffers arriving packets to the constant output data rate. All timing and data formatting tasks are handled by the internal firmware. The user need not worry about keying the transmitter before sending data as the link is entirely transparent.

For transmission across the radio link data is formatted into packets, each comprising 3 bytes of data and a sync code. If less than 3 bytes are in the transmit end FIFO then a packet is still sent, but idle codes replaces the unused bytes. When the transmit end FIFO is completely emptied, then the transmitter is keyed off. . A link latency (first byte in to tx to first byte out of rx) of 14mS is thus so achieved.

Raw data is not fed to the radios. A coding operation in the transmit sub-routine, and decoding in the receiver, isolate the AC coupled, potentially noisy baseband radio environment from the datastream.

The radio link is fed a continuous tone by the device. As in bi-phase codes, information is coded by varying the duration consecutive half-cycles of this tone. In our case half cycles of 62.5us and 31.25us are used. In idle (or 'preamble') state, a sequence of the longer cycles is sent (resembling an 8KHz tone).

A packet comprises the Synchronising (or address) part, followed by the Data part, made up of twelve Groups (of four half cycles duration). Each Group encodes 2 data bits, so one byte is encoded by 4 Groups.

Programming - Modem

The internal modem chip is programmed using the i9600 commands, at 9600 baud, through the TXD pin. The **RSSI** pin must be pulled up to 5v to enter modem programming mode

An RS232 terminal emulator (such as Aterm or HyperTerminal) is an ideal tool.

Terminal program configured with following setup:

9600baud, 1 start bit, 8 data bits, no parity, 1 or 2 stop bits

The unit will only respond to certain command strings:

ADDR0 to ADDR7 <CR>: These commands set up one of 8 unique addresses. An FPL3 will only communicate with a unit set to the same address.

Address is stored in volatile memory. On power-up the modem reverts to the default in EEPROM (as supplied this is always address 0)

SETPROGRAM <CR>: Writes the current address and current channel into EEPROM as the new default.
A tilda character (~, ascii 126dec) sent by the unit indicates end of EEPROM write sequence

(these commands are normally only used for factory diagnostics)

NOTONE <CR>: Transmit unmodulated carrier

LFTONE <CR>: Transmit carrier modulated with 8KHz squarewave

HFTONE <CR>: Transmit carrier modulated with 16KHz squarewave

<CR>: Transmitter off

A Carriage Return '<CR>' (00Dhex) should be entered after each command sequence to execute it.

Releasing the SETUP pin to high state returns the modem to normal operation.

Programming - Radio

The RF circuits have their own programming input

Serial data is sent to the unit on the programming input (PGM- pin 8).
To successfully program the unit, it must be powered

An RS232 terminal emulator (such as Aterm or HyperTerminal) is an ideal tool.
Terminal program configured with following setup:
2400baud, 1 start bit, 8 data bits, no parity, 1 or 2 stop bits

Serial interface commands

Unlike earlier Radiometrix multichannel units, the FPL3 has separate N and R registers for each channel, on transmit and on receive. In other words, the frequency of each channel is individually programmed in every mode.

Commands include:

Commands	Function
GOCHAN a	serial select of channel a (ch0 to 7)
SETPAR	channel selected by 3 bit parallel input
SETSER	channel selected by most recent 'gochan' operation
<cr>	process entry
/	clear all buffers
#	disable command mode

a = single digit channel number from 0 to 7

Most users will not need to edit the table which relates channel frequency, channel number and synthesizer register programming values. The commands below are used to access the eeprom table containing this information.

Users should be warned that, in order to get the optimum switching speed from the module, the standard channel setup uses a different reference frequency for each channel, and the absolute calculated channel frequency is allowed to deviate by up to +/-2KHz from the nominal

LOAD aa nnnnn (aa = 00 – 07)	set value of N for channel a , for receive
LOAD aa nnnnn (aa = 08 – 15)	set value of N for channel a , for transmit
LOAD aa rrrrr (aa = 16 – 23)	set value of R for channel a , for receive
LOAD aa rrrrr (aa = 24 – 31)	set value of R for channel a , for transmit

Reference frequency (10MHz/R) must be in the range 210 to 300KHz (tx) or 175 to 300KHz (rx).
As a rule of thumb, an R value greater than 45 (tx) or 55 (rx) should be viewed with suspicion.

aa = eeprom location number from 0 to 31
nnnnn = a synthesizer N register value, (up to 65535)
rrrrr = the synthesizer R register value, (up to 16383)

ALL COMMANDS MUST BE IN UPPER CASE.

Notice that the synthesizer and VCO operate at half the output frequency, so for a frequency of 869.475MHz, the actual N/R values will be set for 434.7375MHz

Further information TBA

NOTE:

- A pause of at least 50mS must be allowed between command strings (eeprom programming time)

Condensed specifications (All details are provisional)

Frequency	868 – 870MHz (EU), 865 - 867MHz (India)	
Frequency stability	+/-5ppm (better than ±5kHz)	
Channel spacing	125kHz	
Number of channels	8 maximum In the EU version 2 usable CH0 869.475MHz CH1 869.565MHz (also CH2-3) (Chan 4-7 are programmed for 869.50MHz, for backward compatibility)	
	In Indian allocation, 8 usable channels CH0 = 865.143 MHz CH1 = 865.294 MHz CH2 = 865.500 MHz CH3 = 865.789 MHz CH4 = 866.047 MHz CH5 = 866.383 MHz CH6 = 866.531 MHz CH7 = 866.829 MHz	
Supply	Receive	5.0V regulated at 50mA
	Transmit:	5.0V regulated at 500mA for 400mW output
Operating temperature	-20 to +70 °C (Storage -30 to +70 °C)	
Spurious radiations	Compliant with ETSI EN 300 220-3 and EN 301 489-3 (EU)	
Interface		
	User	11 pin 0.1" pitch molex
	RF and TX supply	5 pin 0.1" pitch molex
Recommended PCB hole size	1.2mm (min.)	
Size	67 x 30 x 12mm	
Transmitter		
Output power	400mW (+26dBm)	
TX on switching time	5 ms	
Modulation type	FSK	
TX modulation	16kbps biphase	
Deviation	±14kHz nominal	
Adjacent channel TX power	-37dBm	
TX spuri	<-36dBm	
Inputs	5V pk-pk CMOS data	
Receiver		
Sensitivity	-107dBm for <1% data errors	
image / spurious	-55dB	
blocking	-80dB	
adjacent channel	-60dB (Tested per. ETSI 300-220-2.3.1)	
Interface	RSSI, TXD, RXD, TX_ON	

Ordering Information

Part No.	Description	Frequency band (MHz)
FPL3-869-9	EU version	CH0:869.475MHz, CH1-CH3:869.565MHz, CH4-CH7:869.50MHz
FPL3-866-9-IND	Indian version	CH0:865.143MHz - CH7:866.829MHz

CEPT/ERC Rec 70-03, 868 MHz Band Plan

Applications	Non-specific SRD	Alarm	Non-specific SRD	Social Alarm	Alarm	Non-specific SRD	Alarm	Non-specific SRD
Channel Spacing	No Spacing	25kHz or WB	No Spacing	25kHz	25kHz	25kHz or Wide Band	25kHz	No Spacing
Duty Cycle	<1% or LBT	<1%	<0.1% or LBT	<0.1%	<1%	<10% or LBT	<10%	up to 100%

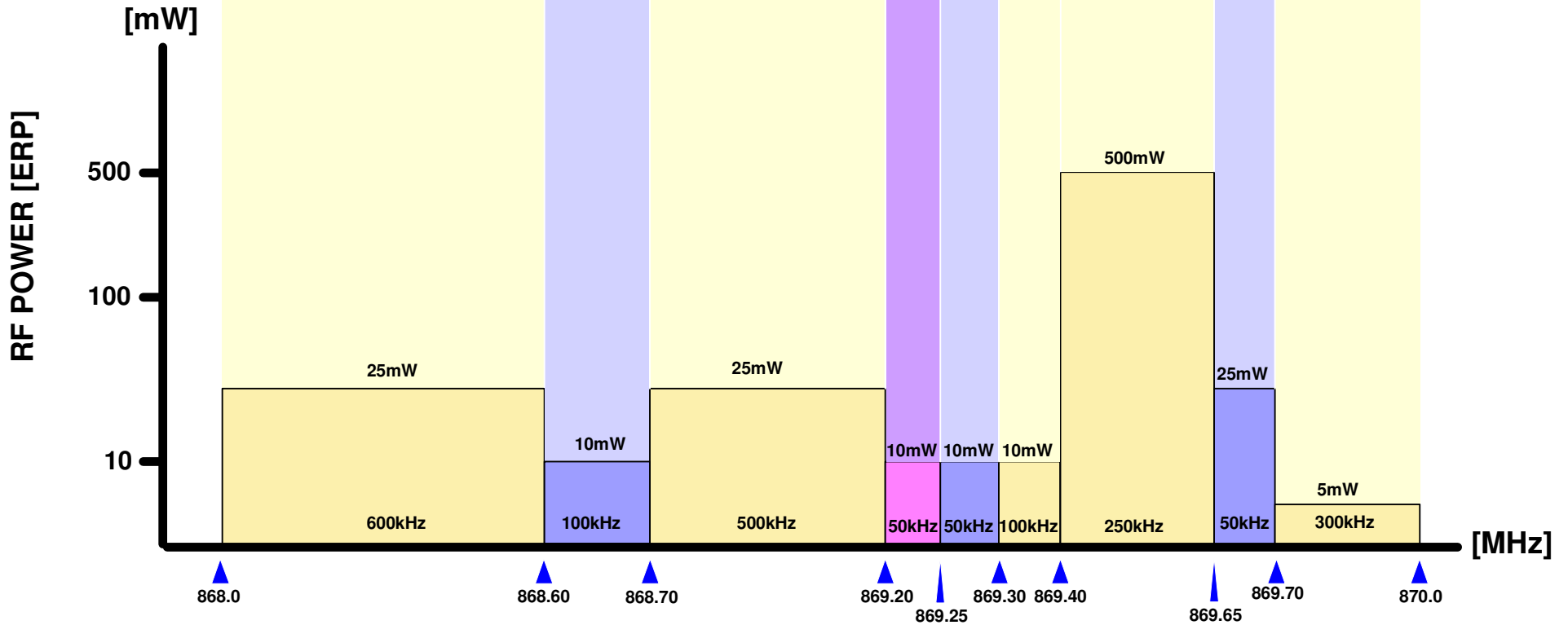

Radiometrix Ltd

**Hartcran House
231 Kenton Lane
Harrow, Middlesex
HA3 8RP
ENGLAND**

**Tel: +44 (0) 20 8909 9595
Fax: +44 (0) 20 8909 2233
sales@radiometrix.com
www.radiometrix.com**

Copyright notice

This product data sheet is the original work and copyrighted property of Radiometrix Ltd. Reproduction in whole or in part must give clear acknowledgement to the copyright owner.

Limitation of liability

The information furnished by Radiometrix Ltd is believed to be accurate and reliable. Radiometrix Ltd reserves the right to make changes or improvements in the design, specification or manufacture of its subassembly products without notice. Radiometrix Ltd does not assume any liability arising from the application or use of any product or circuit described herein, nor for any infringements of patents or other rights of third parties which may result from the use of its products. This data sheet neither states nor implies warranty of any kind, including fitness for any particular application. These radio devices may be subject to radio interference and may not function as intended if interference is present. We do NOT recommend their use for life critical applications.

The Intrastat commodity code for all our modules is: 8542 6000

R&TTE Directive

After 7 April 2001 the manufacturer can only place finished product on the market under the provisions of the R&TTE Directive. Equipment within the scope of the R&TTE Directive may demonstrate compliance to the essential requirements specified in Article 3 of the Directive, as appropriate to the particular equipment.

Further details are available on The Office of Communications (Ofcom) web site:

<http://www.ofcom.org.uk/>

Information Requests

Ofcom

Riverside House

2a Southwark Bridge Road

London SE1 9HA

Tel: +44 (0)300 123 3333 or 020 7981 3040

Fax: +44 (0)20 7981 3333

information.requests@ofcom.org.uk

European Communications Office (ECO)

Pebblinghus

Nansensgade 19

DK 1366 Copenhagen

Tel. +45 33896300

Fax +45 33896330

ero@ero.dk

www.ero.dk
