

Low Cost Narrow Band VHF receiver

The CVR1 receiver module offers a low cost, low current, reliable VHF data link in a Radiometrix BiM standard pin out and footprint. CVR1 is compatible with the Radiometrix TX1, HX1 and BiM1TH transmitters.

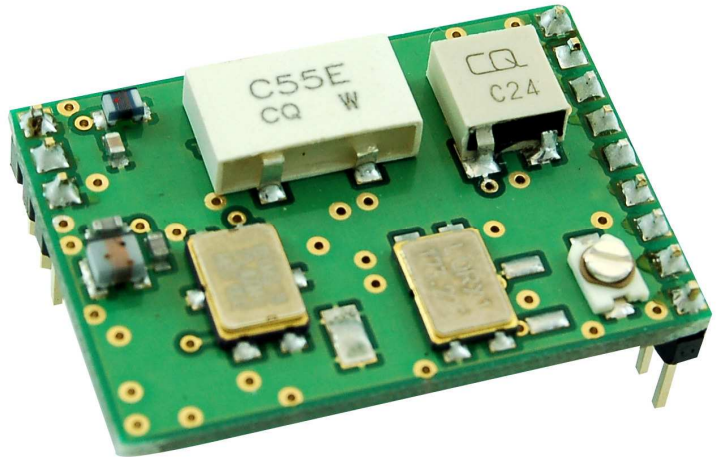

Figure 1: CVR1-169.4125-10 receiver (top)

Features

- ◆ Conforms to EN 300 220-3 and EN 301 489-3
- ◆ Frequencies: 144.390, 144.800, 149.170, 167.790, 169.4125, 173.225, 173.250MHz
- ◆ Other frequencies from 120MHz to 180MHz
- ◆ Data rates up to 10 kbps for standard module
- ◆ Feature-rich interface (RSSI, analogue and digital baseband)
- ◆ Low current consumption
- ◆ Long battery life

CVR1 is the cut down version of standard BiMIR receiver and lacks internal supply regulator and screening. Although CVR1 is made available for low end wireless applications where the cost is also a concern, its RF performance is not compromised.

Applications

- ◆ Solar powered remote installation
- ◆ Data loggers
- ◆ Industrial telemetry and telecommand
- ◆ In-building environmental monitoring and control
- ◆ Security and fire alarms

Technical Summary

- ◆ Size: 33 x 23 x 8mm
- ◆ Supply: 3V DC (regulated)
- ◆ Current consumption: 7mA
- ◆ Data bit rate: 10kbps max.
- ◆ Receiver sensitivity: -120dBm (for 12 dB SINAD)

CVR1

Single channel VHF receiver

$$F_{xtal} (RX) = (F_{chan} - 21.4MHz) \times 0.5$$

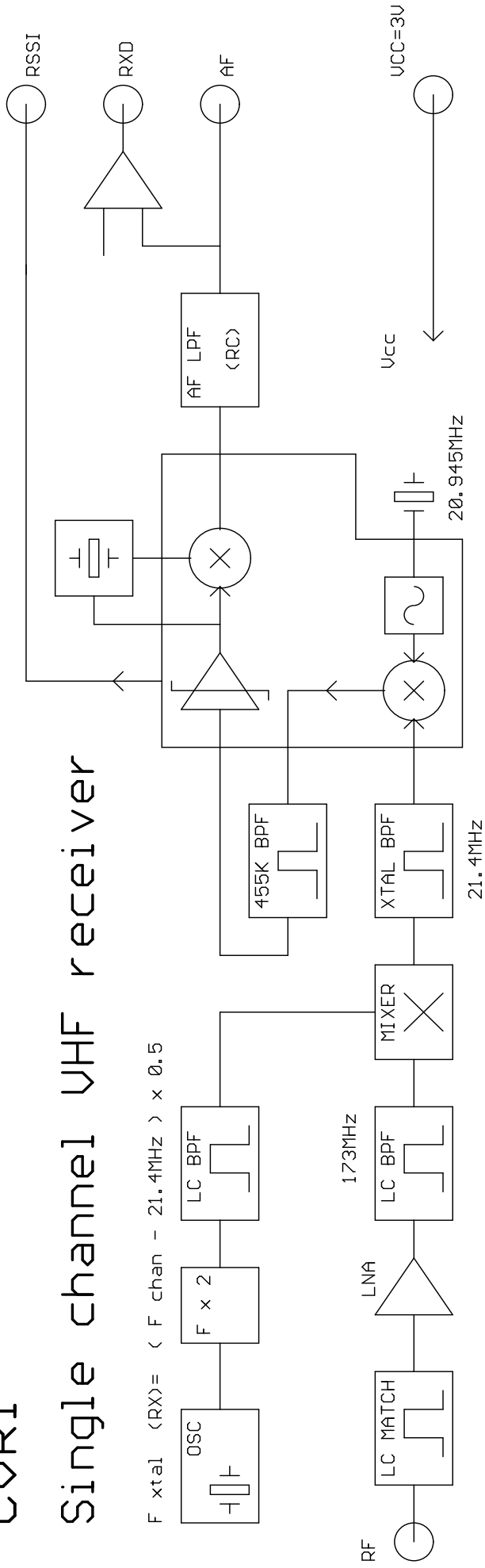

Figure 2: CVR1 block diagram

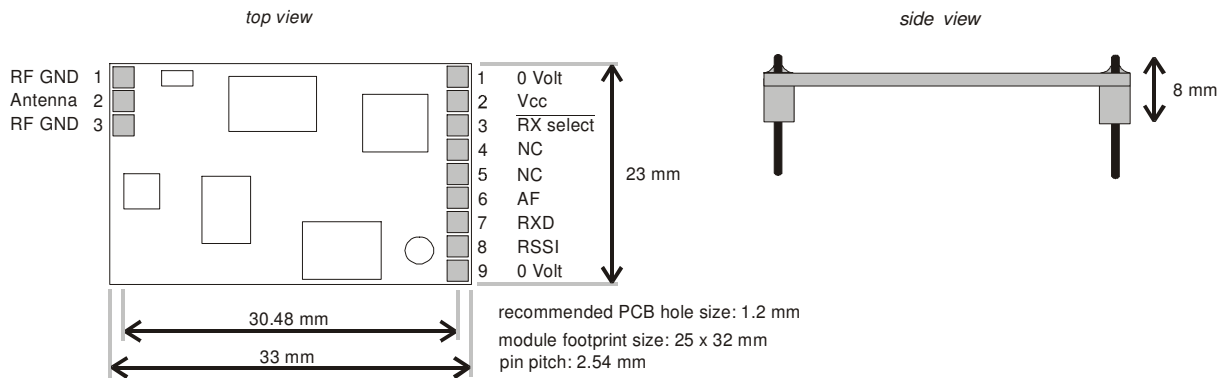

Figure 3: Pin-out and dimension

CVR1	Name	Function
1	0V	Ground
2	VCC	3.0V regulated DC power supply
3	$\overline{\text{RX SELECT}}$	Pull low to enable Receiver
4	NC	No connection
5	NC	No connection
6	AF	500mV _{pk-pk} audio. DC coupled, approx 0.8V bias
7	RXD	2.5V _{pk-pk} logic output of data slicer. Suitable for Biphase codes
8	RSSI	DC level between 0.5V and 2V. 60dB dynamic range
9	0V	Ground

NOTES:

1. RX SELECT and RXD have internal (10k Ω approx.) pull-up to Vcc
3. Pin out is as CVR1. On RF connector end only pins 1, 2, 3 are present.

Condensed specifications

Frequencies	144.390, 144.800, 149.170, 167.790, 169.4125, 173.225, 173.250MHz Other VHF 120-180MHz by special order
<i>Frequency stability</i>	+/- 2.5kHz
<i>Channel spacing</i>	25kHz
<i>Number of channels</i>	1
Supply <i>voltage</i>	3V (+/- 10%)
<i>Current</i>	7mA receive
Operating temperature	-10°C to +60°C (Storage -30°C to +70°C)
Size	33mm x 23mm x 8mm
Spurious radiations	Compliant with ETSI EN 300 220-3 and EN 301 489-3
Interface	
<i>User</i>	9pin 0.1" pitch molex
<i>RF</i>	3pin 0.1" pitch molex
Sensitivity	-120dBm for 12 dB SINAD
image / spurious	-60dB or better
Blocking	-85dB or better
adjacent channel	-65dB
LO re-rad	<-65dBm
Outputs	RSSI, data, AF

Applications information

RX Received Signal Strength Indicator (RSSI)

The CVR1 has a wide range RSSI which measures the strength of an incoming signal over a range of 60dB or more. This allows assessment of link quality and available margin and is useful when performing range tests.

The output on pin 11 of the module has a standing DC bias of up to 0.5V with no signal, rising to 2.4V at maximum indication. $\Delta V_{\text{min-max}}$ is typically 1V and is largely independent of standing bias variations. Output impedance is 56k Ω . Pin 11 can drive a 100 μ A meter directly, for simple monitoring.

Typical RSSI characteristic is as shown below:

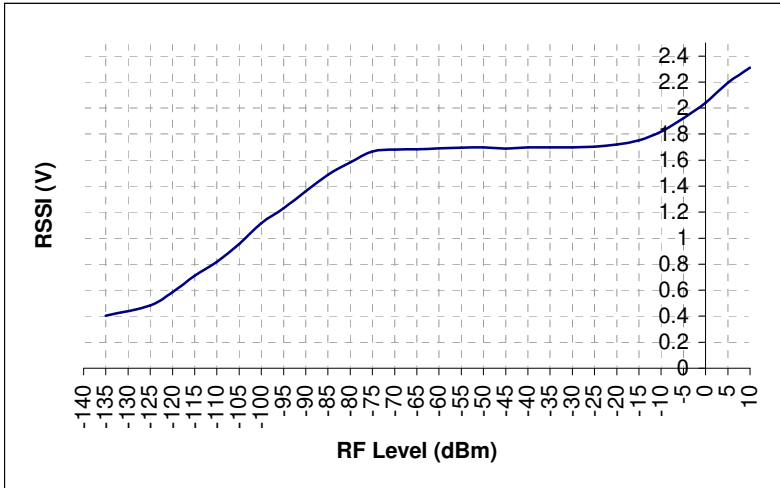

Figure 4: RSSI level with respect to received RF level at CVR1 antenna pin

Packet data

In general, data to be sent via a radio link is formed into a serial "packet" of the form :-

Preamble - Control - Address - Data - CRC

Where: Preamble: This is mandatory for the adaptive data slicer in the receiver in the CVR1 to stabilise. The CVR1 will be stable after 10ms. Additional preamble time may be desired for decoder bit synchronisation, firmware carrier detection or receiver wake up.

Control: The minimum requirement is a single bit or unique bit pattern to indicate the start of message (frame sync.). Additionally, decoder information is often placed here such as: packet count, byte count, flow control bits (e.g. ACK, repeat count), repeater control, scrambler information etc.

Address: This information is used for identification purposes and would at least contain a 16/24 bit source address, additionally - destination address, site / system code, unit number and repeater address's may be placed here.

Data: User data, generally limited to 256 bytes or less (very long packets should be avoided to minimise repeat overheads on CRC failure and channel hogging).

CRC: 16/24 Bit CRC or Checksum of control-address-data fields used by the decoder to verify the integrity of the packet.

The exact makeup of the packet depends upon the system requirements and may involve some complex air-traffic density statistics to optimise through-put in large networked systems.

Antennas

The choice and positioning of transmitter and receiver antennas is of the utmost importance and is the single most significant factor in determining system range. The following notes are intended to assist the user in choosing the most effective antenna type for any given application.

Integral antennas

These are relatively inefficient compared to the larger externally-mounted types and hence tend to be effective only over limited ranges. They do however result in physically compact equipment and for this reason are often preferred for portable applications. Particular care is required with this type of antenna to achieve optimum results and the following should be taken into account:

1. Nearby conducting objects such as a PCB or battery can cause detuning or screening of the antenna which severely reduces efficiency. Ideally the antenna should stick out from the top of the product and be entirely in the clear, however this is often not desirable for practical/ergonomic reasons and a compromise may need to be reached. If an internal antenna must be used try to keep it away from other metal components and pay particular attention to the “hot” end (i.e. the far end) as this is generally the most susceptible to detuning. The space around the antenna is as important as the antenna itself.
2. Microprocessors and microcontrollers tend to radiate significant amounts of radio frequency hash which can cause desensitisation of the receiver if its antenna is in close proximity. The problem becomes worse as logic speeds increase, because fast logic edges generate harmonics across the VHF range which are then radiated effectively by the PCB tracking. In extreme cases system range may be reduced by a factor of 5 or more. To minimise any adverse effects situate antenna and module as far as possible from any such circuitry and keep PCB track lengths to the minimum possible. A ground plane can be highly effective in cutting radiated interference and its use is strongly recommended.

A simple test for interference is to monitor the receiver RSSI output voltage, which should be the same regardless of whether the microcontroller or other logic circuitry is running or in reset.

The following types of integral antenna are in common use:

Quarter-wave whip. This consists simply of a piece of wire or rod connected to the module at one end. At 173MHz the total length should be 410mm from module pin to antenna tip including any interconnecting wire or tracking. Because of the length of this antenna it is almost always external to the product casing.

Helical. This is a more compact but slightly less effective antenna formed from a coil of wire. It is very efficient for its size, but because of its high Q it suffers badly from detuning caused by proximity to nearby conductive objects and needs to be carefully trimmed for best performance in a given situation. The size shown is about the maximum commonly used at 173MHz and appropriate scaling of length, diameter and number of turns can make individual designs much smaller.

Loop. A loop of PCB track having an inside area as large as possible (minimum about 5cm²), tuned and matched with 2 capacitors. Loops are relatively inefficient but have good immunity to proximity detuning, so may be preferred in shorter range applications where high component packing density is necessary.

Integral antenna summary:

	whip	helical	loop
Ultimate performance	***	**	*
Ease of design set-up	***	**	*
Size	*	***	**
Immunity to proximity effects	**	*	***

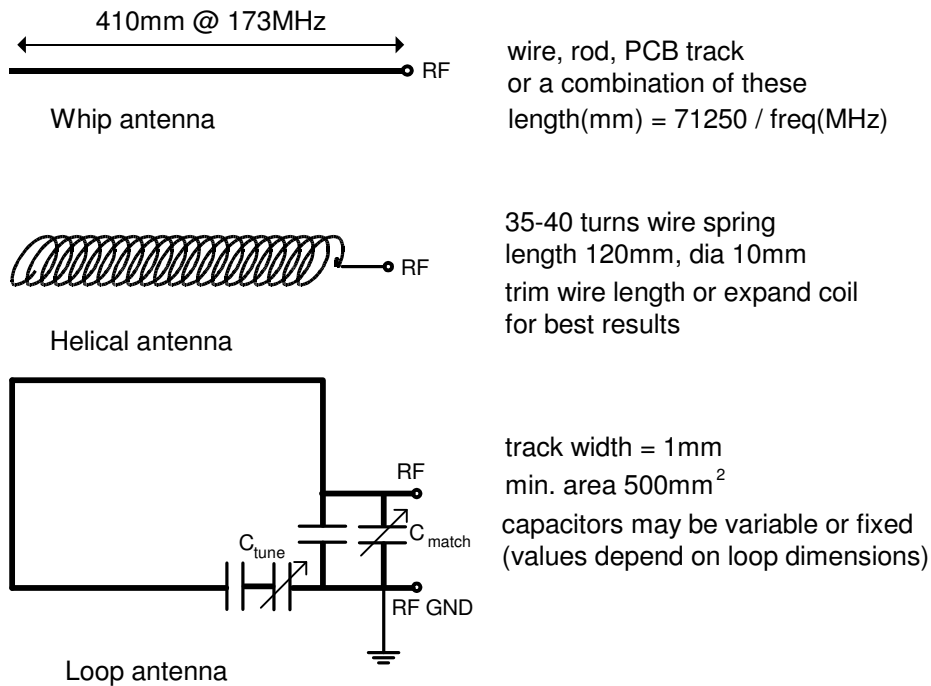

Figure 5: integral antenna configurations

External antennas

These have several advantages if portability is not an issue, and are essential for long range links. External antennas can be optimised for individual circumstances and may be mounted in relatively good RF locations away from sources of interference, being connected to the equipment by coax feeder.

Helical. Of similar dimensions and performance to the integral type mentioned above, commercially-available helical antennas normally have the coil element protected by a plastic moulding or sleeve and incorporate a coax connector at one end (usually a straight or right-angle BNC type). These are compact and simple to use as they come pre-tuned for a given application, but are relatively inefficient and are best suited to shorter ranges.

Quarter-wave whip. Again similar to the integral type, the element usually consists of a stainless steel rod or a wire contained within a semi-flexible moulded plastic jacket. Various mounting options are available, from a simple BNC connector to wall brackets, through-panel fixings and magnetic mounts for temporary attachment to steel surfaces.

Ground plane

A significant improvement in performance is obtainable if the whip is used in conjunction with a metal ground plane. For best results this should extend all round the base of the whip out to a radius of 300mm or more (under these conditions performance approaches that of a half-wave dipole) but even relatively small metal areas will produce a worthwhile improvement over the whip alone. The ground plane should be electrically connected to the coax outer at the base of the whip. Magnetic mounts are slightly different in that they rely on capacitance between the mount and the metal surface to achieve the same result.

As shown on figure 9, a ground plane can also be simulated by using 3 or 4 quarter-wave radials equally spaced around the base of the whip, connected at their inner ends to the outer of the coax feed. A better match to a 50Ω coax feed can be achieved if the elements are angled downwards at approximately 30-40° to the horizontal.

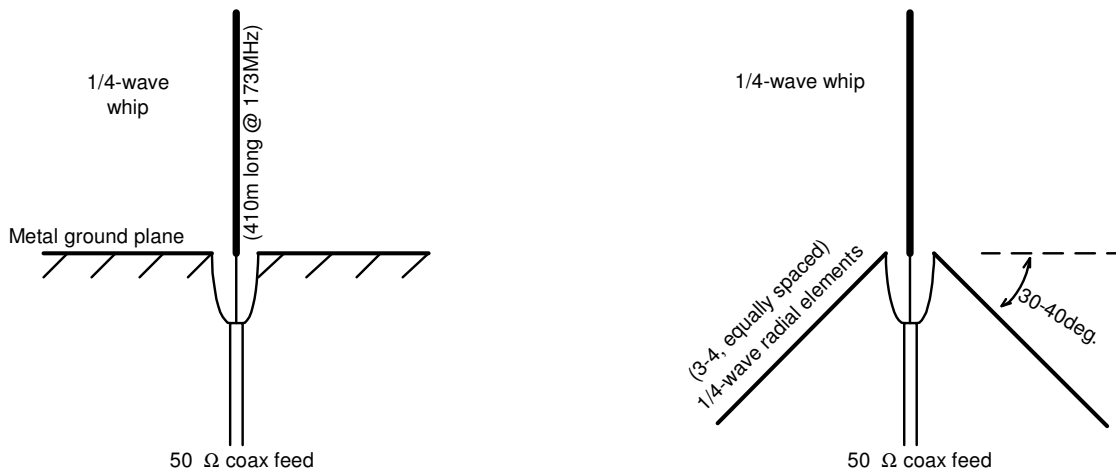

Figure 6: Quarter wave antenna / ground plane configurations

Half-wave. There are two main variants of this antenna, both of which are very effective and are recommended where long range and all-round coverage are required:

1. The half-wave dipole consists of two quarter-wave whips mounted in line vertically and fed in the centre with coaxial cable. The bottom whip takes the place of the ground plane described previously. A variant is available using a helical instead of a whip for the lower element, giving similar performance with reduced overall length. This antenna is suitable for mounting on walls etc. but for best results should be kept well clear of surrounding conductive objects and structures (ideally >1m separation).
2. The end-fed half wave is the same length as the dipole but consists of a single rod or whip fed at the bottom via a matching network. Mounting options are similar to those for the quarter-wave whip. A ground plane is sometimes used but is not essential. The end-fed arrangement is often preferred over the centre-fed dipole because it is easier to mount in the clear and above surrounding obstructions.

Yagi. This antenna consists of two or more elements mounted parallel to each other on a central boom. It is directional and exhibits gain but tends to be large and unwieldy – for these reasons the yagi is the ideal choice for links over fixed paths where maximum range is desired.

For best range in UK fixed link applications use a half-wave antenna on the matching transmitter (e.g. TX1, BiM1T) and a half-wave or Yagi on CVR1 receiver, both mounted as high as possible and clear of obstructions.

Module mounting considerations

Good RF layout practice should be observed. If the connection between module and antenna is more than about 20mm long use 50Ω microstrip line or coax or a combination of both. It is desirable (but not essential) to fill all unused PCB area around the module with ground plane.

Variants and ordering information

The CVR1 receiver is manufactured in the following variants as standard:

CVR1-144.390-10	APRS in North America
CVR1-144.800-10	APRS in Europe
CVR1-149.170-10	Special Service of Supervision and Control in Brazil
CVR1-167.790-10	Special Service of Supervision and Control in Brazil
CVR1-169.4125-10	Meter Reading, Asset Tracking and Tracing in Europe
Matching transmitter:	HX1-169.4125-3
	TX1-169.4125-10
CVR1-173.225-10	Fixed Alarms in UK
Matching transmitter:	TX1-173.225-10
CVR1-173.250-10	Industrial/Commercial Telemetry and Telecommand in UK
Matching transmitter:	TX1-173.250-10

Radiometrix Ltd

Hartcran House
231 Kenton Lane
Harrow, Middlesex
HA3 8RP
ENGLAND
Tel: +44 (0) 20 8909 9595
Fax: +44 (0) 20 8909 2233
sales@radiometrix.com
www.radiometrix.com

Copyright notice

This product data sheet is the original work and copyrighted property of Radiometrix Ltd. Reproduction in whole or in part must give clear acknowledgement to the copyright owner.

Limitation of liability

The information furnished by Radiometrix Ltd is believed to be accurate and reliable. Radiometrix Ltd reserves the right to make changes or improvements in the design, specification or manufacture of its subassembly products without notice. Radiometrix Ltd does not assume any liability arising from the application or use of any product or circuit described herein, nor for any infringements of patents or other rights of third parties which may result from the use of its products. This data sheet neither states nor implies warranty of any kind, including fitness for any particular application. These radio devices may be subject to radio interference and may not function as intended if interference is present. We do NOT recommend their use for life critical applications.

The Intrastat commodity code for all our modules is: 8542 6000

R&TTE Directive

After 7 April 2001 the manufacturer can only place finished product on the market under the provisions of the R&TTE Directive. Equipment within the scope of the R&TTE Directive may demonstrate compliance to the essential requirements specified in Article 3 of the Directive, as appropriate to the particular equipment.

Further details are available on The Office of Communications (Ofcom) web site:

<http://www.ofcom.org.uk/>

Information Requests
Ofcom
Riverside House
2a Southwark Bridge Road
London SE1 9HA
Tel: +44 (0)300 123 3333 or 020 7981 3040
Fax: +44 (0)20 7981 3333
information.requests@ofcom.org.uk

European Communications Office (ECO)
Peblingehus
Nansensgade 19
DK 1366 Copenhagen
Tel. +45 33896300
Fax +45 33896330
ero@ero.dk
www.ero.dk