

Radiometrix

Hartcran House, 231 Kenton Lane, Harrow, HA3 8RP, England

Issue: 2, 13 February 2007

Tel: +44 (0) 20 8909 9595. Fax: +44 (0) 20 8909 2233

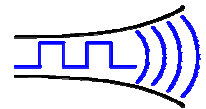

Control124

4 bit Address - 12 bit Data encoder/decoder

Control124 is a 4 bit address, 12 bit data encoder and decoder combined in a single IC. This device can operate in either Encode or Decode mode. It uses 1kbps differential Manchester bit balancing with preamble and checksum. CTR124 is specifically designed to be used in RF remote control applications. It is available in 28pin SO and DIL packages.

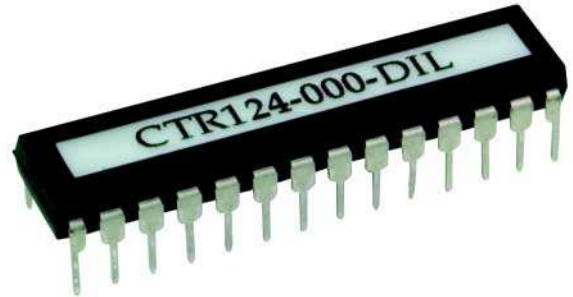

Figure 1: Control124 in 28 pin DIL package

Features

- Operating voltage (temperature):
 - 4.0V-5.5V for standard version (-40°C to +125°C)
 - 2.0V-5.5V for low voltage version (-40°C to +85°C)
- Draws <2mA without external load
- 4 bit address and 12 bit data
- 16 different remotes with 12 controls each
- Single packetised transmission for fast activation
- Maximum usage of the range capability of an RF module
- Adequate preamble to settle data slicer in the receiver.
- Extra wake up preamble to allow for transmitter power up time requirements
- Differential Manchester encoding of address, data and checksum
- Synchronisation codes and checksum to reduce false triggering on noise
- Suitable to be used with Narrow Band FM radio modules
- Ceramic resonator or crystal oscillator up to 20MHz
- Data rate up to 5.6kbps
- Minimum external component requirement
- 4 wire, push button and latched push button modes
- Custom address, data bit variations available subject to minimum order quantity

Applications

- Security and Alarm systems
- Emergency assistance call system
- Status reporting and monitoring systems
- RF Remote control systems
- Industrial controls
- HVAC controls
- Simple On/Off switching
- Long range telecontrol with Narrow Band FM radios

Encoder Mode

Control124 can be put into Encoder Mode by connecting Mode (pin 2) to supply.

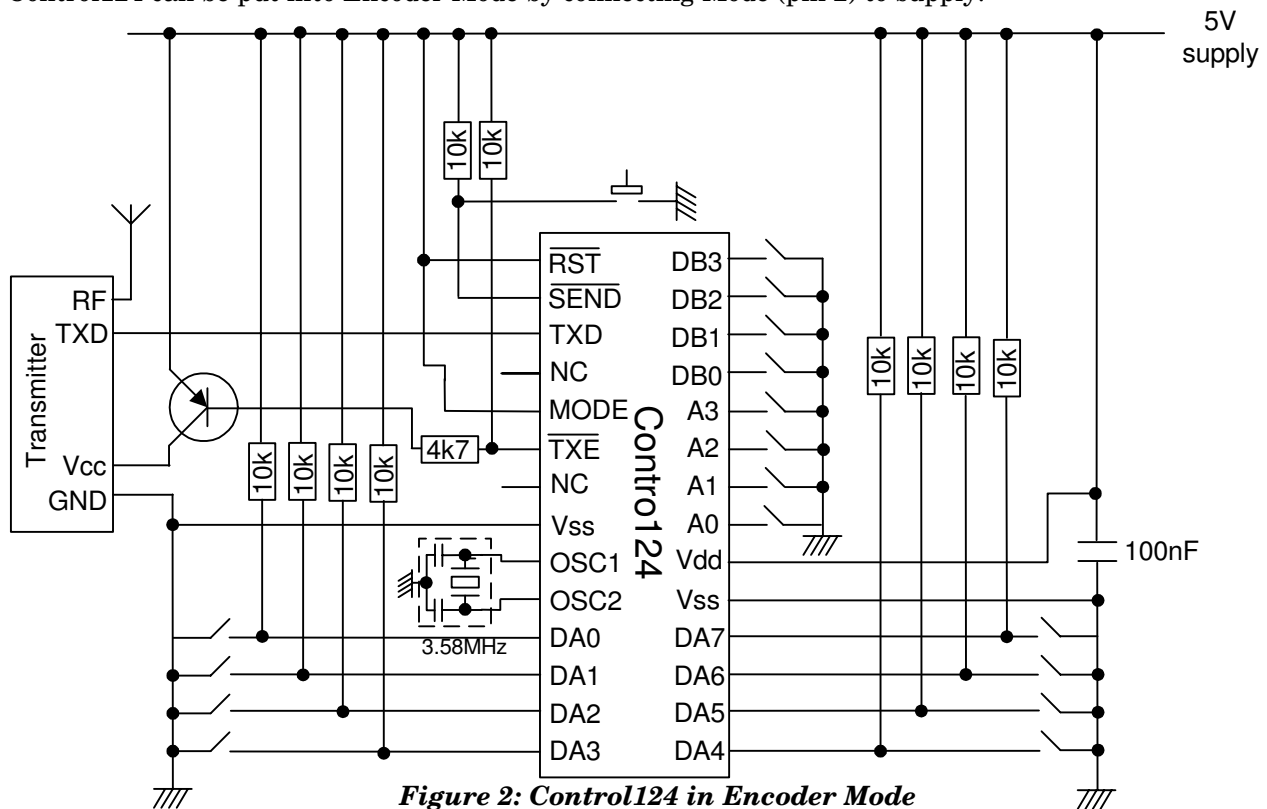

Figure 2: Control124 in Encoder Mode

Pin	Name	Input/Output	Description
1	RST	Input	Active Low Reset (Connect to user system reset or tie to Vdd)
2	SEND	Input	Active Low Send Packet (Encoder Enable) ¹
3	TXD	Output	Encoded Address and Data to TXD input of RF Transmitter
4	NC	-	-
5	MODE	Input	RX=0V, TX=Vdd (no pull-up, only read at reset/power up)
6	TXE	Output	Active Low RF Transmitter Enable (Open drain, require 10k pull-up) ^{2,3}
7	NC	-	-
8	VSS	Supply	Supply Ground
9	OSC2	Output	3.58MHz resonator ⁴
10	OSC1	Input	3.58MHz resonator ⁴
11 - 18	DA0 - DA7	Input	8 bits of Data A; Schmitt trigger input ^{5, 6}
19	VSS	Supply	Supply Ground
20	VDD	Supply	4.0V-5.5V supply (decouple with 100nF close to IC). 2.0V-5.5V (low voltage version)
21 - 24	A0 - A3	Input	Least significant 4 bits of Address (Internal pull-ups to Vdd) ⁶
25 - 28	DB0 - DB3	Input	Least significant 4 bits of Data B (Internal pull-ups to Vdd) ⁶

Notes:

1. If a low going pulse of between 10 μ s and 50ms is applied to SEND pin then a single packet will be transmitted
2. After asserting TXE low (active), the encoder allows 55ms for NBFM TX to power up and settle
3. TXE is an open drain output (no pull-up). Connect it to Vdd via a 10k Ω pull-up resistor
4. OSC1,2 require a 3.58MHz ceramic resonator with internal capacitors like Murata CSTLA3M58G55-B0. If a 2 pin resonator or crystal is used, then two 15pF-22pF caps are needed: one from OSC1 to 0V another from OSC2 to 0V. 100 Ω series resistor between OSC2 and crystal may be required when driving low frequency crystal with High Speed (H) CTR124H version.
5. Not suitable for non-standard logic levels, require external pullup resistors.
6. Absolute maximum source/sink current from each DA0-DA7, DB0-DB3 and A0-A3 pins is 25mA. Absolute maximum total current from DA0-DA7 port and DB0-DB3, A0-A3 port is 200mA
7. MODE pin is only read at reset/power up. Connect to either Vdd (Encoder) or 0V (Decoder).
8. Without external loads the CTR124 draws <2mA from 5V supply
9. Standard version can be used down to 4V for <20MHz oscillator.
Low voltage version can be used down to 2V for <4MHz oscillator

Decoder Mode

Control124 can be put into Decoder Mode by connecting Mode (pin 2) to Ground.

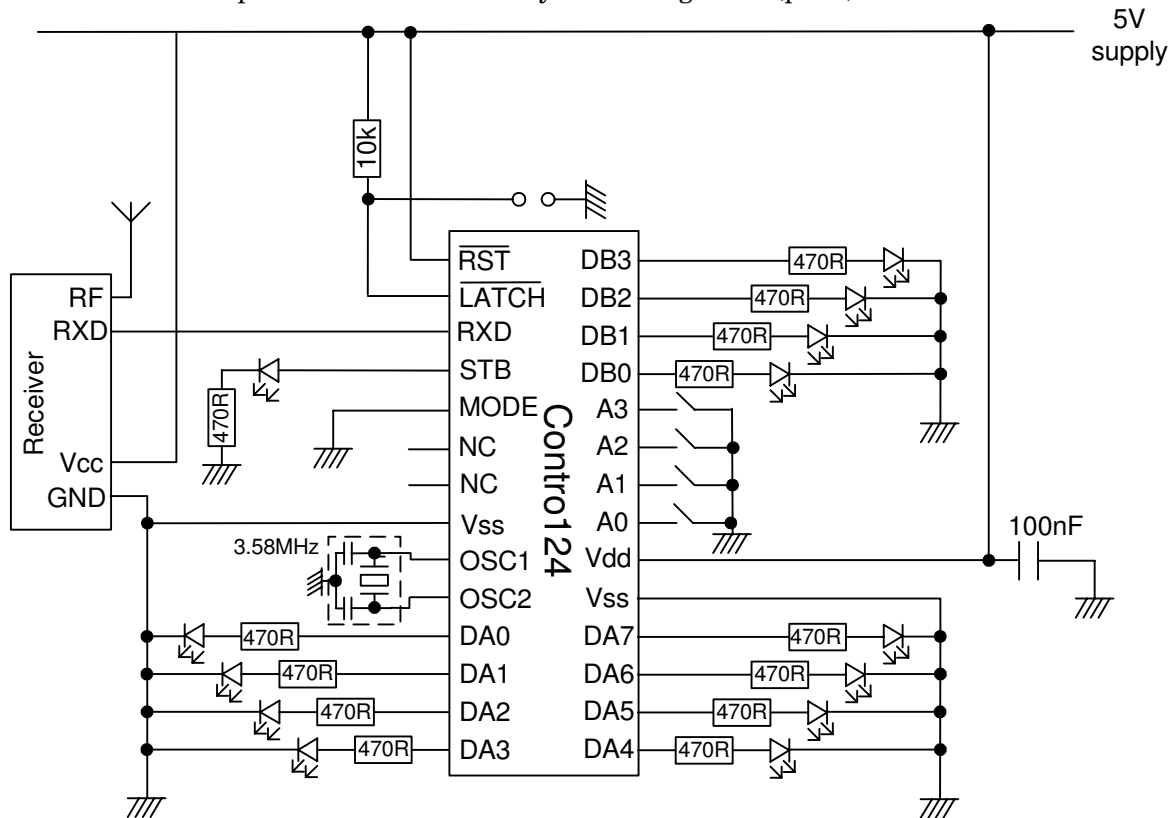

Figure 3: Control124 in Decoder Mode

Pin	Name	Input/Output	Description
1	RST	Input	Active Low Reset (Connect to user system reset or tie to Vdd)
2	LATCH	Input	0V = latch DA3:DA0 until next packet Vdd = clear DA3:DA0 after 150ms (no pull-up)
3	RXD	Input	Encoded Address and Data from RXD Output of RF Receiver
4	STB	Output	Positive going pulse on reception of valid data packet. 10 μ s duration
5	MODE	Input	RX=0V, TX=Vdd (no pull-up, only read at reset/power up)
6	NC	-	-
7	NC	-	-
8	VSS	Supply	Supply Ground
9	OSC2	Output	3.58MHz resonator ¹
10	OSC1	Input	3.58MHz resonator ¹
11 - 18	DA0 - DA7	Output	8 bits of Data A ²
19	VSS	Supply	Supply Ground
20	VDD	Supply	4.5-5.5V supply (decouple with 0.1 μ F close to IC) 2.0V-5.5V (low voltage version)
21 - 24	A0 - A3	Input	Least significant 4 bits of Address (Internal pull-ups to Vdd) ²
25 - 28	DB0 - DB3	Output	Least significant 4 bits of Data B ²

Notes:

- OSC1, 2 require a 3.58MHz ceramic resonator with internal capacitors like Murata CSTLA3M58G55-B0. If a 2 pin resonator or crystal is used, then two 15pF-22pF caps are needed: one from OSC1 to 0V another from OSC2 to 0V. 100 Ω series resistor between OSC2 and crystal may be required when driving low frequency crystal with High Speed (H) CTR124H version.
- Absolute maximum source/sink current from each DA0-DA7, DB0-DB3, A0-A3 pins is 25mA
Absolute maximum total current from DA0-DA7 port and DB0-DB3, A0-A3 port is 200mA
- MODE pin is only read at reset/power up. Connect to either Vdd (Encoder) or 0V (Decoder).
- Without external loads the CTR124 draws <2mA from 5V supply.
- Standard version can be used down to 4V for <20MHz oscillator.
Low voltage version can be used down to 2V for <4MHz oscillator.
- High Speed, CTR124H, version should not be used with Narrow Band FM radio modules.

Encoded Data Packet Format

Transmission format is 1kbps differential Manchester encoding when using 3.58MHz resonator. Oscillator frequency can be decreased to suit narrow band RF module data rate requirements. CTR124H IC running at 20MHz can be used with wideband radio modules for fast data transmission.

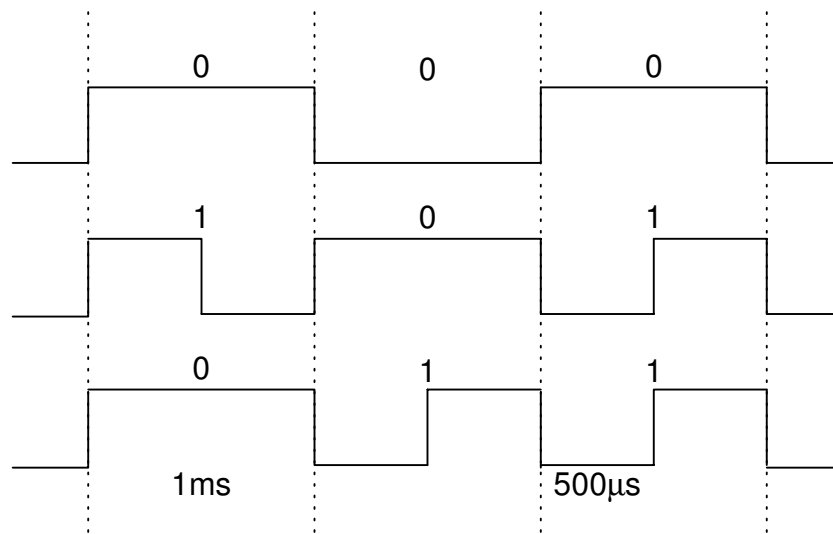

Figure 4: 1kbps differential Manchester coding of '1' and '0'

Control124 transmits a 6-byte burst, with 8 bits of preamble and 4 bits postamble. When firing up the transmitter from cold Control124 puts in an extra 55ms especially for Narrow Band FM transmitter and receiver requiring longer power-up to stable data time.

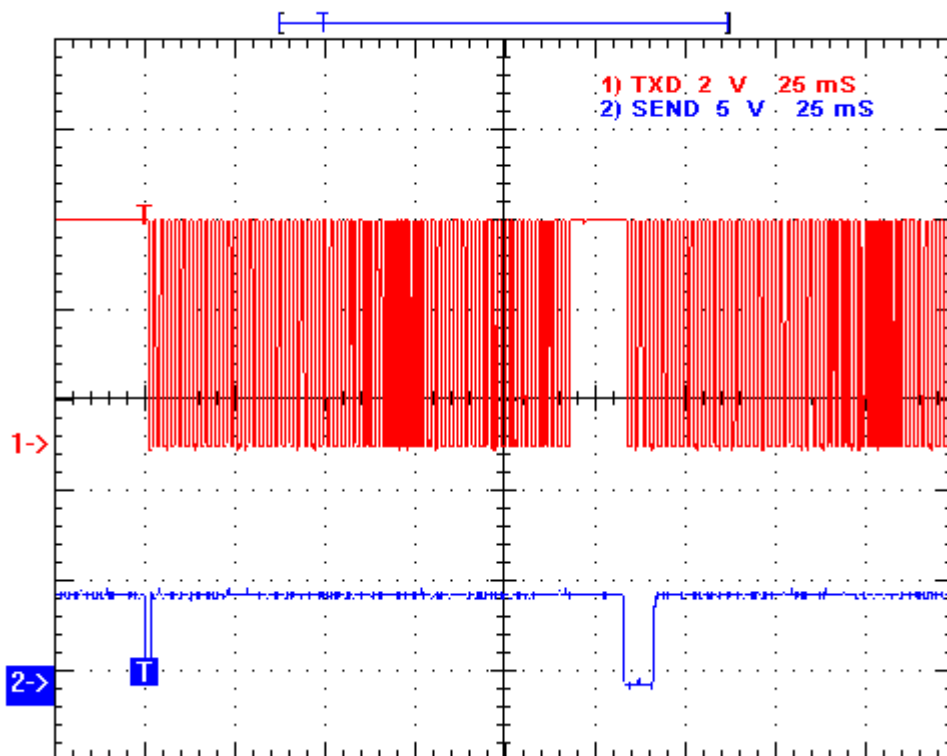

Figure 5: Push button transmission with 55ms power-up preamble

The large amount of sync code, address and checksum reduce the likelihood of false calling on noise to an insignificant degree, while the breaking up of the data sequences with bit7 zeros is to reduce the likelihood of the decoder mistaking particular sequences in the data for sync codes.

Differential Manchester encoding converts the 0000 into 11001100 which is the bit pattern equivalent to preamble required to settle adaptive data slicer in the RF receiver module.

Preamble = 11001100 this byte is not decoded.
 Sync1 = 10111111
 Sync2 = 111100(A7)(B7)
 DataA = 0(DA6-DA0)
 DataB = 0(DB6-DB0)
 Address = 0(A5-A0)0
 Checksum = sum of (DA7-DA0) + (DB7-DB0) + Adr(whole byte) truncated to 8 bits

This allows 6 bits of address and 2 data bytes per 60ms burst when 3.58MHz resonator is used.

	Preamble	Sync1	Sync2	Data A	Data B	Address	Check Sum	Postamble
0000000000000000	11001100	10111111	111100(DA7)(DB7)	0(DA6:DA0)	0(DB6:DB0)	0(A5:A0)0	DA7:DA0+DB7:DB0 +A7:A0	0000

Figure 6: Control124 data packet

In the following example, Control124 in Encoder mode is set with the following.

DA7	DA6	DA5	DA4	DA3	DA2	DA1	DA0	DB3	DB2	DB1	DB0	A3	A2	A1	A0
0	1	1	0	1	0	0	1	1	0	1	0	1	0	0	1

The Control124 will packetise the address and data into the following format.

Preamble	Sync1	Sync2	Data A	Data B	Address	Checksum	Postamble
11001100	10111111	11110010	01101001	00001010	00010010	10000101	0000

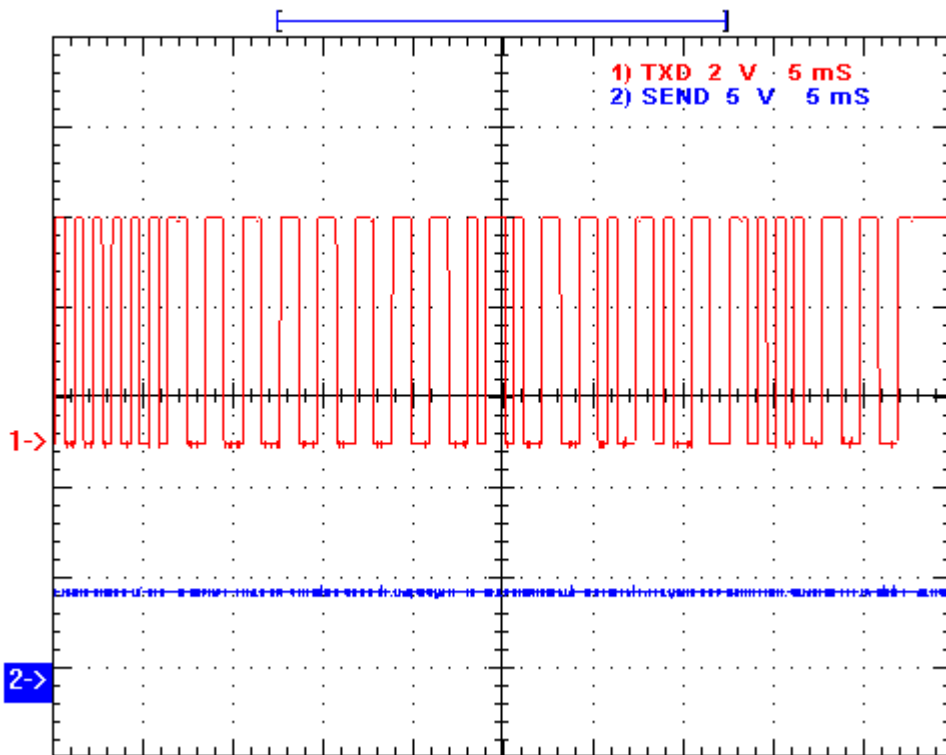

Figure 7: Synchronisation codes, DataA, DataB, Address, Checksum and Postamble

Application Modes

Mode	Setup	Description
4 wires	Latch = 0V (connect) SEND = 0V (connect)	Continuous transmission like wire connection
Pushbutton	Latch = Vdd (connect) SEND = 0V (push button)	Decoder outputs active only when transmitter is keyed
Latched Pushbutton	Latch = 0V (connect) SEND = 0V (push button)	Decoder outputs hold state of last transmission

Ordering Information

CTR124-000-SS	Control124 (≤ 4 MHz)- No Frequency - Shrink Small Outline
CTR124-000-SO	Control 124 (≤ 4 MHz)- No Frequency - Small Outline
CTR124-000-DIL	Control 124 (≤ 4 MHz)- No Frequency - Plastic Dual In Package
CTR124L-000-SS	Control124 Low Voltage (≤ 4 MHz) - No Frequency - SSOP
CTR124L-000-SO	Control124 Low Voltage (≤ 4 MHz) - No Frequency - SO
CTR124L-000-DIL	Control124 Low Voltage (≤ 4 MHz) - No Frequency - PDIP
CTR124H-000-SS	Control124 High Speed (4MHz-20MHz) - No Frequency - SSOP
CTR124H-000-SO	Control124 High Speed (4MHz-20MHz) - No Frequency - SO
CTR124H-000-DIL	Control124 High Speed (4MHz-20MHz) - No Frequency - PDIP

Radiometrix Ltd
Hartcran House
231 Kenton Lane
Harrow, Middlesex
HA3 8RP
ENGLAND
Tel: +44 (0) 20 8909 9595
Fax: +44 (0) 20 8909 2233
sales@radiometrix.com
www.radiometrix.com

Copyright notice

This product data sheet is the original work and copyrighted property of Radiometrix Ltd. Reproduction in whole or in part must give clear acknowledgement to the copyright owner.

Limitation of liability

The information furnished by Radiometrix Ltd is believed to be accurate and reliable. Radiometrix Ltd reserves the right to make changes or improvements in the design, specification or manufacture of its subassembly products without notice. Radiometrix Ltd does not assume any liability arising from the application or use of any product or circuit described herein, nor for any infringements of patents or other rights of third parties which may result from the use of its products. This data sheet neither states nor implies warranty of any kind, including fitness for any particular application. These radio devices may be subject to radio interference and may not function as intended if interference is present. We do NOT recommend their use for life critical applications.

The Intrastat commodity code for all our modules is: 8542 6000

R&TTE Directive

After 7 April 2001 the manufacturer can only place finished product on the market under the provisions of the R&TTE Directive. Equipment within the scope of the R&TTE Directive may demonstrate compliance to the essential requirements specified in Article 3 of the Directive, as appropriate to the particular equipment.

*Further details are available on The Office of Communications (Ofcom) web site:
<http://www.ofcom.org.uk/radiocomms/ifi/>*

*Information Requests
Ofcom
Riverside House
2a Southwark Bridge Road
London SE1 9HA
Tel: +44 (0)20 7981 3000
Fax: +44 (0)20 7981 3333
information.requests@ofcom.org.uk*

*European Radiocommunications Office (ERO)
Peblingehus
Nansensgade 19
DK 1366 Copenhagen
Tel. +45 33896300
Fax +45 33896330
ero@ero.dk
www.ero.dk*