

500mW UHF RF power amplifier

AFS2 amplifier module is intended to increase the transmitted power of a Radiometrix multi channel TR2M transceiver module. It provides transmit and receive paths, and can be simply 'dropped into' the aerial connection. The AFS2 may be usable with other 100mW output devices, but no guarantees can be offered.



Figure 1: AFS2-458

Features

- Conforms to EN 300 220-3 and EN 301 489-3
- Custom variants from 420MHz to 470MHz on any 5MHz band
- TX and RX path with <1dB loss
- 500mW RF power output (for 100mW in)
- Operation at +5V (regulated)
- Low current consumption: 250mA transmit, <2mA receive
- Fully screened
- Small Size: 33 x 23 x 9mm

Applications

- Handheld terminals
- EPOS and inventory tracking
- Data loggers
- Industrial telemetry and telecommand
- In-building environmental monitoring and control
- High-end security and fire alarms

AFS2 : 500mW power amplifier + RF switch

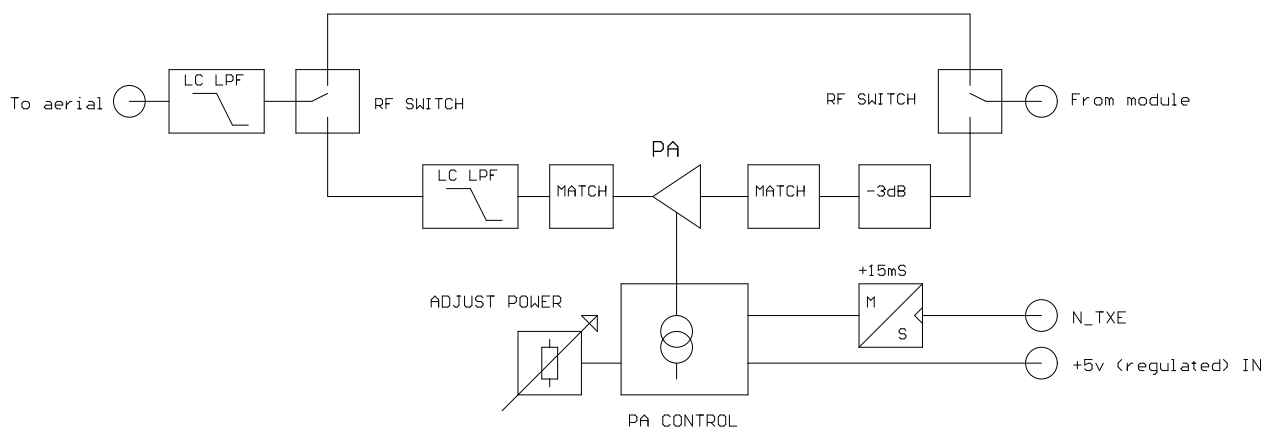

Figure 2: AFS2 block diagram

User interface

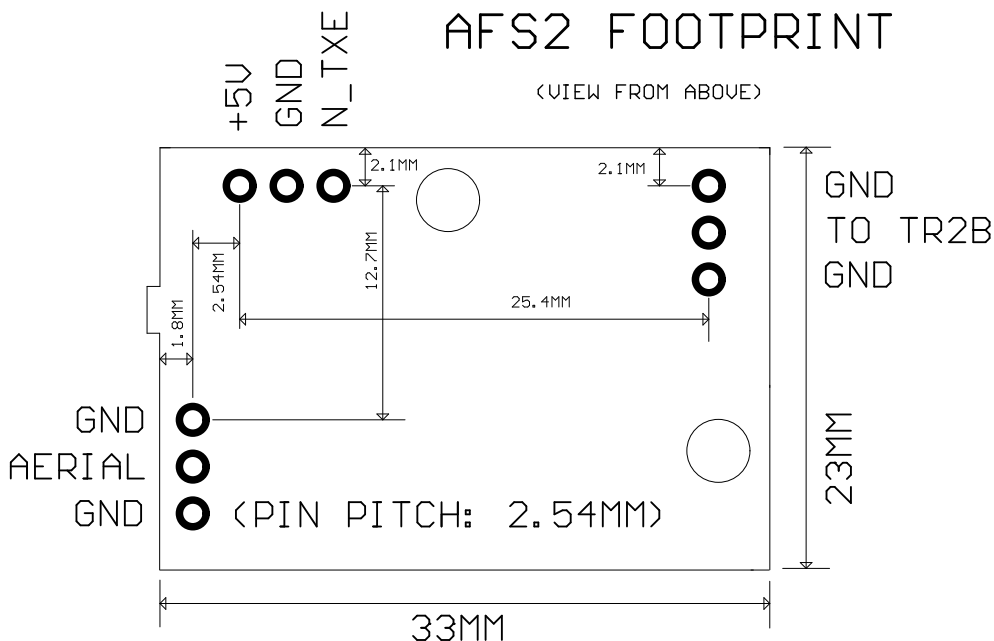

Figure 3: AFS2 pin-out and dimension

Pin description

Pin	Name	Function
RF		
1	RF GND	RF Ground
2	Aerial	RF connection to aerial (50 Ω)
3	RF GND	RF Ground
User		
1	Vcc	Regulated +5v supply, at <250mA
2	0V	Supply Ground
3	$\overline{\text{TXE}}$	Transmit mode enable (active low, 100K pullup to +5v)
RF Module		
1	RF GND	RF Ground
2	RF in/out	RF connection to radio module
3	RF GND	RF Ground

NOTES:

1. This amplifier expects a 100mW power level to be output from the radio on transmit.
2. The TXE line should be tied to the TR2M TXE input. When this line is asserted (low) the amplifier is turned on (drawing 280-300mA) and the RF switching connects it between the module and the aerial. When it is inactive (high or floating) a low loss path is provided for the rx signals, from aerial to the module.
3. If a low power transmit mode is needed, the receive path is bidirectional, and capable of carrying up to 100mW of power. In this case the radio must be set to transmit, but the AFS2 pin $\overline{\text{TXE}}$ must be left in the inactive (high) state.
4. Following the return of $\overline{\text{TXE}}$ to inactive (high), the AFS2 remains in transmit mode for another 15mS, to allow the output of the radio to ramp down, before changing over to receive mode.
5. This unit requires a regulated +5v rail, during transmit, and during receive.
6. This version cannot be used with in i1200 modem mode, unless a separate means of driving the TXE pin is provided. (see relevant application notes)
7. This is a 500mW output product. Good grounding (mount onto a groundplane and tack solder all can walls to this), good quality aerials, properly mounted, and a low impedance power supply are required if full performance is to be reliably obtained. If feasible, we recommend mounting the module, and the board it is on, inside a metal enclosure, with the RF cable taken to a bulkhead connector. All signal and power feeds should be filtered and/or decoupled. Failure to observe these measures can cause modulation distortion ('recirculation' effects) or instability. Also be aware of the effect that the strong RF fields generated by this device (and it's aerial) can have upon other adjacent circuitry if this is not properly screened, filtered or otherwise protected. Regulators, sensitive analogue circuitry, and microprocessors seem especially interference prone.

Condensed specifications

Frequency	458MHz (standard) Any 10MHz wide segment within 420-470MHz band
<i>Transmitter</i>	
<i>Output power</i>	500mW +/- 1dB (250mW by special order)
<i>TX hold time</i>	15mS after TXE goes high
TX spuri	<-40dBm
Receive path loss	<1dB (bi directional)
Supply	<i>voltage</i> +5V regulated
	<i>Current</i> 250mA transmit
	<2mA receive (TXE high or floating)
Operating temperature	-20 to +70 °C (Storage -30 to +70 °C)
Size	33 x 23 x 9 mm
Spurious radiations	Compliant with ETSI EN 300 220-3 and EN 301 489-3
Interface	<i>User</i> 3 pin 0.1" pitch molex
	<i>RF Module</i> 3 pin 0.1" pitch molex
	<i>RF</i> 3 pin 0.1" pitch molex

Variants and ordering information

AFS2 is manufactured in the 458MHz as standard:

AFS2-458

Matching Transceiver:

TR2M-458-5-A (100mW, with TXE wire for modem operation)

TR2M-436.5-10-ARS (435MHz -438MHz Amateur Radio Satellite band Uplink usage)

Matching Transmitters

LMT2-458-10 (100mW)

TX2M-458-5 (100mW)

Other frequency variants can be supplied to individual customer requirements in the Any 10MHz wide segment within 420-470MHz band.

Radiometrix Ltd

**Hartcran House
231 Kenton Lane
Harrow, Middlesex
HA3 8RP
ENGLAND**

**Tel: +44 (0) 20 8909 9595
Fax: +44 (0) 20 8909 2233
sales@radiometrix.com
www.radiometrix.com**

Copyright notice

This product data sheet is the original work and copyrighted property of Radiometrix Ltd. Reproduction in whole or in part must give clear acknowledgement to the copyright owner.

Limitation of liability

The information furnished by Radiometrix Ltd is believed to be accurate and reliable. Radiometrix Ltd reserves the right to make changes or improvements in the design, specification or manufacture of its subassembly products without notice. Radiometrix Ltd does not assume any liability arising from the application or use of any product or circuit described herein, nor for any infringements of patents or other rights of third parties which may result from the use of its products. This data sheet neither states nor implies warranty of any kind, including fitness for any particular application. These radio devices may be subject to radio interference and may not function as intended if interference is present. We do NOT recommend their use for life critical applications.

The Intrastat commodity code for all our modules is: 8542 6000

R&TTE Directive

After 7 April 2001 the manufacturer can only place finished product on the market under the provisions of the R&TTE Directive. Equipment within the scope of the R&TTE Directive may demonstrate compliance to the essential requirements specified in Article 3 of the Directive, as appropriate to the particular equipment. Further details are available on The Office of Communications (Ofcom) web site:

<http://www.ofcom.org.uk/radiocomms/ifi/>

Information Requests

*Ofcom
Riverside House
2a Southwark Bridge Road
London SE1 9HA
Tel: +44 (0)845 456 3000 or 020 7981 3040
Fax: +44 (0)20 7783 4033
information.requests@ofcom.org.uk*

European Radiocommunications Office (ERO)

*Peblingehus
Nansensgade 19
DK 1366 Copenhagen
Tel. +45 33896300
Fax +45 33896330
ero@ero.dk
www.ero.dk*