

WRX2

PRELIMINARY

Issue A, 11 November 2009

433.92MHz Low Cost FM Receiver

The WRX2 is a low cost wide band FM receiver in a Radiometrix SIL standard pin out and footprint. It offers an economical and reliable low power data link without compromising the receiver performance. WRX2 receiver and the matching TX2A transmitter enable the simple implementation of a wireless data link at up to 12 kbps at distances up to 75 metres in-building and 300 metres open ground.



Figure 1: WRX2-433-12

Features

- Conforms to ETSI EN 300 220-3 (radio) and EN 301 489-3 (EMC)
- Standard frequencies: 433.92MHz
- Custom frequencies available in 433MHz (EU) band
- Data rates up to 12kbps
- Usable range over 300m

Technical Summary

- Double conversion FM superhet
- SAW band pass filter, image rejection: 45dB
- Supply range: +3V or 2.9V - 15V (regulator version) @ 22mA
- Data bit rate: 12kbps max.
- Receiver sensitivity: -115dBm (for 12dB SINAD)
- Local Oscillator (LO) re-radiation: <-65dBm
- Adjacent Channel: -65dBm
- Blocking: -75dB
- Size: 47 x 17 x 6 mm (47 x 17 x 8.5mm with can)

Applications

- Handheld terminals
- EPOS and inventory tracking
- Sensor nodes
- Data loggers
- Industrial telemetry and telecommand
- In-building environmental monitoring and control
- High-end security and fire alarms

Evaluation platforms: Universal Evaluation Kit, NBEK + SIL carrier

WRX2 receiver

WRX2

Single channel receiver

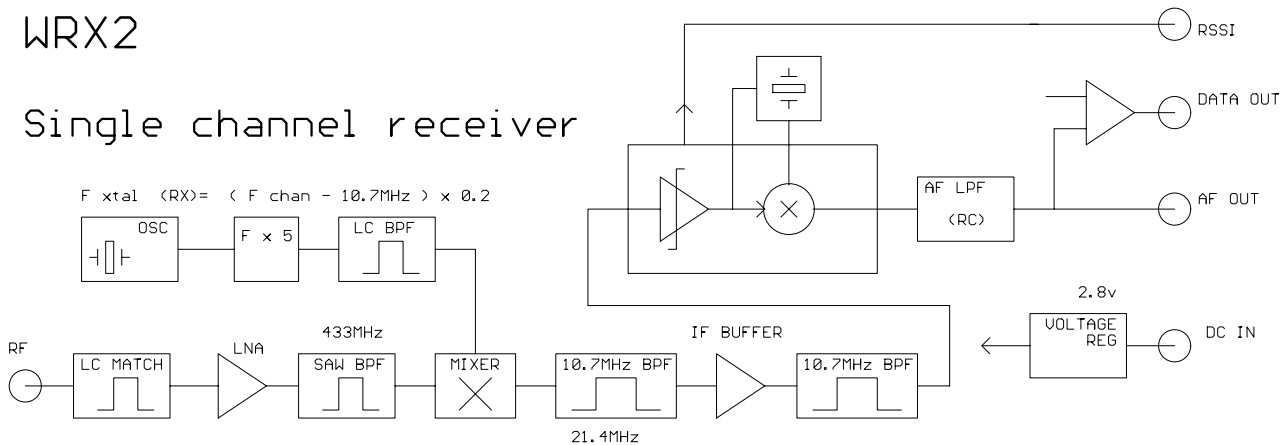

Figure 2: WRX2 block diagram

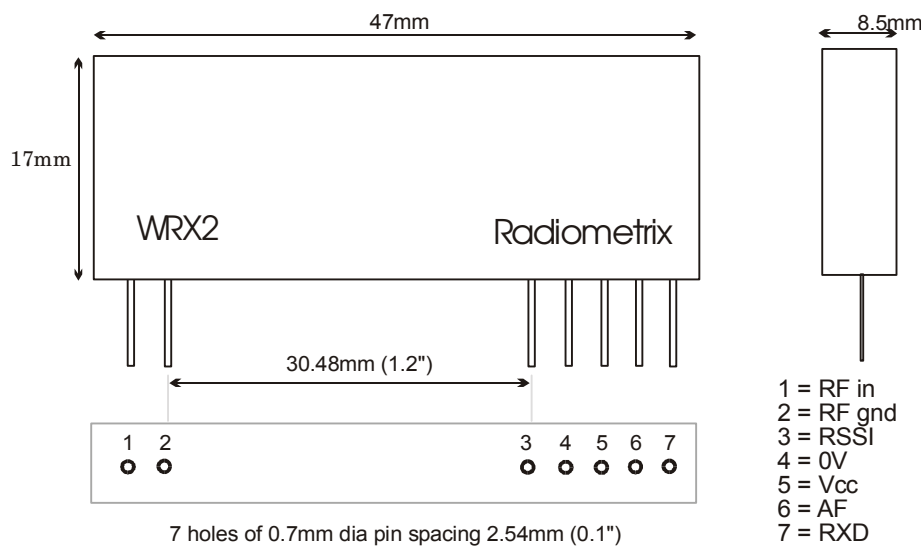

Figure 3: WRX2 pin-out and dimension (with can)

User interface

WRX2 pin	Name	Function
1	RF in	50Ω RF input from the antenna
2	RF gnd	RF Ground is internally connected to the module screen and pin 4 (0V). These pins should be directly connected to the RF return path - e.g. coax braid, main PCB ground plane etc.
3	RSSI	Received Signal Strength Indicator with >60dB range. DC level between 0.3V and 1.5V
4	0V	Ground
5	Vcc	2.9 – 15V DC power supply ²
6	AF	600mV _{pk-pk} audio. DC coupled, approx 1.4V bias
7	RXD	Received Data output from the internal data slicer. The data is squared version of the Audio signal on pin 6 and is true data, i.e. as fed to the transmitter. Output is "open-collector" format with internal 10kΩ pull-up to Vcc (pin 5). Suitable for bi-phase codes

Notes:

1. Pin out is as RX2A receiver
2. The unit can be offered in regulated (2.9 to 15v) or the cheaper +3v only (no regulator fitted) versions
3. The standard version has no can, and mounts vertically on Batten and Allen leadframe pins. A second version is for horizontal mounting with square header pins and an NRX2 case fitted
4. Standard version is 6mm thick. The horizontal (canned) unit is 8.5mm

Absolute maximum ratings

Exceeding the values given below may cause permanent damage to the module.

Operating temperature	-20°C to +55°C
Storage temperature	-30°C to +80°C
Vcc, RXD (pins 5, 7)	-0.3V to +16.0V
RSSI, AF (pins 3, 6)	-0.3V to +Vcc V
RF in (pin 1)	±50V @ <10MHz, +13dBm @ >10MHz

Performance specifications

(Vcc = 3V / temperature = 20°C unless stated)

	pin	min.	typ.	max.	units	notes
DC supply						
Supply voltage	4, 5	2.9	3.0	15	V	
Supply current	4, 5	-	22	-	mA	
RF/IF						
RF centre frequency	1, 6	-	433.92	-	MHz	1
Frequency stability		-	±10	-	KHz	
Channel spacing		-	350	-	KHz	
Number of channels		-	1	-		
RF sensitivity @ 12dB SINAD	1, 6	-	-115	-	dBm	2
RSSI range	1, 3	-	60	-	dB	3
Blocking	1	-	75	-	dB	
Image rejection	1	-	50	-	dB	
Adjacent channel rejection	1	-	70	-	dB	
Spurious response rejection	1	-	55	-	dB	
LO re-radiation	1	-	-	-65	dBm	4
Baseband						
Baseband bandwidth @ -3dB	6	0	-	6	kHz	5
AF level	6	-	600	700	mV _{p-p}	6
DC offset on AF out	6	-	1.4	-	V	
Distortion on recovered AF	6	-	2	5	%	
Dynamic timing						
<i>Power up with signal present</i>						
Power up to valid RSSI	5, 4	-	3	-	ms	
Power up to valid AF	5, 6	-	2	-	ms	
Power up to stable data	5, 7	-	TBA	10	ms	
<i>Signal applied with supply on</i>						
Signal to valid RSSI	1, 4	-	2	-	ms	
Signal to valid AF	1, 6	-	1	-	ms	
Signal to stable data	1, 7	-	TBA	5	ms	7
Time between data transitions	7	0.1	-	TBA	ms	

Notes:

- 433.92MHz is standard, other UHF 431-437MHz by special order
- for 12 dB SINAD / 1KHz @ 30KHz deviation
- See applications information for further details
- Exceeds EN/EMC requirements at all frequencies.
- 3dB bandwidth @ 12kbps NRZ data rate
- For received signal with ±30kHz FM deviation. AF output is inverted with respect to TXD input.
- For 50:50 mark to space ratio (i.e. squarewave).

Applications information

Power supply requirements

WRX2 modules have built-in regulator which deliver a constant 2.8V to the module circuitry when the external supply voltage is 2.9V or greater, with 40dB or more of supply ripple rejection. This ensures constant performance up to the maximum permitted rail, and removes the need for external supply decoupling except in cases where the supply rail is extremely poor (ripple/noise content $>100\text{mV}_{\text{pk-pk}}$).

WRX2 Received Signal Strength Indicator (RSSI)

The WRX2 receiver incorporates a wide range RSSI which measures the strength of an incoming signal over a range of 60dB. This allows assessment of link quality and available margin and is useful when performing range tests.

The output on pin 3 of the module has a standing DC bias of 0.3V with no signal, rising to around 1.5V at maximum indication (saturation point @ -60dBm).

Typical RSSI characteristic is as shown below:

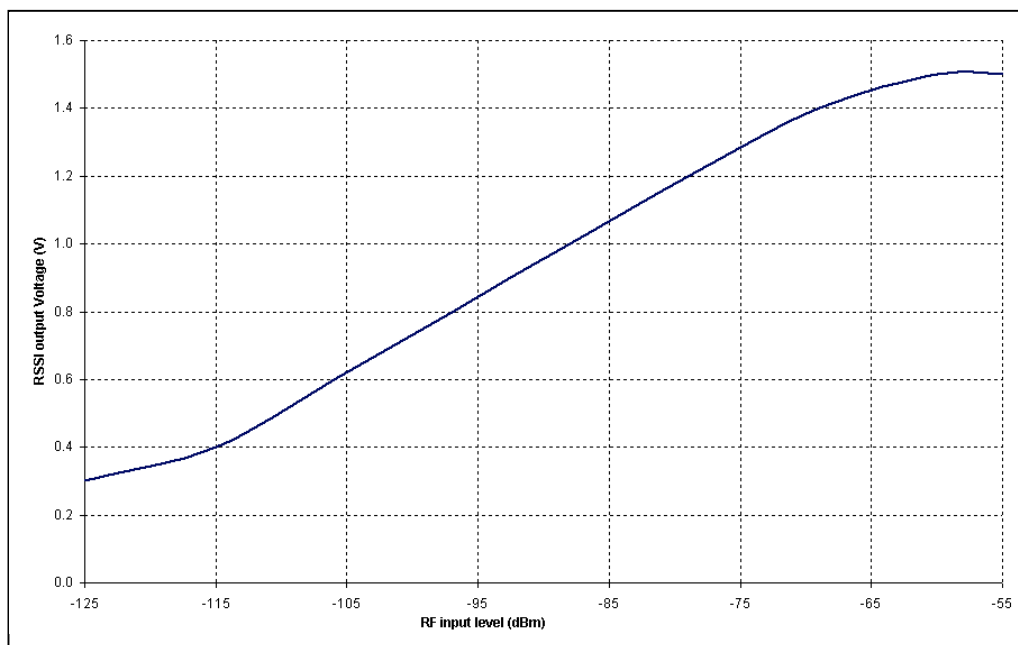

Figure 4: RSSI response curve

Please note that the actual RSSI voltage at any given RF input level varies somewhat between units. The RSSI facility is intended as a relative indicator only - it is not designed to be, or suitable as, an accurate and repeatable measure of absolute signal level or transmitter-receiver distance.

Antennas

The choice and positioning of transmitter and receiver antennas is of the utmost importance and is the single most significant factor in determining system range. The following notes are intended to assist the user in choosing the most effective antenna type for any given application.

Integral antennas

These are relatively inefficient compared to the larger externally-mounted types and hence tend to be effective only over limited ranges. They do however result in physically compact equipment and for this reason are often preferred for portable applications. Particular care is required with this type of antenna to achieve optimum results and the following should be taken into account:

1. Nearby conducting objects such as a PCB or battery can cause detuning or screening of the antenna which severely reduces efficiency. Ideally the antenna should stick out from the top of the product and be entirely in the clear, however this is often not desirable for practical/ergonomic reasons and a compromise may need to be reached. If an internal antenna must be used try to keep it away from other metal components and pay particular attention to the “hot” end (i.e. the far end) as this is generally the most susceptible to detuning. The space around the antenna is as important as the antenna itself.
2. Microprocessors and microcontrollers tend to radiate significant amounts of radio frequency hash which can cause desensitisation of the receiver if its antenna is in close proximity. The problem becomes worse as logic speeds increase, because fast logic edges generate harmonics across the UHF range which are then radiated effectively by the PCB tracking. In extreme cases system range may be reduced by a factor of 5 or more. To minimise any adverse effects situate antenna and module as far as possible from any such circuitry and keep PCB track lengths to the minimum possible. A ground plane can be highly effective in cutting radiated interference and its use is strongly recommended.

A simple test for interference is to monitor the receiver RSSI output voltage, which should be the same regardless of whether the microcontroller or other logic circuitry is running or in reset.

The following types of integral antenna are in common use:

Quarter-wave whip. This consists simply of a piece of wire or rod connected to the module at one end. At 434MHz the total length should be 164mm from module pin to antenna tip including any interconnecting wire or tracking. Because of the length of this antenna it is almost always external to the product casing.

Helical. This is a more compact but slightly less effective antenna formed from a coil of wire. It is very efficient for its size, but because of its high Q it suffers badly from detuning caused by proximity to nearby conductive objects and needs to be carefully trimmed for best performance in a given situation. The size shown is about the maximum commonly used at 434MHz and appropriate scaling of length, diameter and number of turns can make individual designs much smaller.

Loop. A loop of PCB track having an inside area as large as possible (minimum about 4cm²), tuned and matched with 2 capacitors. Loops are relatively inefficient but have good immunity to proximity detuning, so may be preferred in shorter range applications where high component packing density is necessary.

Integral antenna summary:

	whip	helical	loop
Ultimate performance	***	**	*
Ease of design set-up	***	**	*
Size	*	***	**
Immunity to proximity effects	**	*	***

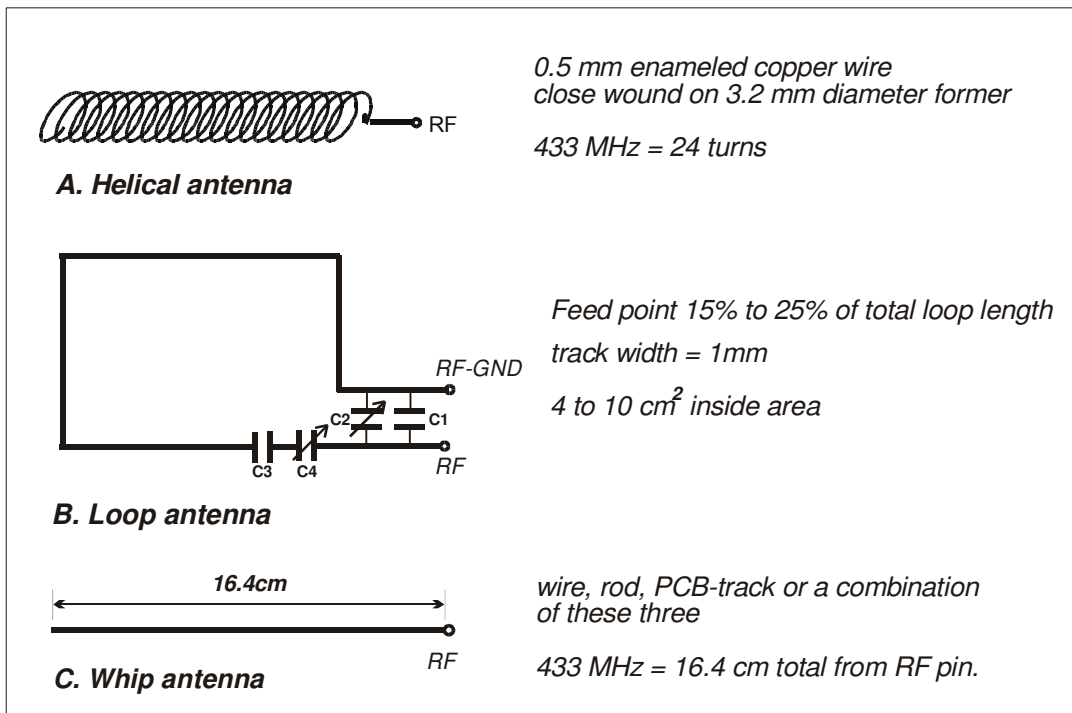

Figure 5: integral antenna configurations

External antennas

These have several advantages if portability is not an issue, and are essential for long range links. External antennas can be optimised for individual circumstances and may be mounted in relatively good RF locations away from sources of interference, being connected to the equipment by coax feeder.

Helical. Of similar dimensions and performance to the integral type mentioned above, commercially-available helical antennas normally have the coil element protected by a plastic moulding or sleeve and incorporate a coax connector at one end (usually a straight or right-angle BNC/SMA type). These are compact and simple to use as they come pre-tuned for a given application, but are relatively inefficient and are best suited to shorter ranges.

Quarter-wave whip. Again similar to the integral type, the element usually consists of a stainless steel rod or a wire contained within a semi-flexible moulded plastic jacket. Various mounting options are available, from a simple BNC/SMA connector to wall brackets, through-panel fixings and magnetic mounts for temporary attachment to steel surfaces.

A significant improvement in performance is obtainable if the whip is used in conjunction with a metal ground plane. For best results this should extend all round the base of the whip out to a radius of the length of the whip used (under these conditions performance approaches that of a half-wave dipole) but even relatively small metal areas will produce a worthwhile improvement over the whip alone. The ground plane should be electrically connected to the coax outer at the base of the whip. Magnetic mounts are slightly different in that they rely on capacitance between the mount and the metal surface to achieve the same result.

A ground plane can also be simulated by using 3 or 4 quarter-wave radials equally spaced around the base of the whip, connected at their inner ends to the outer of the coax feed. A better match to a 50Ω coax feed can be achieved if the elements are angled downwards at approximately 30-40° to the horizontal.

Module mounting considerations

The module may be mounted vertically or bent horizontal to the motherboard. Good RF layout practice should be observed – in particular, any ground return required by the antenna or feed should be connected directly to the RF GND pin at the antenna end of the module, and not to the OV pin which is intended as a DC ground only. All connecting tracks should be kept as short as possible to avoid any problems with stray RF pickup.

If the connection between module and antenna does not form part of the antenna itself, it should be made using 50Ω microstrip line or coax or a combination of both. It is desirable (but not essential) to fill all unused PCB area around the module with ground plane.

The module may be potted if required in a viscous compound which cannot enter the screen can.

Warning: DO NOT wash the module. It is not hermetically sealed.

Variants and ordering information

WRX2 receiver is manufactured in the 433.92MHz as standard:

WRX2-433-12

Matching Transmitters

TX2A-433-64 (10mW)

TX2H-433-64 (25mW)

TX2S-433-40-3V (1mw)

TX2S-433-40-3V-10mW

Evaluation platforms: Universal Evaluation Kit, NBEK + SIL carrier

Other frequency variants can be supplied to individual customer requirements in the 433MHz (European) band

Radiometrix Ltd

Hartcran House
231 Kenton Lane
Harrow, Middlesex
HA3 8RP
ENGLAND
Tel: +44 (0) 20 8909 9595
Fax: +44 (0) 20 8909 2233
sales@radiometrix.com
www.radiometrix.com

Copyright notice

This product data sheet is the original work and copyrighted property of Radiometrix Ltd. Reproduction in whole or in part must give clear acknowledgement to the copyright owner.

Limitation of liability

The information furnished by Radiometrix Ltd is believed to be accurate and reliable. Radiometrix Ltd reserves the right to make changes or improvements in the design, specification or manufacture of its subassembly products without notice. Radiometrix Ltd does not assume any liability arising from the application or use of any product or circuit described herein, nor for any infringements of patents or other rights of third parties which may result from the use of its products. This data sheet neither states nor implies warranty of any kind, including fitness for any particular application. These radio devices may be subject to radio interference and may not function as intended if interference is present. We do NOT recommend their use for life critical applications.

The Intrastat commodity code for all our modules is: 8542 6000

R&TTE Directive

After 7 April 2001 the manufacturer can only place finished product on the market under the provisions of the R&TTE Directive. Equipment within the scope of the R&TTE Directive may demonstrate compliance to the essential requirements specified in Article 3 of the Directive, as appropriate to the particular equipment. Further details are available on The Office of Communications (Ofcom) web site:

<http://www.ofcom.org.uk/radiocomms/ifi/>

Information Requests

*Ofcom
Riverside House
2a Southwark Bridge Road
London SE1 9HA
Tel: +44 (0)845 456 3000 or 020 7981 3040
Fax: +44 (0)20 7783 4033
information.requests@ofcom.org.uk*

European Radiocommunications Office (ERO)

*Peblingehus
Nansensgade 19
DK 1366 Copenhagen
Tel. +45 33896300
Fax +45 33896330
ero@ero.dk
www.ero.dk*
