

## 869MHz Narrow Band FM Transmitter

**The SAT3 transmitter modules offer a 10mW RF output UHF data link in Radiometrix SIL standard pin-out and footprint. This makes the SAT3 ideally suited to low power applications using narrow band transmitters. Together with the matching SAR3 receiver a one-way radio data link can be achieved over a distance up to 1km+ with suitable choice of data rate and antennas.**

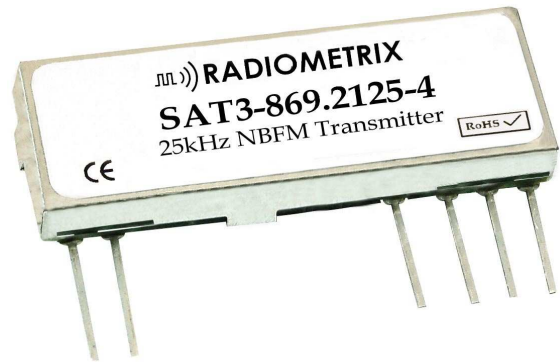

Figure 1: SAT3 transmitter

### Features

- Conforms to EN 300 220-3 and EN 301 489-3
- Standard frequency 869.2125MHz
- 25 kHz channel spacing
- Data rates up to 4kbps
- Usable range over 1km+
- Fully screened
- Low power requirements

The SAT3 is a narrow band radio transmitter module for use in long range data transfer applications at ranges up to 1kilometre+

### Applications

- Automatic meter reading (AMR)
- Car and building security
- Social alarms
- Industrial telemetry and telecommand
- In-building environmental monitoring and control
- EPOS and inventory tracking

### Technical Summary

- Size: 32 x 13.5 x 4.5mm
- Operating frequency: 869.2125MHz
- Supply range: 5v
- Current consumption: 45mA Max
- Data bit rate: 4kbps max.
- Transmit power: 10dBm (10mW) nominal

**Evaluation platforms:** Universal Evaluation Kit, NBEK + SIL carrier

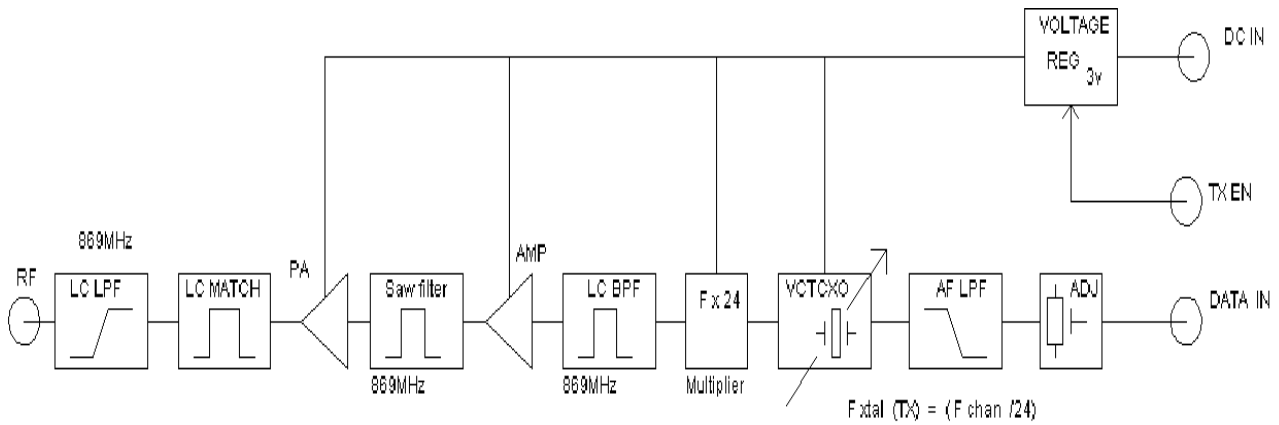

Figure 2: SAT3 Block diagram

## Functional description

The SAT3 transmitter consists of a frequency modulated Voltage Controlled Temperature Controlled Crystal Oscillator (VCTCXO) feeding a frequency multiplier with two stage amplifier and RF filter. Operation can be controlled by the EN (Enable) line, the transmitter achieving full RF output typically within 1.5ms of this line being pulled high. The RF output is filtered to ensure compliance with the appropriate radio regulations and fed to the 50Ω antenna pin.

## User interface

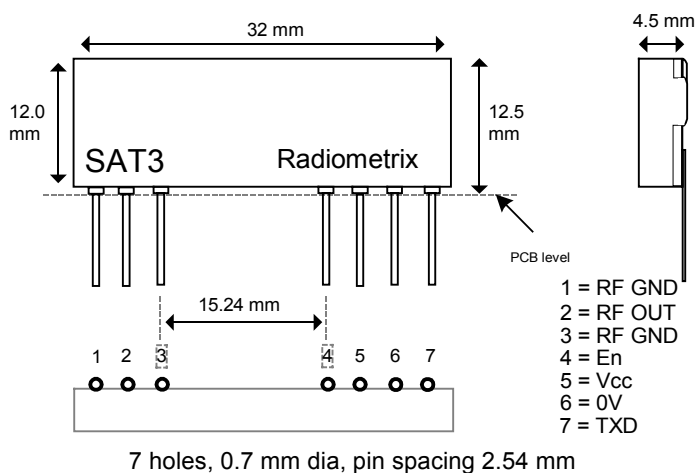

Figure 3: SAT3 pin-out and dimension

ENT1L pin	Name	Function
1, 3	RFgnd	RF Ground
2	RF out	50Ω RF input from the antenna
4	EN	Pull high to enable Transmitter (Note 1)
5	VCC	5V DC power supply
6	0V	Ground
7	TXD	DC coupled input for 5V CMOS logic. $R_{in} = 200k\Omega$

### NOTES:

1. EN pin should not be left floating

## Absolute maximum ratings

Exceeding the values given below may cause permanent damage to the module.

Operating temperature	-20°C to +60°C
Storage temperature	-30°C to +70°C
RF in (pin 1)	±50V @ <10MHz, +13dBm @ >10MHz
VCC (pin 5)	-0.3V to +16V
EN (pin 4)	-0.3V to +16V
All other pins	-0.3V to +5.5V

## Performance specifications

(Vcc = 5V / temperature = 25°C unless stated)

General	pin	min.	typ.	max.	units	notes
<b>DC supply</b>						
Supply voltage	5	3.1	5	16	V	
TX Supply current @ 10mW	5		38	45	mA	
Antenna pin impedance	2		50		Ω	
RF centre frequency			869.2125		MHz	
Channel spacing			25		kHz	
Number of channels			1			
<b>RF</b>						
RF power output	2	+9	+10	+11	dBm	1
Spurious emissions	2				dBm	5
Adjacent channel TX power			> -40		dBm	
Frequency accuracy		-2.5	0	+2.5	kHz	2
FM deviation (peak)		±2.5	±3	±3.5	kHz	3
<b>Baseband</b>						
Modulation bandwidth @ -3dB		0	3	4.0	kHz	
TXD input level (logic low)	7		0		V	4
TXD input level (logic high)	7		5		V	4
<b>Dynamic timing</b>						
TX select to full RF			1.5	2	ms	

### Notes:

1. Measured into 50Ω resistive load.
2. Total over full supply and temperature range.
3. With 0V – 5.0V modulation input.
4. To achieve specified FM deviation.
5. Meets EN300-220

## Applications information

### Power supply requirements

The SAT3 has a built-in regulator which delivers a constant 3V to the transmitter frequency control and RF circuitry when the external supply voltage is 3.1V or greater. This ensures constant frequency stability and removes the need for external supply decoupling except in cases where the supply rail is extremely poor (ripple/noise content  $>0.1V_{p-p}$ ).

### TX modulation requirements

The module is factory-set to produce the specified FM deviation with a TXD input to pin 14 of 5V amplitude, i.e. 0V “low”, 5V “high” (other variants available on request)

If the data input level is greater than 5V, a resistor must be added in series with the TXD input to limit the modulating input voltage to a maximum of 5V on pin 7. TXD input resistance is 200k $\Omega$  to ground.

### Expected range

Predicting the range obtainable in any given situation is notoriously difficult since there are many factors involved. The main ones to consider are as follows:

- Type and location of antennas in use
- Type of terrain and degree of obstruction of the link path
- Sources of interference affecting the receiver
- “Dead” spots caused by signal reflections from nearby conductive objects
- Data rate and degree of filtering employed

The following are typical examples – but range tests should always be performed before assuming that a particular range can be achieved in a given situation:

Data rate	Tx antenna	Rx antenna	Environment	Range
1.2kbps	half-wave	half-wave	rural/open	1000m +

**Note:** The figure for 1.2kbps assumes that the receiver bandwidth has been suitably reduced by utilising an outboard sellen-key active audio filter and data slicer or similar arrangement.

The SAT3’s TXD input is normally driven directly by logic levels but will also accept analogue drive (e.g. 2-tone signalling). In this case it is recommended that TXD (pin 14) be DC-biased to 2.5V approx. with the modulation ac-coupled and limited to a maximum of  $5V_{p-p}$  to minimise distortion over the link.

Although the modulation bandwidth of the SAT3 extends down to DC it is not advisable to use data containing a DC component. This is because frequency errors and drifts between the transmitter and receiver occur in normal operation, resulting in DC offset errors on the receiver’s audio output.

### Module mounting considerations

The modules may be mounted vertically or bent horizontal to the motherboard.

Good RF layout practice should be observed. If the connection between module and antenna is more than about 20mm long use 50 $\Omega$  microstrip line or coax or a combination of both. It is desirable (but not essential) to fill all unused PCB area around the module with ground plane.

### Variants and ordering information

The SAT3 transmitter is manufactured in the following variant as standard:

SAT3-869.2125-3 (869.2125MHz)

#### Matching Receiver:

SAR3-869-8

**Radiometrix Ltd**  
**Hartcran House**  
**231 Kenton Lane**  
**Harrow, Middlesex**  
**HA3 8RP**  
**ENGLAND**  
**Tel: +44 (0) 20 8909 9595**  
**Fax: +44 (0) 20 8909 2233**

[sales@radiometrix.com](mailto:sales@radiometrix.com)  
[www.radiometrix.com](http://www.radiometrix.com)

### Copyright notice

This product data sheet is the original work and copyrighted property of Radiometrix Ltd. Reproduction in whole or in part must give clear acknowledgement to the copyright owner.

### Limitation of liability

The information furnished by Radiometrix Ltd is believed to be accurate and reliable. Radiometrix Ltd reserves the right to make changes or improvements in the design, specification or manufacture of its subassembly products without notice. Radiometrix Ltd does not assume any liability arising from the application or use of any product or circuit described herein, nor for any infringements of patents or other rights of third parties which may result from the use of its products. This data sheet neither states nor implies warranty of any kind, including fitness for any particular application. These radio devices may be subject to radio interference and may not function as intended if interference is present. We do NOT recommend their use for life critical applications.

The Intrastat commodity code for all our modules is: 8542 6000.

### R&TTE Directive

After 7 April 2001 the manufacturer can only place finished product on the market under the provisions of the R&TTE Directive. Equipment within the scope of the R&TTE Directive may demonstrate compliance to the essential requirements specified in Article 3 of the Directive, as appropriate to the particular equipment.

Further details are available on The Office of Communications (Ofcom) web site:

<http://www.ofcom.org.uk/radiocomms/ifi/>

*Information Requests*  
*Ofcom*  
*Riverside House*  
*2a Southwark Bridge Road*  
*London SE1 9HA*  
*Tel: +44 (0)845 456 3000 or 020 7981 3040*  
*Fax: +44 (0)20 7783 4033*  
*information.requests@ofcom.org.uk*

*European Radiocommunications Office (ERO)*  
*Peblingehus*  
*Nansensgade 19*  
*DK 1366 Copenhagen*  
*Tel. +45 33896300*  
*Fax +45 33896330*  
*ero@ero.dk*  
*www.ero.dk*