

## LMT3

Issue 1, 22 January 2013

### NBFM Multi-channel transmitter for 868MHz SRD band

The LMT3 is a 25kHz channel narrowband multichannel transmitter offering up to 25mW RF power. LMT3 can be paired with the Category 1 compliant receiver intended for European 869.2-869.25MHz Social Alarm application. It can also be used for any 868 - 870MHz band Non-Specific SRD applications. The module offers a low power, reliable data link in an industry-standard pin out and footprint.



We're sorry,  
this image is  
temporarily  
unavailable.

Figure 1: LMT3 transmitter

#### Features

- Conforms to EN 300 220-3 and EN 301 489-3
- PLL synthesizer with TCXO
- Data rates up to 5 kbps for standard module
- Usable range over 500m @ 25mW
- Fully screened, Low profile
- Low power requirements

#### Applications

- Social Alarm
- Handheld terminals
- EPOS equipment, barcode scanners
- Data loggers
- Industrial telemetry and telecommand
- In-building environmental monitoring and control
- High-end security and fire alarms
- DGPS systems
- Vehicle data up/download
- Heavy vehicle/machinery controls

#### Technical Summary

- Social Alarm frequencies: CH0: 869.2125MHz, CH1: 869.2375MHz
- Custom frequency within 865MHz - 870MHz
- 32 channels
- Transmit power: +10dBm (10mW) / +14dBm (25mW)
- Supply range: 3.1 – 15V (TX @ 10mW), 4.1 – 15V (TX @ 25mW)
- Current consumption: 34mA @ 10mW, 68mA @ 25mW
- Data bit rate: 5kbps max. (standard module)
- Serial configuration by inverted RS232 at 3V CMOS level

**Evaluation platforms:** NBEK + LM Series carrier

**Matching receiver:** COR3-869-5

# LMT3 868MHz band NBFM transmitter

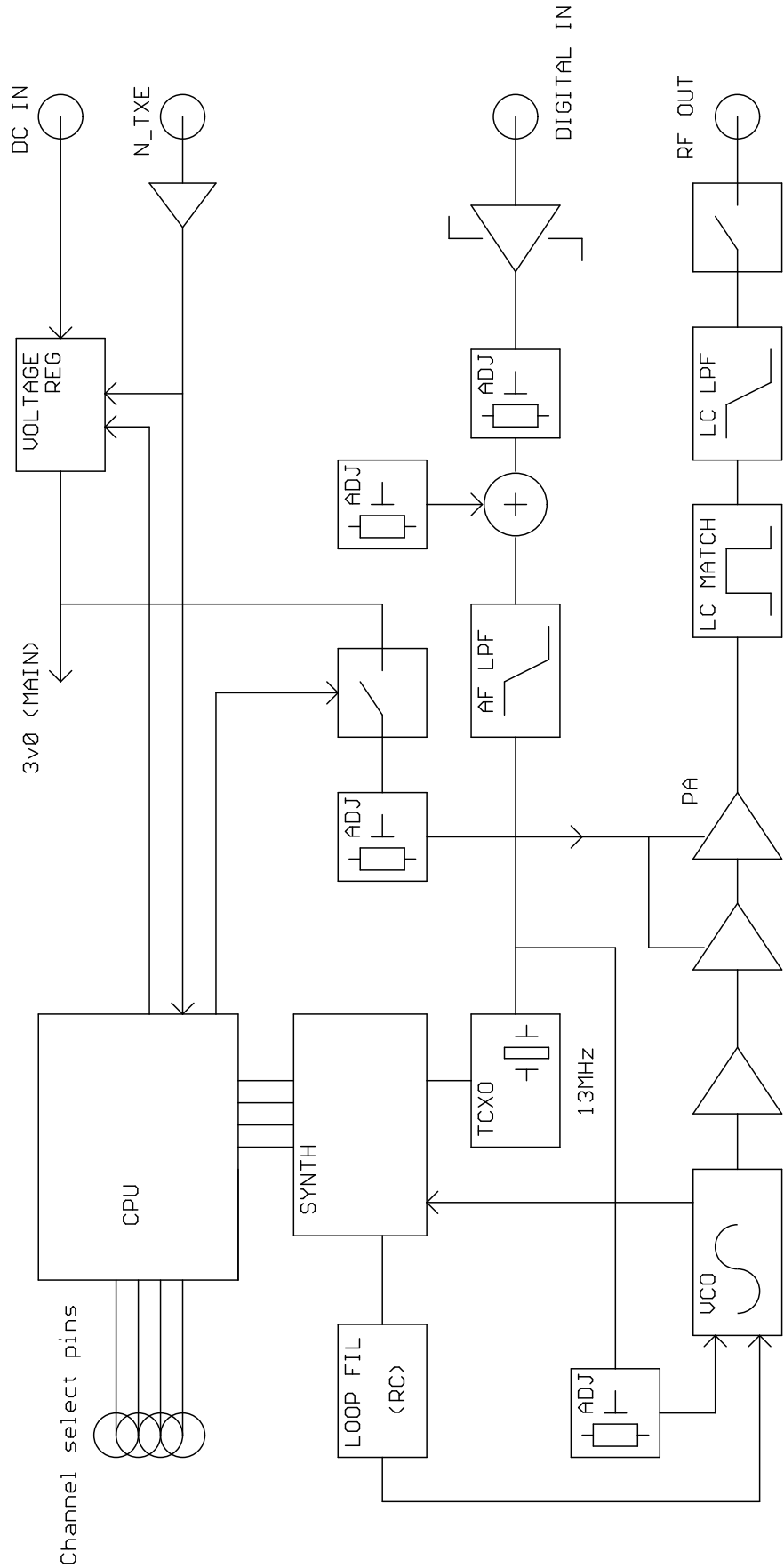

Figure 2: LMT3 block diagram

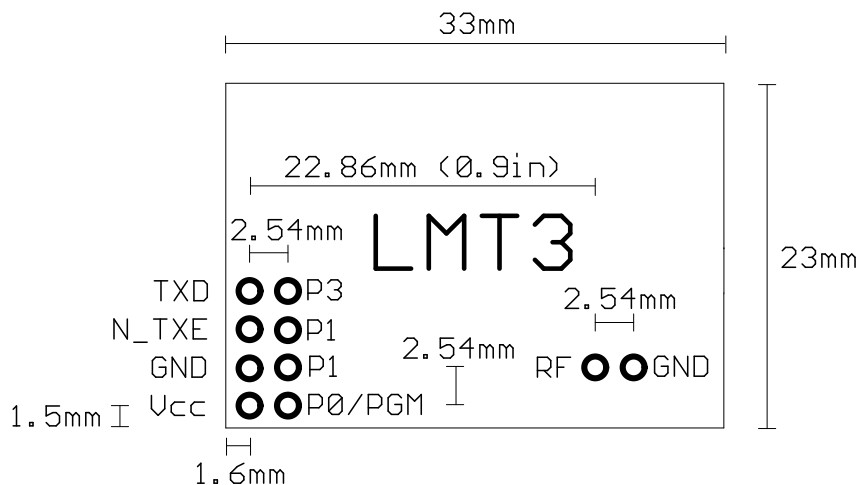

Figure 3: LMT3 footprint (top view)

### Pin description – LMT3

Pin	Name	Function
1a	Vcc	3.1 – 15V power supply (@ 10mW) 4.1 – 15V power supply (@ 25mW)
2a	0V	Ground
3a	TXE	Transmit Enable (active low)
4a	TXD	DC coupled input for 3V CMOS logic. $R_{in}=47k\Omega$
5a	No pin	Not present in LMT3
1b	P0/PGM	Parallel Channel select LSB Serial frequency programming / configuration <sup>1</sup>
2b	P1	Parallel Channel select
3b	P2	Parallel Channel select
4b	P3	Parallel Channel select MSB
5b	No pin	Not present in LMT3

#### Notes:

1. Serial programming is by an inverted, CMOS logic level, 2400 baud RS232 datastream applied to the P0 pin.
2. Channel select inputs have pullups (50k $\Omega$ ) to 3v internal rail. Do not exceed 3V logic levels on this port.
3. Channel select inputs are active low
4. TXE has a 100k $\Omega$  pullup to Vcc
5. All pins are on an 0.1" grid
6. The pins 5a/b are not present, but are included in footprint for compatibility with other units in this family
7. In the 'off' state a PIN switch open circuits the RF output pin. There are no 'off' state spuri.
8. 10mW unit will operate (with marginally reduced specifications and lower (6-8mW) output power) from a 3.0V rail. This must be well regulated and without noise or ripple, as in this state the unit's internal regulator no longer operates, and provides no supply rejection.

## Serial interface commands

2400 baud RS232. 8 bit data, no parity, 1 start bit, 1 or 2 stop bits.

Serial data is sent to the unit on one of the parallel channel select pins (P0). It is very important that the unit does not 'decode' switch bounce in ordinary operation as a command string, or spurious re-writing of the e2prom will result. For this reason the user must send the 16 character string ENABLESERIALMODE (followed by a carriage return) to activate the serial command mode before sending any of the command strings listed below. Command mode is disabled on power down, or on reception of a # character. To successfully program the unit, it must be enabled (TXE low).

GOCHAN aa	Serially select channel aa, where aa is ch0 to ch31
LOAD aa nnnnn	Set value of N register for channel aa, where aa is Channels 0 to 31
SETPAR	Channel selected by 4 bit parallel inputs (ch0 to ch15 only)
SETSER	Channel selected by most recent GOCHAN operation
RVALUE rrrr	Set value for R register
SINGLE nnnnn	Set value of N for single channel operation. N value NOT stored in EEPROM
<cr>	Process entry
/	Clear all buffers
#	Disable command mode

aa = a two digit channel number from 00 to 31

nnnnn = synthesizer N register value (up to 65535)

rrrr = synthesizer R register value (up to 16383)

$$N_{TX} = \frac{f_{RF}}{f_{Channelspacing}} = \frac{869.200MHz}{25kHz} = 34768 \quad R = \frac{f_{TCXO}}{f_{channelspacing}} = \frac{13MHz}{25kHz}, \text{ So } R=520$$

**Note:** A pause of at least 50ms must be allowed between command strings (EEPROM programming time).

SINGLE mode does not store the N value in EEPROM. Therefore the unit is inoperative after a power down until either another valid SINGLE command is received, or mode is changed by a GOCHAN, SETPAR or SETSER command. SINGLE mode is intended for frequency agile applications.

If an N value greater than 65535 is needed then an offset of +65536 can be selected by setting bit 15 of the R value high (the N value is then reduced by 65536 of course)"

Example:  $F_{out} = 869.2125$

$F_{comp} = 12.5KHz$

$N = 69537$  This exceeds 65535, so:

Bit 15 of R is set : RVALUE 33808

65536 is subtracted: LOAD00 4001

## Condensed specifications

<b>Frequency</b>	Social Alarm (SAL) variant: CH0: 869.2125MHz, CH1: 869.2375MHz User customisable frequencies: 865MHz – 870MHz
<i>Frequency stability</i>	±1.5kHz
<i>Channel spacing</i>	25kHz
<i>Number of channels</i>	16 channels controlled by parallel port or 32 via RS232 interface
Operating temperature	-10 °C to +60 °C (Storage -30 °C to +70 °C)
Spurious radiations	Compliant with ETSI EN 300 220-3 and EN 301 489-3
<b>Transmitter</b>	
Output power	+10dBm (10mW) ±1dB +14dBm (25mW) ±1dB
Peak deviation	±3kHz
TX on switching time	30ms from TXE transition
Modulation type	FSK (F3D)
TX modulation bandwidth	DC – 5kHz (3V CMOS compatible)
Adjacent channel TX power	<-37dBm
TX spurious	<-45dBm (no RF output in Standby)
<b>Supply</b>	
Voltage	3.1V – 15V (10mW) 4.1 – 15V (25mW)
Current	34mA @ 10mW (nominal) 68mA @ 25mW (nominal) <5µA standby (TXE high or floating)
Inputs	data (CMOS/TTL compatible)
Size	33 x 23 x 9mm
Interface	<i>User</i> 10 (8) pin 0.1" pitch dual row (5+5) header
	<i>RF</i> 2pin 0.1" pitch
Recommended PCB hole size	1.2mm

## Ordering Information:

Part No.	Frequency (MHz)	RF power (mW)	Channel spacing (kHz)	Data rate (kbps)
LMT3-869.2125-5	869.2125	10	25	5
LMT3-869-5-SAL	869.200 - 869.250	10	25	5
LMT3-869-5	868 - 870	10	25	5
LMT3-869-5-25mW	868 - 870	25	25	5

## Matching COR3 receiver

Part Number	Frequency	Module mounting	Pins
COR3-869.2125-5-H	869.2125MHz	Horizontal Mounting, Perpendicular pins	RF, RFGND, RSSI, GND, VCC, AF, RXD
COR3-869-5-SAL	869.2-869.25MHz	Vertical Mounting, Parallel pins	RF, RFGND, RSSI, GND, VCC, AF, RXD P0/PGM
COR3-869-5-SAL-H	869.2-869.25MHz	Horizontal Mounting, Perpendicular pins	RF, RFGND, RSSI, GND, VCC, AF, RXD P0/PGM
COR3-869-5	868-870MHz	Vertical Mounting, Parallel pins	RF, RFGND, RSSI, GND, VCC, AF, RXD P3, P2, P1, P0/PGM

# CEPT/ERC Rec 70-03, 868 MHz Band Plan

<b>Applications</b>	Non-specific SRD	Alarm	Non-specific SRD	Social Alarm	Alarm	Non-specific SRD	Alarm	Non-specific SRD
<b>Channel Spacing</b>	No Spacing	25kHz or WB	No Spacing	25kHz	25kHz	25kHz or Wide Band	25kHz	No Spacing
<b>Duty Cycle</b>	<1% or LBT	<1%	<0.1% or LBT	<0.1%	<1%	<10% or LBT	<10%	up to 100%

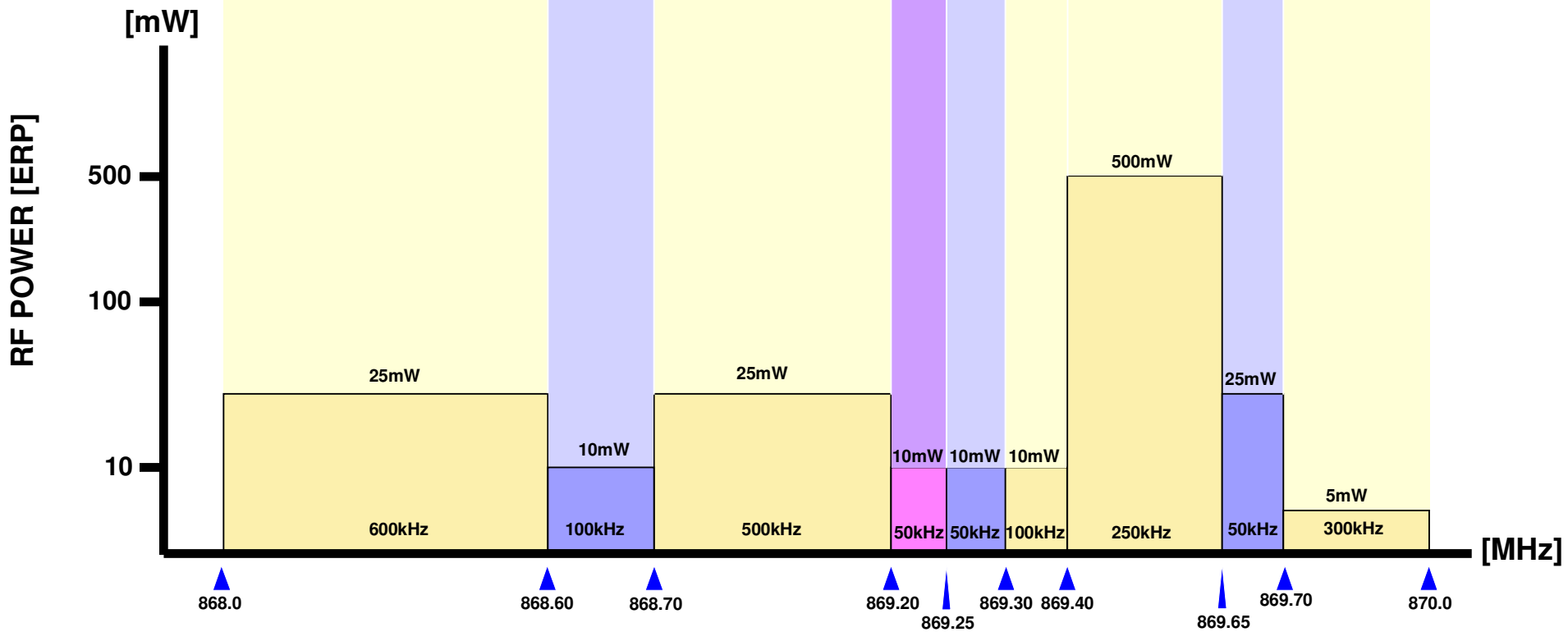

**Radiometrix Ltd**  
**Hartcran House**  
**231 Kenton Lane**  
**Harrow, Middlesex**  
**HA3 8RP**  
**ENGLAND**  
**Tel: +44 (0) 20 8909 9595**  
**Fax: +44 (0) 20 8909 2233**  
**sales@radiometrix.com**  
**www.radiometrix.com**

**Copyright notice**

This product data sheet is the original work and copyrighted property of Radiometrix Ltd. Reproduction in whole or in part must give clear acknowledgement to the copyright owner.

**Limitation of liability**

The information furnished by Radiometrix Ltd is believed to be accurate and reliable. Radiometrix Ltd reserves the right to make changes or improvements in the design, specification or manufacture of its subassembly products without notice. Radiometrix Ltd does not assume any liability arising from the application or use of any product or circuit described herein, nor for any infringements of patents or other rights of third parties which may result from the use of its products. This data sheet neither states nor implies warranty of any kind, including fitness for any particular application. These radio devices may be subject to radio interference and may not function as intended if interference is present. We do NOT recommend their use for life critical applications.

The Intrastat commodity code for all our modules is: 8542 6000.

**R&TTE Directive**

After 7 April 2001 the manufacturer can only place finished product on the market under the provisions of the R&TTE Directive. Equipment within the scope of the R&TTE Directive may demonstrate compliance to the essential requirements specified in Article 3 of the Directive, as appropriate to the particular equipment.

Further details are available on The Office of Communications (Ofcom) web site:

**<http://www.ofcom.org.uk/radiocomms/ifi/>**

*Information Requests*

*Ofcom*

*Riverside House*

*2a Southwark Bridge Road*

*London SE1 9HA*

*Tel: +44 (0)845 456 3000 or 020 7981 3040*

*Fax: +44 (0)20 7783 4033*

*information.requests@ofcom.org.uk*

*European Radiocommunications Office (ERO)*

*Peblingehus*

*Nansensgade 19*

*DK 1366 Copenhagen*

*Tel. +45 33896300*

*Fax +45 33896330*

*ero@ero.dk*

*www.ero.dk*

---