

NEW

Radiometrix

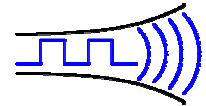

ENX1

Issue 1, 02 March 2009

Hartcran House, 231 Kenton Lane, Harrow, HA3 8RP, England

Tel: +44 (0) 20 8909 9595, Fax: +44 (0) 20 8909 2233

VHF 12.5kHz channel NBFM TRANSCEIVER

The ENX1 transceiver module offers a 100mW RF output VHF data link in a DIL pin-out and footprint. This makes the ENX1 ideally suited to those low power applications where existing narrow band and wideband transmitters provide insufficient range. A half duplex radio data link can be achieved over a distance up to 10km+ with suitable choice of data rate and antennas.



Figure 1: ENX1-169.44375-3

Features

- Standard frequency 169.40625MHz and 169.44375MHz
- Other frequencies from 120MHz to 180MHz
- 12.5 kHz channel spacing
- Data rates up to 3kbps
- Usable range over 10km
- Fully screened
- Low power requirements

The ENX1 is a narrow band radio transceiver module for use in long range data transfer applications at ranges up to 10kilometres.

Applications

- EPOS equipment, barcode scanners
- Data loggers
- Industrial telemetry and telecommand
- In-building environmental monitoring and control
- High-end security and fire alarms
- DGPS systems
- Vehicle data up/download
- Automatic meter reading (AMR)

Technical Summary

- Size: 49 x 34 x 8.7mm
- Operating frequency (standard): 169.40625MHz
- Supply range: 5v
- Current consumption: 75mA TX
- Current consumption: 12mA RX
- Data bit rate: 3kbps max.
- Transmit power: 20dBm (100mW) nominal
- Double conversion FM superhet
- SAW front end filter gives >80dB image rejection
- -115dBm sensitivity @ 1ppm BER
- RSSI output with 50dB range

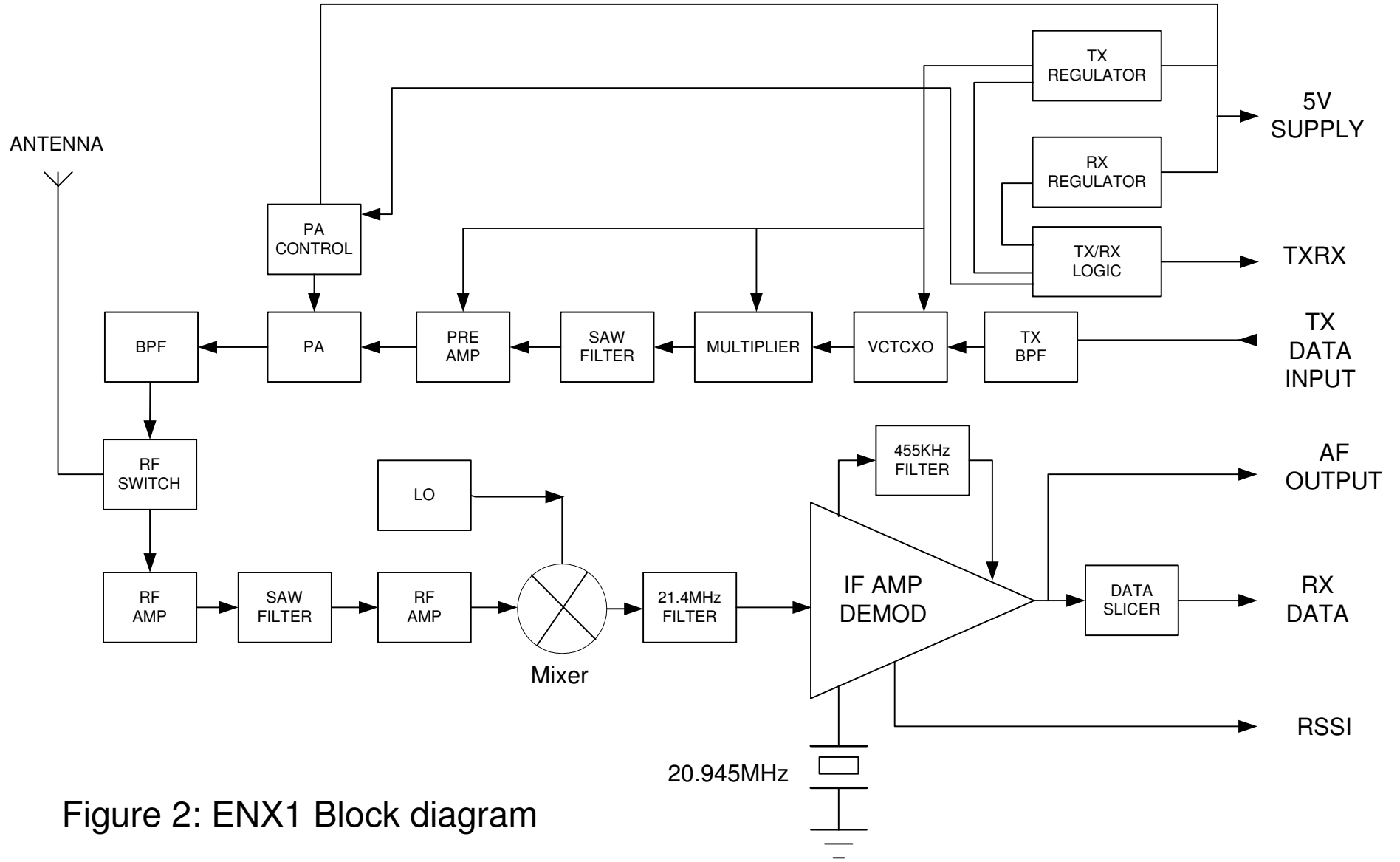

Figure 2: ENX1 Block diagram

Functional description

The ENX1 transceiver consists of a frequency modulated Voltage Controlled Temperature Controlled Crystal Oscillator (VCTCXO) feeding a frequency multiplier with two stage amplifier and RF filter. Final Power Amplifier stage is factory pre-set to appropriate band power level. Operation can be controlled by the TXRX (Enable) line, the transmitter achieving full RF output typically within 7ms of this line being pulled LOW. The RF output is filtered to ensure compliance with the appropriate radio regulations and fed to the 50Ω antenna pin. The receiver uses a saw filter to give high rejection of unwanted signals. Double conversion and narrow filtering ensures that signals in adjacent channels are also rejected.

User Interface

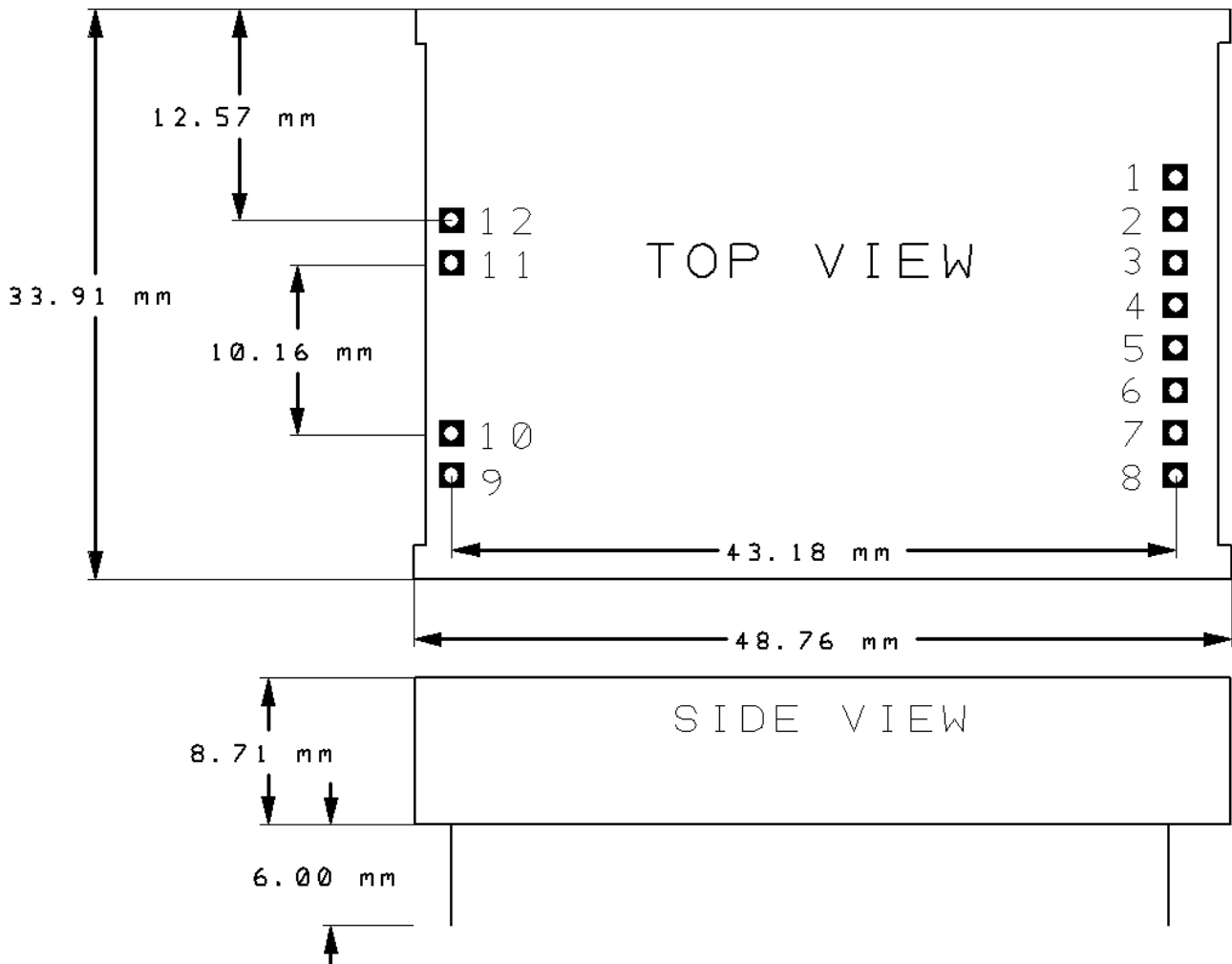

Figure 3: ENX1 pin-out and dimension

ENX1 pin	Name	Function
1	Vcc	5v Supply
2	TXRX	Low = TX, High = RX (Note 1)
3	TXD	DC coupled input for 5V CMOS logic. $R_{in} = 100k\Omega$
4	0V	Ground
5	RSSI	RSSI
6	0V	Ground
7	AF	Receiver AF output
8	RXD	RX data output
9	0V	Ground
10	0V	Ground
11	RF in/out	Antenna connection
12	RF GND	RF Ground

NOTES:

1. TXRX pin should not be left floating

Absolute maximum ratings

Exceeding the values given below may cause permanent damage to the module.

Operating temperature	-20°C to +60°C
Storage temperature	-30°C to +70°C
RF in (pin 11)	±50V @ <10MHz, +13dBm @ >10MHz
All other pins	-0.3V to +5.5V

Performance specifications Transmitter:

(V_{cc} = 5V / temperature = 20°C unless stated)

General	pin	min.	typ.	max.	units	notes
DC supply						
Supply voltage	1	4.5	5	5.5	V	
TX Supply current @ 100mW			75mA		mA	
Antenna pin impedance	12		50		Ω	
RF centre frequency (100mW)			169.40625		MHz	
Channel spacing			12.5		kHz	
Number of channels			1			
RF						
RF power output	12	+19	+20	+21	dBm	1
Spurious emissions					dBm	5
Adjacent channel TX power			-40		dBm	
Frequency accuracy		-1.5	0	+1.5	kHz	2
FM deviation (peak)		±1.4	±1.5	±1.6	kHz	3
Baseband						
Modulation bandwidth @ -3dB		0	2		kHz	
TXD input level (logic low)	3		0		V	4
TXD input level (logic high)	3		5		V	4
Dynamic timing						
TX select to full RF	2		7		ms	

Notes:

1. Measured into 50Ω resistive load.
2. Total over full supply and temperature range.
3. With 0V – 5.0V modulation input.
4. To achieve specified FM deviation.
5. Meets EN300-220

Performance specifications Receiver:*(V_{cc} = 5V / temperature = 20 °C unless stated)*

	pin	min.	typ.	max.	units	notes
DC supply						
Supply voltage	1	4.5	5.0	5.5	V	
Supply current	1	10	12	15	mA	
RF/ IF						
RF sensitivity for 12dB (S+N/N)	12	-118	-120	-	dBm	1,2
RF sensitivity for 1ppm BER	12	-	-115	-	dBm	1,2
RSSI range	5	-	50	-	dB	
IF bandwidth	-	-	7.5	-	kHz	
Image rejection		70	89	-	dB	
LO leakage, conducted		-54	-65	-	dBm	
Adjacent channel rejection			<-70		dB	
Blocking			>80		dB	
Baseband						
Baseband bandwidth @ -3dB	7	0	-	3	kHz	
AF level	7	300	400	450	mV _{P-P}	1
DC offset on AF out	7	0.5	0.75	1.25	V	
Distortion on recovered AF	7	-	3	5	%	1,2
Load capacitance, AFout/RXD	7	-	-	100	pF	
DYNAMIC TIMING						
Power up with signal present						
Power up to valid RSSI	5	-	6.5	7.5	ms	
Power up to stable data	8	-	10	13	ms	
Signal applied with supply on						
RSSI response time (rise/fall)	5	-	100	-	us	
Signal to stable data	8	-	3.5	-	ms	

Notes:

1. For received signal with ± 1.5 kHz FM deviation.
2. Typical figures are for signal at centre frequency

Received Signal Strength Indicator (RSSI)

The module incorporates a wide range RSSI which measures the strength of an incoming signal over a range of approximately 50dB. This allows assessment of link quality and available margin and is useful when performing range tests.

The output on pin of the module has a standing DC bias in the region of 0.6V with no signal, rising to around 1.75V at maximum indication. The RSSI output source impedance is high (~100k Ω) and external loading should therefore be kept to a minimum.

Typical RSSI characteristic is as shown below:

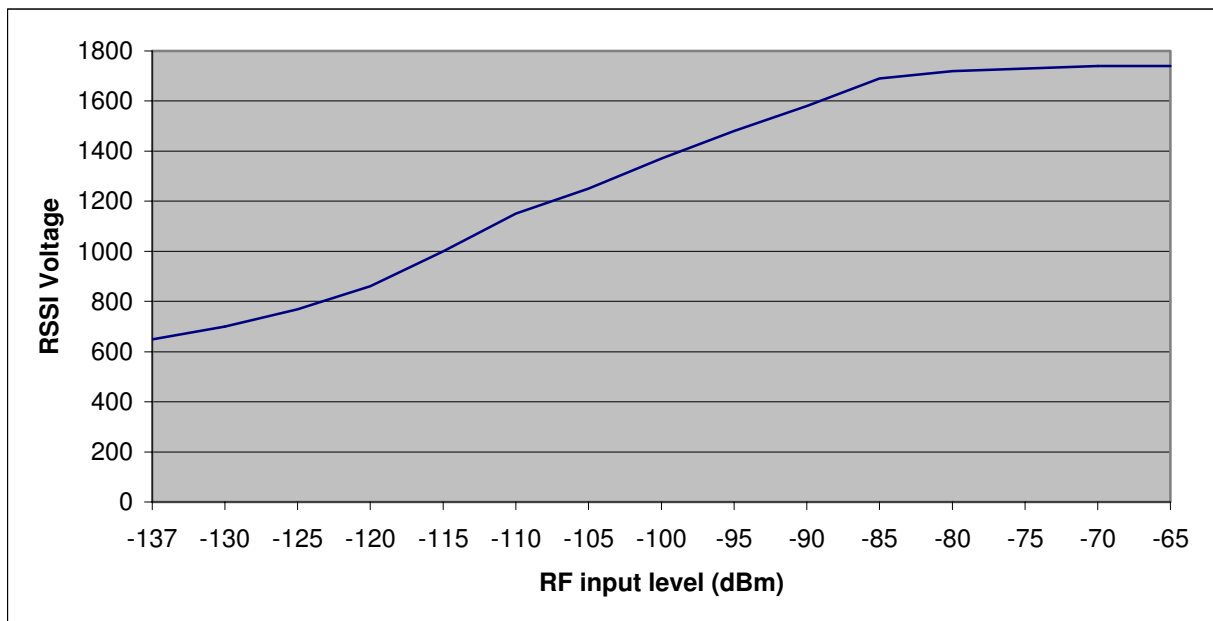

Figure 4: RSSI level with respect to received RF level at ENX1 antenna pin

Applications information

TX modulation requirements

The module is factory-set to produce the specified FM deviation with a TXD input of 5V amplitude, i.e. 0V “low”, 5V “high”

If the data input level is greater than 5V, a resistor must be added in series with the TXD input to limit the modulating input voltage to a maximum of 5V. TXD input resistance is 100k Ω to ground.

Expected range

Predicting the range obtainable in any given situation is notoriously difficult since there are many factors involved. The main ones to consider are as follows:

- Type and location of antennas in use
- Type of terrain and degree of obstruction of the link path
- Sources of interference affecting the receiver
- “Dead” spots caused by signal reflections from nearby conductive objects
- Data rate and degree of filtering employed

The ENX1's TXD input is normally driven directly by logic levels but will also accept analogue drive (e.g. 2-tone signalling). In this case it is recommended that TXD be DC-biased to 2.5V approx. with the modulation ac-coupled and limited to a maximum of 5V_{P-P} to minimise distortion over the link.

Although the modulation bandwidth of the ENX1 extends down to DC it is not advisable to use data containing a DC component. This is because frequency errors and drifts between the transmitter and receiver occur in normal operation, resulting in DC offset errors on the receiver's audio output.

Antennas

The choice and positioning of transmitter and receiver antennas is of the utmost importance and is the single most significant factor in determining system range. The following notes are intended to assist the user in choosing the most effective antenna type for any given application.

Integral antennas

These are relatively inefficient compared to the larger externally-mounted types and hence tend to be effective only over limited ranges. They do however result in physically compact equipment and for this reason are often preferred for portable applications. Particular care is required with this type of antenna to achieve optimum results and the following should be taken into account:

1. Nearby conducting objects such as a PCB or battery can cause detuning or screening of the antenna which severely reduces efficiency. Ideally the antenna should stick out from the top of the product and be entirely in the clear, however this is often not desirable for practical/ergonomic reasons and a compromise may need to be reached. If an internal antenna must be used try to keep it away from other metal components and pay particular attention to the “hot” end (i.e. the far end) as this is generally the most susceptible to detuning. The space around the antenna is as important as the antenna itself.
2. Microprocessors and microcontrollers tend to radiate significant amounts of radio frequency hash which can cause desensitisation of the receiver if its antenna is in close proximity. The problem becomes worse as logic speeds increase, because fast logic edges generate harmonics across the VHF range which are then radiated effectively by the PCB tracking. In extreme cases system range may be reduced by a factor of 5 or more. To minimise any adverse effects situate antenna and module as far as possible from any such circuitry and keep PCB track lengths to the minimum possible. A ground plane can be highly effective in cutting radiated interference and its use is strongly recommended.

The following types of integral antenna are in common use:

Quarter-wave whip. This consists simply of a piece of wire or rod connected to the module at one end. At 169MHz the total length should be 421mm from module pin to antenna tip including any interconnecting wire or tracking. Because of the length of this antenna it is almost always external to the product casing.

Helical. This is a more compact but slightly less effective antenna formed from a coil of wire. It is very efficient for its size, but because of its high Q it suffers badly from detuning caused by proximity to nearby conductive objects and needs to be carefully trimmed for best performance in a given situation. The size shown is about the maximum commonly used at 169MHz and appropriate scaling of length, diameter and number of turns can make individual designs much smaller.

Loop. A loop of PCB track having an inside area as large as possible (minimum about 5cm²), tuned and matched with 2 capacitors. Loops are relatively inefficient but have good immunity to proximity detuning, so may be preferred in shorter range applications where high component packing density is necessary.

Integral antenna summary:

	whip	helical	loop
Ultimate performance	***	**	*
Ease of design set-up	***	**	*
Size	*	***	**
Immunity to proximity effects	**	*	***

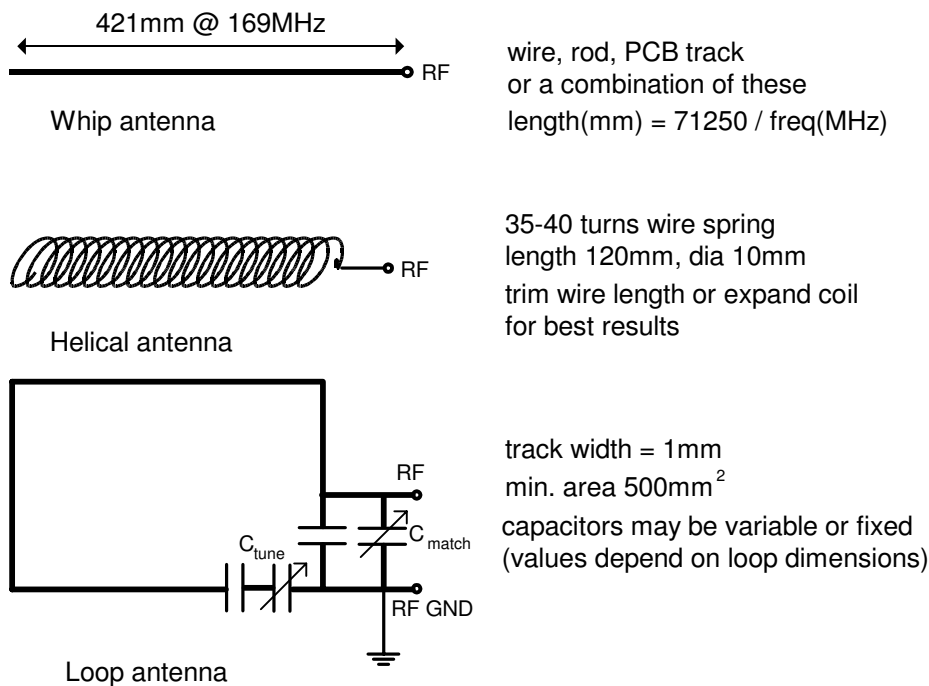

Figure 5: integral antenna configurations

External antennas

These have several advantages if portability is not an issue, and are essential for long range links. External antennas can be optimised for individual circumstances and may be mounted in relatively good RF locations away from sources of interference, being connected to the equipment by coax feeder.

Helical. Of similar dimensions and performance to the integral type mentioned above, commercially-available helical antennas normally have the coil element protected by a plastic moulding or sleeve and incorporate a coax connector at one end (usually a straight or right-angle BNC type). These are compact and simple to use as they come pre-tuned for a given application, but are relatively inefficient and are best suited to shorter ranges.

Quarter-wave whip. Again similar to the integral type, the element usually consists of a stainless steel rod or a wire contained within a semi-flexible moulded plastic jacket. Various mounting options are available, from a simple BNC connector to wall brackets, through-panel fixings and magnetic mounts for temporary attachment to steel surfaces.

A significant improvement in performance is obtainable if the whip is used in conjunction with a metal ground plane. For best results this should extend all round the base of the whip out to a radius of 300mm or more (under these conditions performance approaches that of a half-wave dipole) but even relatively small metal areas will produce a worthwhile improvement over the whip alone. The ground plane should be electrically connected to the coax outer at the base of the whip. Magnetic mounts are slightly different in that they rely on capacitance between the mount and the metal surface to achieve the same result.

A ground plane can also be simulated by using 3 or 4 quarter-wave radials equally spaced around the base of the whip, connected at their inner ends to the outer of the coax feed. A better match to a 50Ω coax feed can be achieved if the elements are angled downwards at approximately 30-40° to the horizontal.

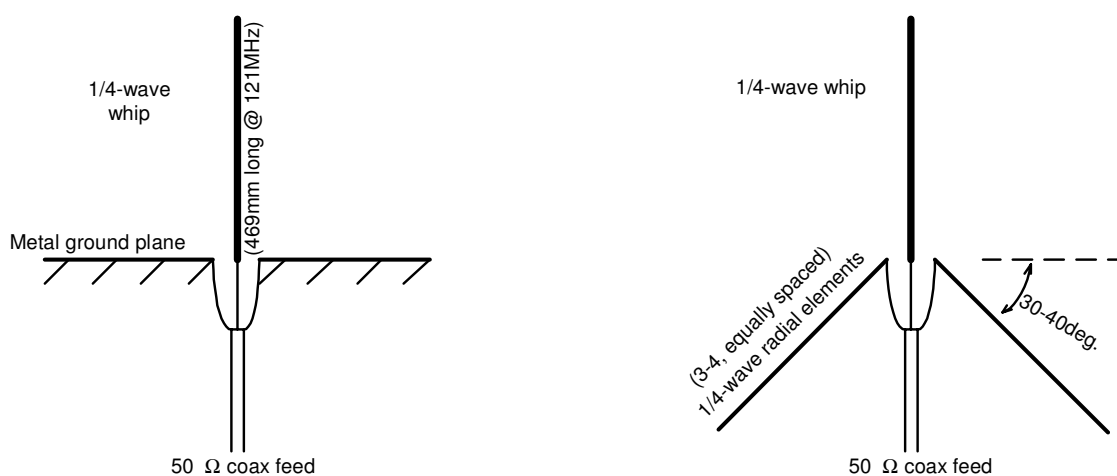

Fig.6: Quarter wave antenna / ground plane configurations

Half-wave. There are two main variants of this antenna, both of which are very effective and are recommended where long range and all-round coverage are required:

1. The half-wave dipole consists of two quarter-wave whips mounted in line vertically and fed in the centre with coaxial cable. The bottom whip takes the place of the ground plane described previously. A variant is available using a helical instead of a whip for the lower element, giving similar performance with reduced overall length. This antenna is suitable for mounting on walls etc. but for best results should be kept well clear of surrounding conductive objects and structures (ideally >1m separation).
2. The end-fed half wave is the same length as the dipole but consists of a single rod or whip fed at the bottom via a matching network. Mounting options are similar to those for the quarter-wave whip. A ground plane is sometimes used but is not essential. The end-fed arrangement is often preferred over the centre-fed dipole because it is easier to mount in the clear and above surrounding obstructions.

Yagi. This antenna consists of two or more elements mounted parallel to each other on a central boom. It is directional and exhibits gain but tends to be large and unwieldy – for these reasons the yagi is the ideal choice for links over fixed paths where maximum range is desired.

Module mounting considerations

Good RF layout practice should be observed. If the connection between module and antenna is more than about 20mm long use 50Ω microstrip line or coax or a combination of both. It is desirable (but not essential) to fill all unused PCB area around the module with ground plane.

PCB Layout and design notes:

- Leave 1mm all round module (i.e. PCB footprint area of 25x35mm)
- PCB holes - 1.2mm or socket strips
- Keep AF track away from RXD & TXD - to avoid cross talk.
- Put a test point on the AF pin for simple radio checking with a scope.
- Ground plane all unused PCB area around and under module.
- Position module and antenna as far from high speed logic and SMPS as possible
- Microprocessors with external data/address busses ALWAYS cause interference.
- Provide LED status lights on TX, RX & CD (direct or by plug on test PCB)
- For complex networks - provide software test routines for :-continuous RX, continuous TX, loop test, Simple master / slave "ping-pong".

Variants and ordering information

The ENX1 transceiver is manufactured in following frequency variants as standard:

Frequency: 169.40625MHz
169.44375MHz

ENX1-xxx-xxxx-3

For other variants please contact the factory.

Other variants can be supplied to individual customer requirements at frequencies from 120MHz to 180MHz

RF output can also be factory set from +5dBm (3mW) to +20dBm (100mW) depending on minimum order quantity.

Radiometrix Ltd

Hartcran House

231 Kenton Lane

Harrow, Middlesex

HA3 8RP

ENGLAND

Tel: +44 (0) 20 8909 9595

Fax: +44 (0) 20 8909 2233

sales@radiometrix.com

www.radiometrix.com

Copyright notice

This product data sheet is the original work and copyrighted property of Radiometrix Ltd. Reproduction in whole or in part must give clear acknowledgement to the copyright owner.

Limitation of liability

The information furnished by Radiometrix Ltd is believed to be accurate and reliable. Radiometrix Ltd reserves the right to make changes or improvements in the design, specification or manufacture of its subassembly products without notice. Radiometrix Ltd does not assume any liability arising from the application or use of any product or circuit described herein, nor for any infringements of patents or other rights of third parties which may result from the use of its products. This data sheet neither states nor implies warranty of any kind, including fitness for any particular application. These radio devices may be subject to radio interference and may not function as intended if interference is present. We do NOT recommend their use for life critical applications.

The Intrastat commodity code for all our modules is: 8542 6000

R&TTE Directive

After 7 April 2001 the manufacturer can only place finished product on the market under the provisions of the R&TTE Directive. Equipment within the scope of the R&TTE Directive may demonstrate compliance to the essential requirements specified in Article 3 of the Directive, as appropriate to the particular equipment.

Further details are available on The Office of Communications (Ofcom) web site:

<http://www.ofcom.org.uk/radiocomms/ifi/>

Information Requests

Ofcom

Riverside House

2a Southwark Bridge Road

London SE1 9HA

Tel: +44 (0)845 456 3000 or 020 7981 3040

Fax: +44 (0)20 7783 4033

information.requests@ofcom.org.uk

European Radiocommunications Office (ERO)

Peblingehus

Nansensgade 19

DK 1366 Copenhagen

Tel. +45 33896300

Fax +45 33896330

ero@ero.dk

www.ero.dk
