

## CTA88 chip based 2-channel I/O Application Boards

**The CTA88 chip is a simple encoder/decoder for use with ISM band telemetry modules. It permits a simple, one way wireless link to be established, for simple remote control applications, with a minimum of effort and no customer software input.**

**These tx and rx application boards are designed to allow easy evaluation of the CTA88 device in elementary jobs. They provide a simple 2 channel implementations, using either LMT/LMR or BiM footprint radio modules**



Figure 1: CTA28 application boards

### Range of Features

- 8 bit address and 2 bit data select switches
- 2 relays to control mains powered devices rated up to 8A, 250VAC/30VDC
- Visual indication of valid code received and active relays
- RF module range testing
- Push button for momentary control of relays
- Momentary, Latched outputs
- Dynamic relay state changes
- Setup is simple as Plug-and-Play
- RF Remote Control Demonstration

### Kit Contents

The CTA28 Application kit is supplied with the following contents:

- 2 CTA88-000-DIL
- 1 CTA28 Encoder board (ENC)
- 1 CTA28 Decoder board (DEC)
- 1 Radiometrix Transmitter module (*ordered separately*)
- 1 Radiometrix Receiver module (*ordered separately*)
- 2 1/4-wavelength monopole or helical antennas
- 2 Jumpers
- 1 CTA88 data sheet
- 1 CTA28 Application board manual
- 1 Data sheet of Radio module ordered

### Additional requirement

- External power supply or 12V DC power adaptor

Channels connected on the CTA chip are **zero** and **four** (for compatibility with rx mode 100, and serial operation)

## Common features:

Interfaces	
Input/output	2 x 3.81mm pitch 3 pin "Phoenix" two part connectors
Power	2.1mm connector and 2 pin "Phoenix" (these inputs are diode "or'ed" together). On/off slide switch on pcb
CTA88 mode	3 position jumpers
CTA88 address	8 position DIP switch
Radio channel	4 position DIP switch (optional)
Radio setup	2 pin 0.1" pitch "Molex" serial connection (optional)
RF	SMA(or optional screw terminal)
Indicators	
	Power on LED
	send/receiver LED
	2 x I/O pin state LEDs
CTA88	
	Clock 3.58MHz (ceramic resonator)
	Data rate 1kbit/sec Biphase coded burst
	Part: Leaded 28 pin, in socket
Size	
	87 x 70 x 16mm (excluding connectors)
	(four 3.3mm diameter mounting holes are provided)
Operating temperature	
	-20 to +70 degrees centigrade (some radios may be limited to -10/+55)
	(Storage -30 to +70 degrees)

## TX Application board

<b>Inputs</b>	2.5 to 50v (5mA) opto isolated inputs with manual "test" pushbuttons
	LED indicators on all channels
	Link selectable DC supply (5v aux, 5v main, or unregulated Vin) on each channel
	(fit one link only on jumpers JP10)
	Link selecting low power / normal mode (JP12)
<b>Supply</b>	6 –15V
<i>idle current:</i>	4mA (standard mode) 3uA (low power mode)
<i>transmit current</i>	(depends upon radio module fitted)
	50mA with LMT2-433-5 fitted
<b>Radio modules</b>	any LMT version
	transmitter versions of NiM2, BiM1, BiM1H, BiM2A, BiM3A/B RDL2 (tx). (Fit R32. Idle current increases by 10mA)

## TX application board jumpers and DIP switches

The TX encoder board has 4 jumpers and 2 DIP switches. The jumpers are used to select the number of operating modes featured in the board while the 4 way and 8 way DIP switches are used for frequency channels selection and address selection respectively.

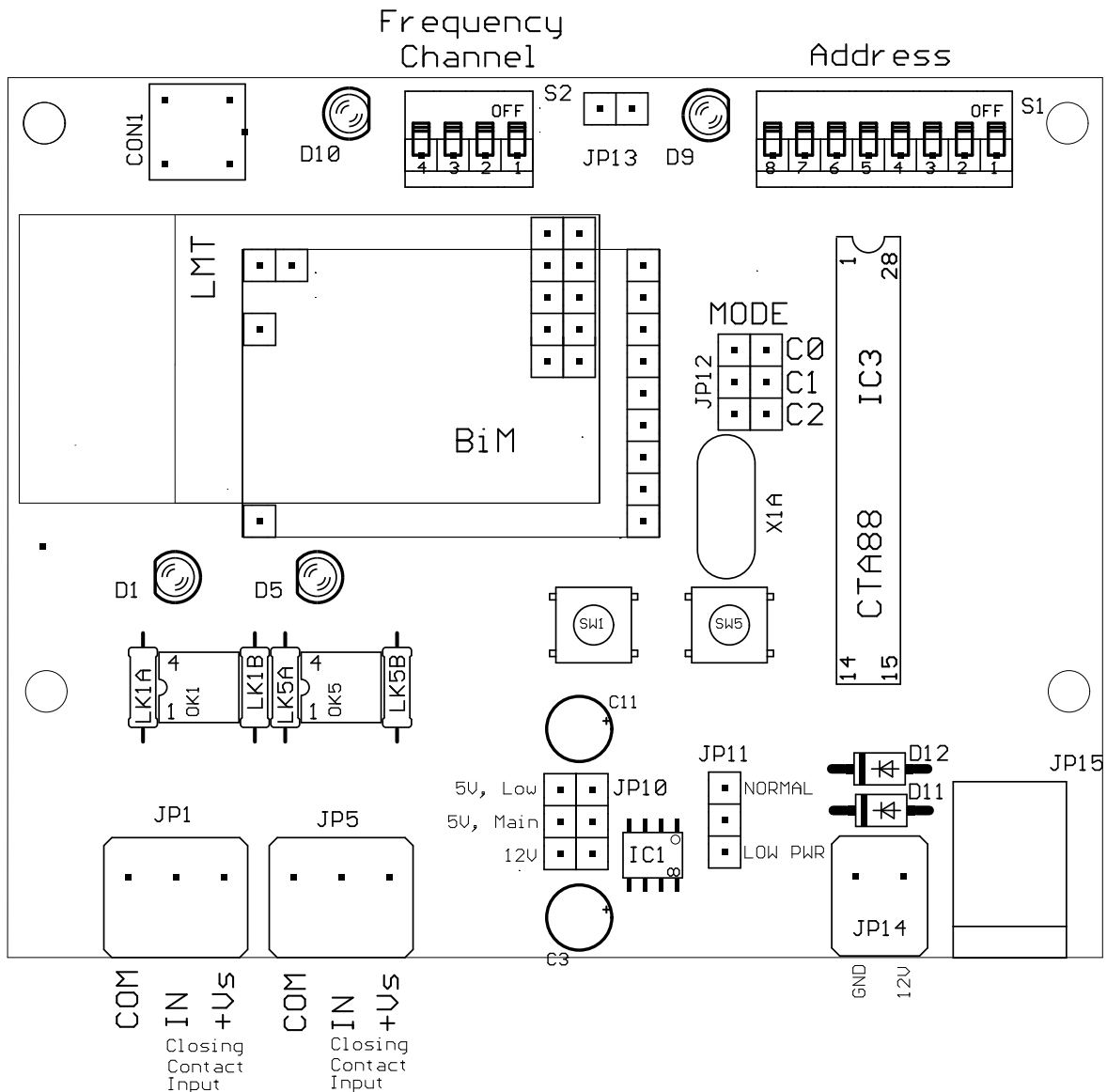

Figure 2: CTA28 TX application board PCB (top view)

## TX Jumpers

Assumed the board is held "long side horizontal" with the RF connector and DIP switches at the top

Jumper.	Name	Function	Position	Mode
JP10	SUPPLY	Selects which power supply is fed to the user inputs busbar (Only EVER fit one jumper on this header)	<b>Top</b>	Low current / always present +5v (100mA max, total) (default)
			<b>Middle</b>	Main +5v (250mA). In low power mode this rail is only Present during actuation
			<b>Bottom</b>	Unregulated Vin, via switch and 1A schottky diode

JP11	LOW POWER	Selects low power or normal mode Normal mode draws 5mA quiescent current: Low power draws 3uA, but if "low power" operation is selected then the coder device and transmitter are only activated when one of the inputs is "active". Therefore only modes 001 and 100 can be used with this option.	Up  Down	Normal  Low power (default)
JP12	MODE	Selects Operating modes	see operating mode section below	
JP13	RADIO SETUP	Radio setup (only for LM series radios)	Ground (GND) and the RS232 input to the PGM pin	
R32		Factory fitted for RDL2 (tx) use. Idle current increases by 10mA		

### TX DIP switches

The TX encoder board has 4 jumpers and 2 DIPswitches. The jumpers are used to select the number of operating modes featured in the board while the 4 way and 8 way DIP switches are used for frequency channels selection and address selection respectively.

### RX Application board

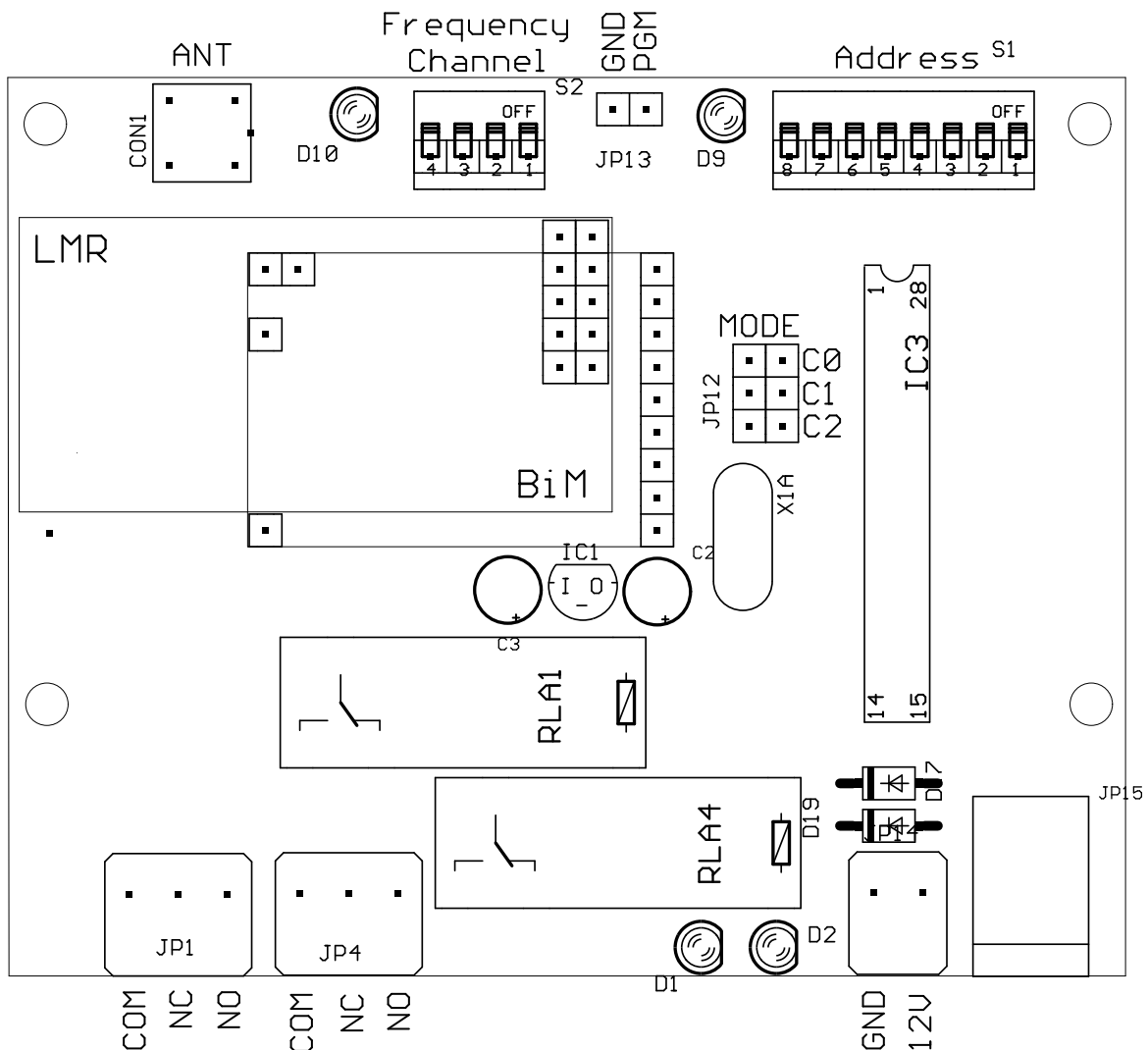

Figure 3: CTA28 RX application board PCB (top view)

<b>Outputs</b>	8amp 240v rated change over relay contacts
	LED indicators on both channels
<b>Supply</b>	12v (10-15v)
<i>receive/idle current</i>	(depends upon radio module fitted)
	23mA with LMR2-433-5 fitted
<i>relay current</i>	25mA per activated channel
<b>Radio modules</b>	any LMR version
	receive only versions of NiM2, BiM1, BiM2A, BiM3 (any)
	CVR1 (5v versions); RDL2 (rx)

## RX application board jumpers and DIP switches

The RX encoder board has 2 jumpers and 2 DIPswitches. As with TX board, the jumpers are used to select the number of operating modes featured in the board while the 4 way and 8 way DIP switches are used for frequency channels selection and address selection respectively.

Assumed the board is held "long side horizontal" with the RF and power connectors at the top

Jumper.	Name	Function	Position	Mode
JP12	MODE	Select Operating mode	(see operating mode section below)	
P13	PGM	Radio setup (only for LM series radios)	Ground (left) and the RS232 input (right)	

## RX application board DIP switches

The RX application board features a 4 way (S2) and an 8 way (S1) DIP switches. The optional 4 way DIP switch which is used for parallel frequency channel select is only required when our multi channel LM series radios like LMR1 / LMR2 s are used. The 8 way Dip switch is used to set an 8 bit (256) unit address.

## Operating modes

Device operation is set up by a 3 bit word, on the C0-C2 jumpers. This is JP12 on the boards

TX / Encoder modes	
000	Device is inactive
001	Send single burst, once only (on reset, and on each C0 low/high transition)
010	Send continuously
011	Send single burst on any change of Data input word
100	Send continuously while any Data input pin is high
101	Send a burst on average every 1.75 seconds. A P/N sequence generates a delay of 1 -2.5s between bursts
110	Serial mode (see notes)
111	Transmitter test. Send a constant 250Hz squarewave (C0=H, C1=H, C2=H)

RX / Decoder modes	
000	Local test. Data output word equals Address input word
001	Output last data received (150mS timeout)
010	Output last data (3 second timeout: see notes)
011	Hold last data received
100	D0-3 'set' corresponding bit, D4 resets D0, D5 resets D1 .. and so on
101	A '1' on any bit toggles the state of the corresponding output pin
110	Serial (see notes)
111	Link test. Data word outputs most recently received burst address

## Which modes to use?

The CTA88 have a variety of operating modes. These are better understood by relating them to different applications:

1. **Wire replacment:** Operate transmitter in mode 010 (continuous: allows the STB output to be used as a 'good link' indicator) and receiver in mode 001.

If receiver operates in latched (011) mode then 'chattering' of the output is reduced (at extreme range, or with interferers present), but the link is no longer fail safe

Latched mode is also compatible with send on change (011)

2. **Momentary push buttons:** Transmitter in mode 100 (send while any input is high), receiver in 001. Outputs remain high for as long as the button is held down. This is the mode one would choose to control (for instance) a pan/tilt head (D0= slew left, D1 = slew right, etc)

3. **Controlling four lights:** Use transmit mode 100 (send while high) or 011 (send on change), with the receiver in mode 100. This gives four outputs (D0-D3), each set by one transmitter input (D0-D3) and reset by another (D4-D7)

4. **Monitoring infrequent events** (such as door open/shut): Use transmitter in periodic transmit (101, to keep channel occupancy and power usage low), and receiver on 010 (3 second timeout), 011 (hold last burst) or 110 (serial data output, to a PC or data logging device).

In this mode the transmit duty cycle is less than 10% on average, and the variable delay between bursts permits same channel operation of several CTA88 links with minimum transmit collisions

5. **Send burst on trigger event:** Set transmitter to mode 000 (off) and use C0 line high as a 'strobe' line. A pulse between 100uS and 25mS with initiate a single transmission.

This gives an idea of the usable combinations, but with a little imagination others will be found

**Incompatibilities:** Certain operating modes are not compatible with some of the others:

**RX 101 (toggle)** doesn't work with TX 101 (periodic send) as the outputs switch on and off at the send rate

**RX 100 (set and reset)** doesn't work with TX 101 (as the response is sluggish) and doesn't need TX 010 (constant)

RX 101 (toggle) is also not best suited to extreme range operation, where the initiation can be a little sporadic.

(At extreme range, latched (011) or set/reset (100) are the best receiver modes, combined with TX 100 (send on any '1') as in this mode the failure of any single burst to be received matters less, as the operator can continue to operate the transmitter until the receiver actuates )

**Serial operation:** The CTA88 is capable of a very simple, single byte, serial link operation. It is selected by a '110' mode input.

This function is mainly intended for diagnostic work in the lab, but it does allow a pc to send or receive CTA88 command bursts. Address is still selected by the parallel inputs

**On the RX:** D4 = 'true' RS232 output (+ve = low (0), 0V = idle/mark state)  
D5 = 'inverted' RS232 output (+ve = idle/'mark' (1) state)  
D6 : high for 500uS before, and during, serial byte output

**On the TX** D4 = RS232 input  
D5 : low = set 'true' input polarity, high = set 'inverted' input polarity

In all cases a single 9600 baud byte is received or sent.

The link is not transparent: on the TX end the 'tx on' pin can be used as a 'busy' output

**Timeout:** In modes 001 and 010, the receiver outputs the last received data for a given period, before resetting D0-D7.

Any subsequent transmission will over-ride the current output state and reset the timer, even if the timeout period has not expired.

The short period is set to be slightly longer than the time between consecutive transmit bursts in a continuous mode.

The long timeout is usable with the randomised periodic transmission mode (101), as the 3 second timeout is longer than the longest delay between transmissions in this mode.  
 Versions of the chip can be supplied with this period extended to suit customer requirements

## **CTA28/CTA88 board: External input operation**

### **Option 1 (Default)**

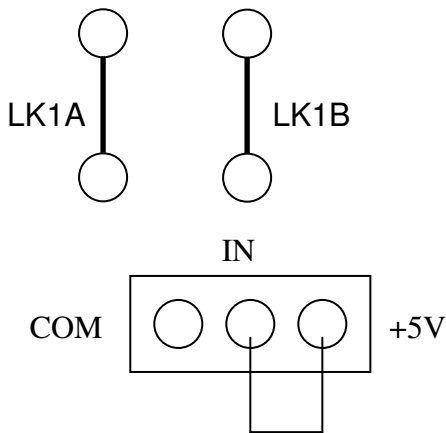

LK1A will link the COM to the system ground  
 LK1B will link the +5V to the +5V system rail.

So, just linking the IN and +5V inputs will trigger the operation. It is useful for sliding switch operation.

### **Option 2**

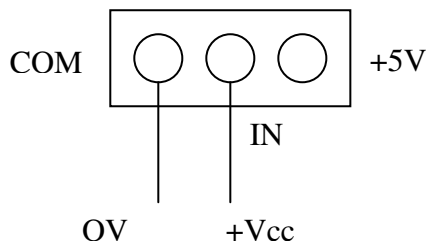

**COM:** Local ground (not connected to system ground)  
**IN :** 4mA Voltage sense  
**+5V:** +5V bias current

Connecting external supply to the COM and IN will trigger the operation

### **Option 3**

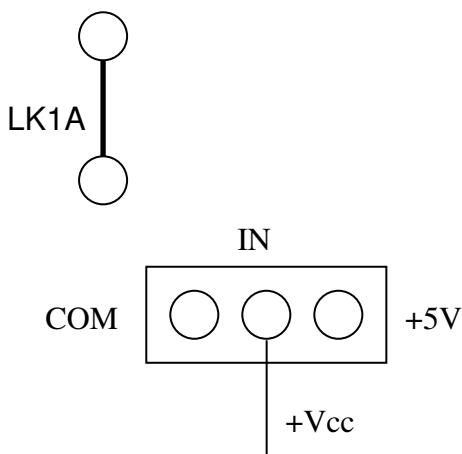

LK1A will link the COM to the system ground.

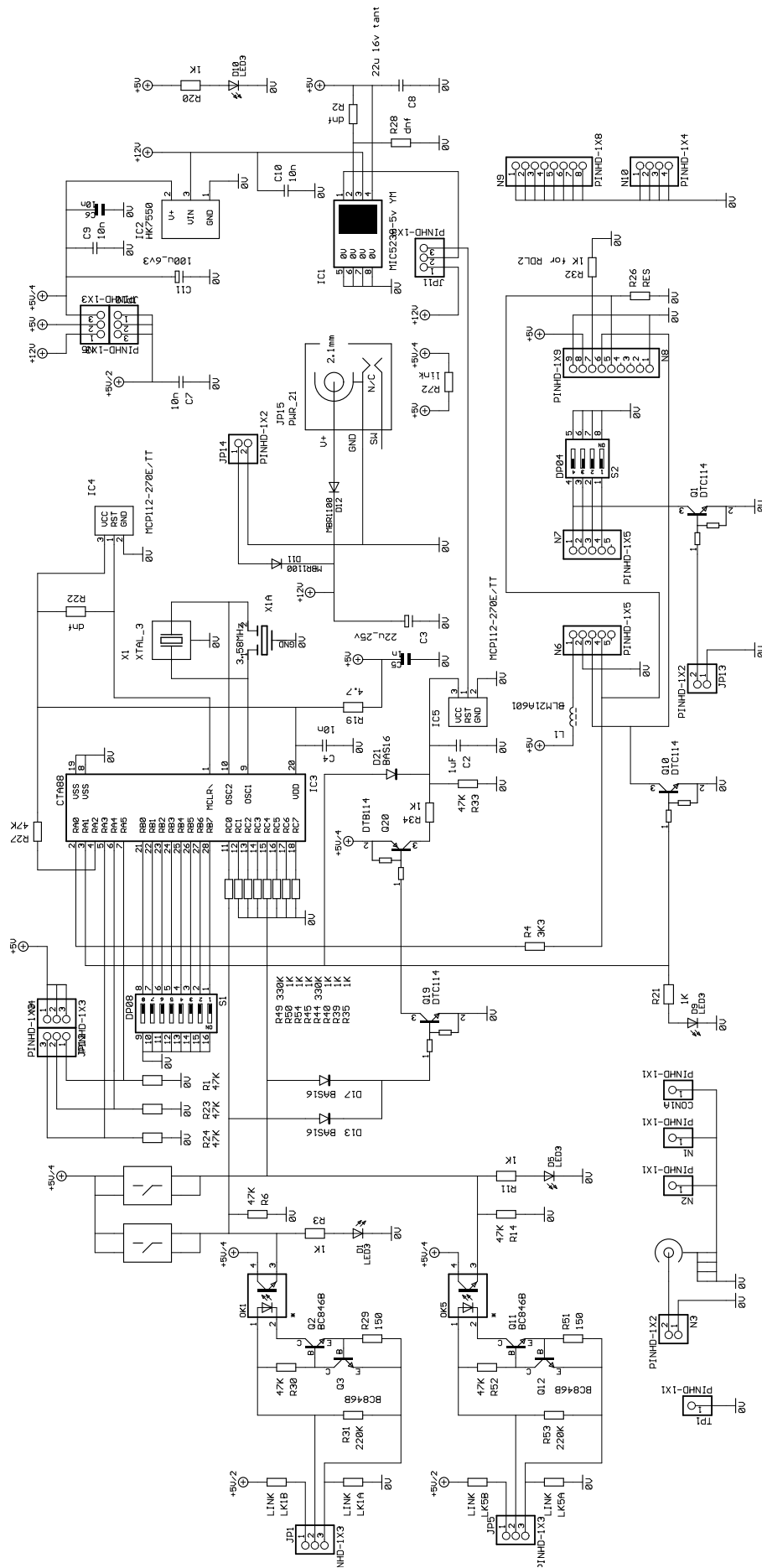

Figure 4: CTA28 Encoder Transmitter Schematics



## Ordering Information

Part No.	Version	Frequency band
CTA28-433-LMT2	LMT2 fitted encoder	433MHz
CTA28-433-LMR2	LMR2 fitted decoder	433MHz
CTA28-xxx-LMT2	LMT2 fitted encoder	Where xxx is UHF frequency
CTA28-xxx-LMR2	LMR2 fitted decoder	Where xxx is UHF frequency
CTA28-173-LMT1	LMT1 fitted encoder	173MHz
CTA28-173-LMR1	LMR1 fitted decoder	173MHz
CTA28-xxx-LMT1	LMT1 fitted encoder	Where xxx is VHF frequency
CTA28-xxx-LMR1	LMR1 fitted decoder	Where xxx is VHF frequency
CTA28-xxx-NiM2T	NiM2T fitted encoder	Where xxx is UHF operating frequency
CTA28-xxx-NiM2R	NiM2R fitted decoder	Where xxx is UHF operating frequency
CTA28-xxx-BiM1T	BiM1T fitted encoder	Where xxx is VHF operating frequency
CTA28-xxx-BiM1R	BiM1R fitted decoder	Where xxx is VHF operating frequency
<i>CTA28 application board can also be supplied with other BiM foot print radio modules fitted. e.g. BiM1H, BiM2A, BiM3A/B, RDL2 etc. Please contact sales for further details.</i>		

**Radiometrix Ltd**  
Hartcran House  
231 Kenton Lane  
Harrow, Middlesex  
HA3 8RP  
ENGLAND  
Tel: +44 (0) 20 8909 9595  
Fax: +44 (0) 20 8909 2233  
sales@radiometrix.com  
www.radiometrix.com

### **Copyright notice**

*This product data sheet is the original work and copyrighted property of Radiometrix Ltd. Reproduction in whole or in part must give clear acknowledgement to the copyright owner.*

### **Limitation of liability**

*The information furnished by Radiometrix Ltd is believed to be accurate and reliable. Radiometrix Ltd reserves the right to make changes or improvements in the design, specification or manufacture of its subassembly products without notice. Radiometrix Ltd does not assume any liability arising from the application or use of any product or circuit described herein, nor for any infringements of patents or other rights of third parties which may result from the use of its products. This data sheet neither states nor implies warranty of any kind, including fitness for any particular application. These radio devices may be subject to radio interference and may not function as intended if interference is present. We do NOT recommend their use for life critical applications.*

*The Intrastat commodity code for all our modules is: 8542 6000*

### **R&TTE Directive**

*After 7 April 2001 the manufacturer can only place finished product on the market under the provisions of the R&TTE Directive. Equipment within the scope of the R&TTE Directive may demonstrate compliance to the essential requirements specified in Article 3 of the Directive, as appropriate to the particular equipment.*

*Further details are available on The Office of Communications (Ofcom) web site:*

**<http://www.ofcom.org.uk/>**

Information Requests  
Ofcom  
Riverside House  
2a Southwark Bridge Road  
London SE1 9HA  
Tel: +44 (0)300 123 3333 or 020 7981 3040  
Fax: +44 (0)20 7981 3333  
information.requests@ofcom.org.uk

European Communications Office (ECO)  
Peblingehus  
Nansensgade 19  
DK 1366 Copenhagen  
Tel. +45 33896300  
Fax +45 33896330  
ero@ero.dk  
www.ero.dk