

UHF FM 400mW transceiver module

The BiM3H is a miniature PCB mounting UHF radio data transceiver incorporating a received signal strength indicator (RSSI). It allows the simple implementation of data links at speeds up to 10kbps and distances up to 5000 metres over open ground.



Figure 1: BiM3H-869.50-10

Features

- Designed to comply with harmonised radio standard EN 300 220-3
- Designed to comply with harmonised EMC standard EN 301 489-3
- Data rates up to 10kb/s
- Usable range up to 5000m
- Frequency 869.50MHz
- Fully screened
- Fast data settling time

Available for operation at 869.50MHz in the UK and Europe, the BiM3H combines full screening with internal filtering to ensure EMC compliance by minimising spurious radiation and susceptibility. The module suits one-to-one and multi-node wireless links in applications including car and building security, EPOS and inventory tracking, remote industrial process monitoring and computer networking. Because of the small size and low power requirements, the BiM3H is ideal for use in portable, battery-powered applications such as hand-held terminals.

Technical Summary

Receiver

- Single conversion FM superhet
- SAW front end filter gives >50dB image rejection
- 5 volt operation
- Current consumption 15mA
- -108dBm sensitivity @ 1ppm BER
- RSSI output with 50dB range
- Extremely low LO leakage, -125dBm typical

Transmitter

- Transmit power: 400mW (26dBm, +/- 1dB)
- Operating frequency 869.50MHz
- 5 volt operation
- Current consumption 310mA (typical)
- Data rate: 10 kbps

Evaluation platforms: NBEK + BiM / SMX carrier

BIM3H Single channel 400mW UHF transceiver

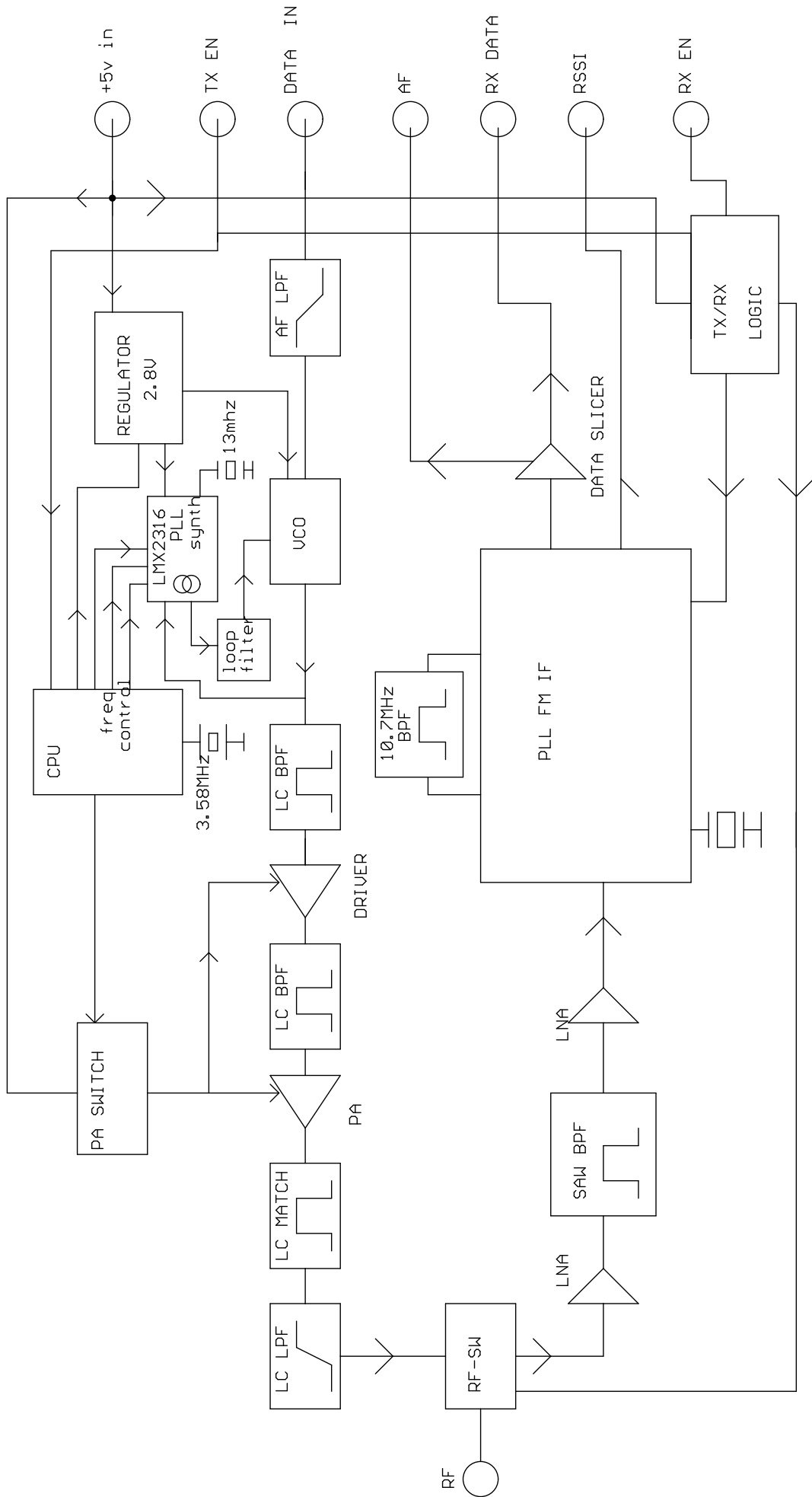

Figure 2: BIM3H block diagram

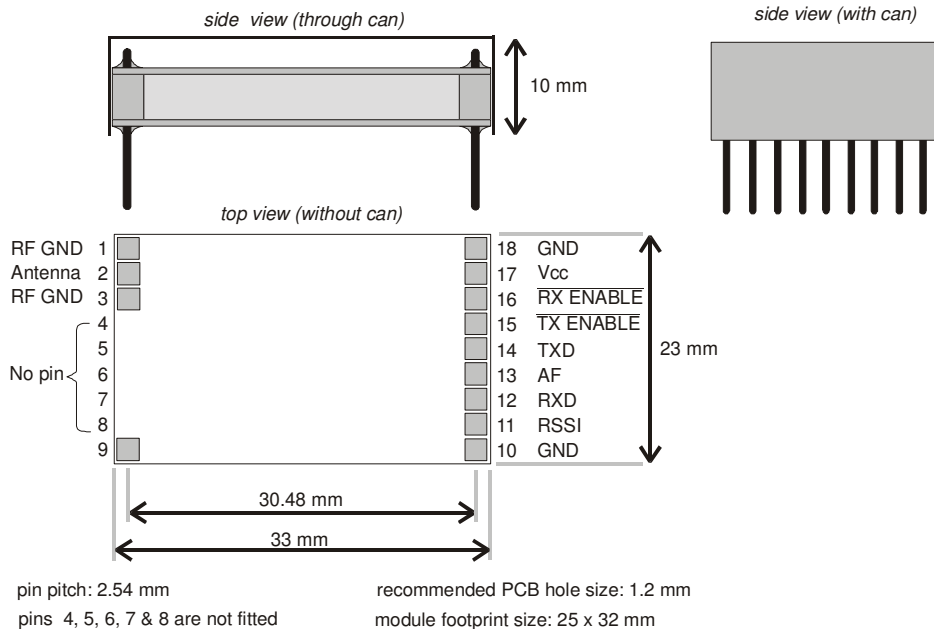

Figure 3: BiM3H Footprint (Top) view

Pin description

RF IN / OUT (pin 2)

50Ω input from the antenna, DC isolated.

RF GND (pin 1/3)

RF ground pin, internally connected to the module screen. This pin should be connected to the RF return path (coax braid, main PCB ground plane etc.)

0V (pin 9/18/10)

DC supply ground. Internally connected to pin 2 and module screen.

RSSI (pin 11)

Received signal strength indicator with 50dB range. See page 4 for typical characteristics.

RXD (pin 12)

Digital output from the internal data slicer. The data is a squared version of the signal on pin 13 (AF) and is true data, i.e. as fed to the transmitter. Output is “open-collector” format with internal 10kΩ pull-up to Vcc (pin 17).

AF out (pin 13)

Buffered and filtered analogue output from the FM demodulator. Standing DC bias 2V approx. External load should be >10kΩ // <100pF.

TXD (pin 14)

Dc coupled modulation input (5v logic)

TX enable (pin 15)

Transmitter enable pin, <0.5v

RX enable (pin 16)

Receiver enable pin, <0.5v

Vcc (pin 17)

DC supply. Max ripple content 0.1V_{p-p}.

NOTE: TX AND RX ENABLE SHOULD NOT BE OPERATED AT THE SAME TIME AS THIS COULD DAMAGE THE MODULE.

Absolute maximum ratings

Exceeding the values given below may cause permanent damage to the module.

Operating temperature	-20°C to +70°C
Storage temperature	-40°C to +100°C
Vcc (pin 17)	-0.1V to +5.5V
RSSI, AF, RXD (pins 11,13,12)	-0.1V to +3V
RF IN/OUT (pin 2)	□50V DC, +10dBm RF

Receiver Performance specifications

(Vcc = 5.0V / temperature = 20°C unless stated)

	pin	min.	typ.	max.	units	notes
DC supply						
Supply voltage	17	4.9	5.0	5.1	V	
Supply current	17	9	15	18	mA	1
RF/ IF						
RF sensitivity for 10dB (S+N/N)	1,2	-	-113	-	dBm	
RF sensitivity for 1ppm BER	1,2	-	-108	-	dBm	
RSSI range	11	-	50	-	dB	
IF bandwidth	-	-	180	-	kHz	
Image rejection	2	50	54	-	dB	
IF rejection (10.7MHz)	2	100	-	-	dB	
LO leakage, conducted	2	-	-125	-110	dBm	
Baseband						
Baseband bandwidth @ -3dB	13	0.1	-	7.8	kHz	
AF level	13	200	250	350	mV _{P-P}	2
DC offset on AF out	13	1.5	2	2.5	V	3
Distortion on recovered AF	13	-	1	5	%	3
Load capacitance, AFout/RXD		-	-	100	pF	
DYNAMIC TIMING						
Power up with signal present						
Power up to valid RSSI		-	0.5	1	ms	
Power up to stable data		-	2	10	ms	3
Signal applied with supply on						
RSSI response time (rise/fall)	11	-	100	-	µs	
Signal to stable data	12	-	0.5	1	ms	3
Time between data transitions		70	-	5000	µs	4
Mark:space ratio		20	50	80	%	5

Notes:

1. Current increases at higher RF input levels (>-20dBm and above).
2. For received signal with ±30kHz FM deviation.
3. Typical figures are for signal at centre frequency, max. figures are for ±50kHz offset.
4. For 50:50 mark to space ratio (i.e. squarewave).
5. Average over 30ms

Transmitter Performance specifications

(Vcc = 5.0V / temperature = 20°C unless stated)

	pin	min.	typ.	max.	units	notes
DC supply						
Supply voltage	17	4.9	5.0	5.1	V	8
Supply current	17		310		mA	
RF						
RF power output	2	25	+26	27	dBm	1
Spurious emissions, <1GHz	2	-	-	-54	dBm	2
Spurious emissions, >1GHz	2	-	-	-40	dBm	2
RF centre frequency	2	-	869.5	-	MHz	3
Initial frequency accuracy	2	-15	0	+15	kHz	
Overall frequency accuracy	2	-40	0	+40	kHz	4
FM deviation (peak)	2	-	+/-27	-	kHz	5
Antenna impedance	2	-	50	-	Ohms	
Baseband						
Baseband bandwidth @ -3dB	14	0.1	-	8	kHz	6
Maximum raw data rate	14	-	-	10	Kbps	6
TXD input level (logic low)	14	-	0		V	7
TXD input level (logic high)	14	-	5		V	7
DYNAMIC TIMING						
TX enable to full RF		-	53	55	ms	8

Notes:

1. Measured into 50 Ohm load
2. Meets EN requirements at all frequencies
3. There is a <10% duty cycle restriction on 869.50MHz in EU member states
4. Total over full supply and temperature range
5. With 0V – 5V modulation input
6. 5V CMOS compatible
7. To achieve specified FM deviation
8. Supply to Vcc must be constant and should not be used for power up of tx (use EN)

Power up timing for BiM3H

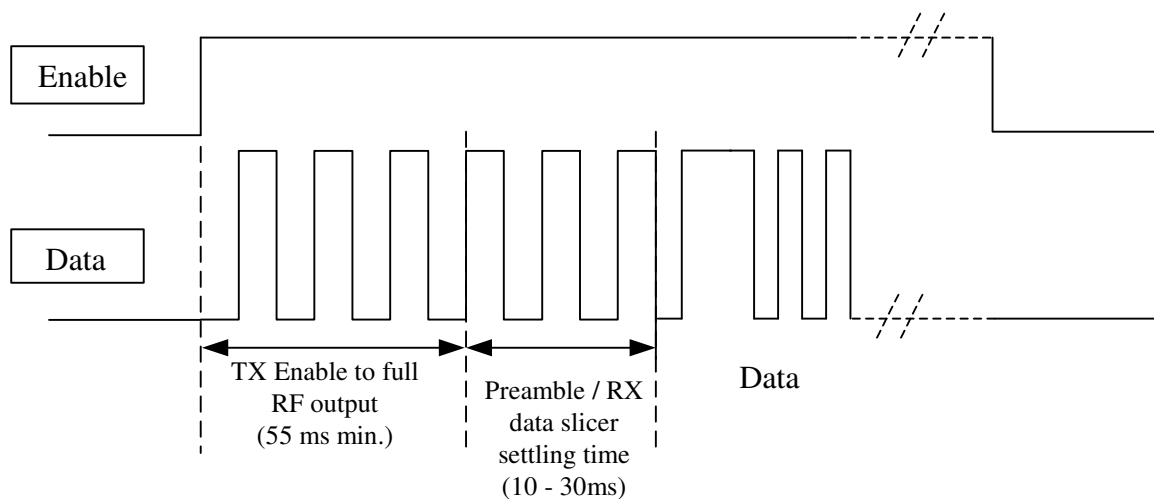

Figure 4: Typical timing diagram

Received Signal Strength Indicator (RSSI)

The module incorporates a wide range RSSI which measures the strength of an incoming signal over a range of approximately 50dB. This allows assessment of link quality and available margin and is useful when performing range tests.

The output on pin 11 of the module has a standing DC bias in the region of 0.5V with no signal, rising to around 1V at maximum indication. The RSSI output source impedance is high (~100k Ω) and external loading should therefore be kept to a minimum.

To ensure a fast response the RSSI has limited internal decoupling of 1nF to ground. This may result in a small amount of ripple on the DC output at pin 11 of the module. If this is a problem further decoupling may be added, in the form of a capacitor from pin 11 to ground, at the expense of response speed. For example, adding 10nF here will increase RSSI response time from 100 μ s to around 1ms. The value of this capacitor may be increased without limit.

Typical RSSI characteristic is as shown below:

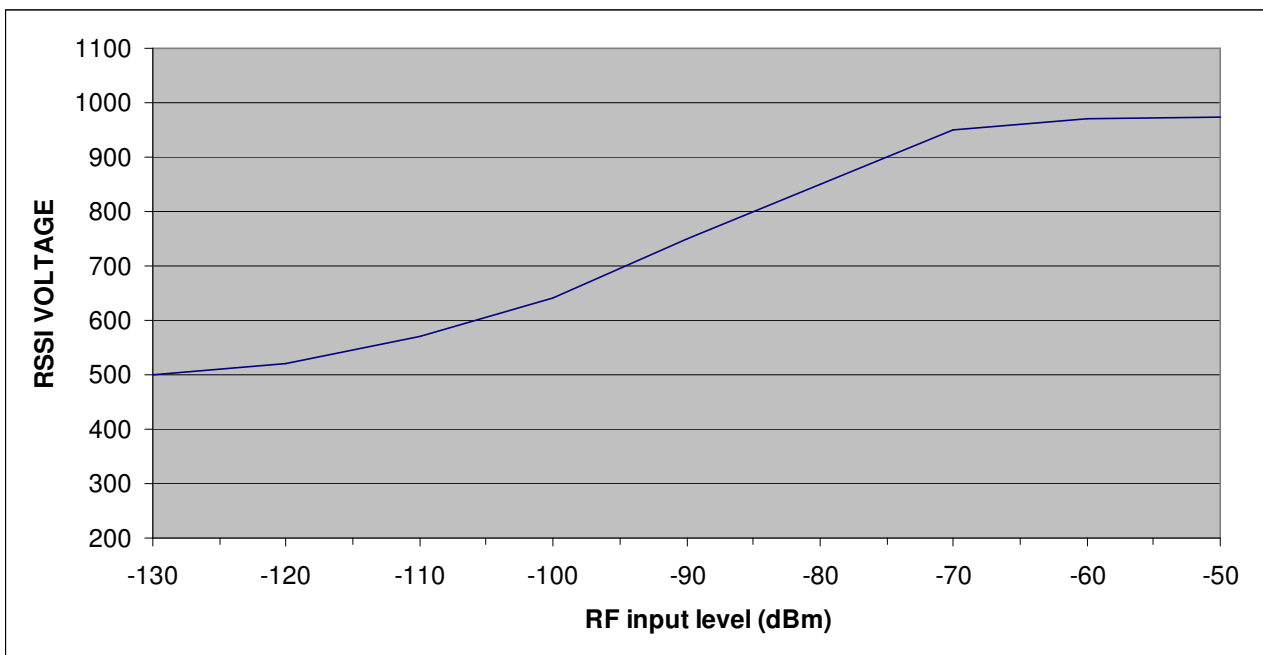

Fig.5: Typical RSSI response curve

Module mounting considerations

Good RF layout practice should be observed – in particular, any ground return required by the antenna or feed should be connected directly to the RF GND pin at the antenna end of the module, and not to the OV pin which is intended as a DC ground only. All connecting tracks should be kept as short as possible to avoid any problems with stray RF pickup.

If the connection between module and antenna does not form part of the antenna itself, it should be made using 50 Ω microstrip line or coax or a combination of both. It is desirable (but not essential) to fill all unused PCB area around the module with ground plane.

The module may be potted if required in a viscous compound which cannot enter the screen can.

Warning: DO NOT wash the module. It is not hermetically sealed.

Ordering information

BiM3H-869.50-10

CEPT/ERC Rec 70-03, 868 MHz Band Plan

Applications	Non-specific SRD	Alarm	Non-specific SRD	Social Alarm	Alarm	Non-specific SRD	Alarm	Non-specific SRD
Channel Spacing	No Spacing	25kHz or WB	No Spacing	25kHz	25kHz	25kHz or Wide Band	25kHz	No Spacing
Duty Cycle	<1% or LBT	<1%	<0.1% or LBT	<0.1%	<1%	<10% or LBT	<10%	up to 100%

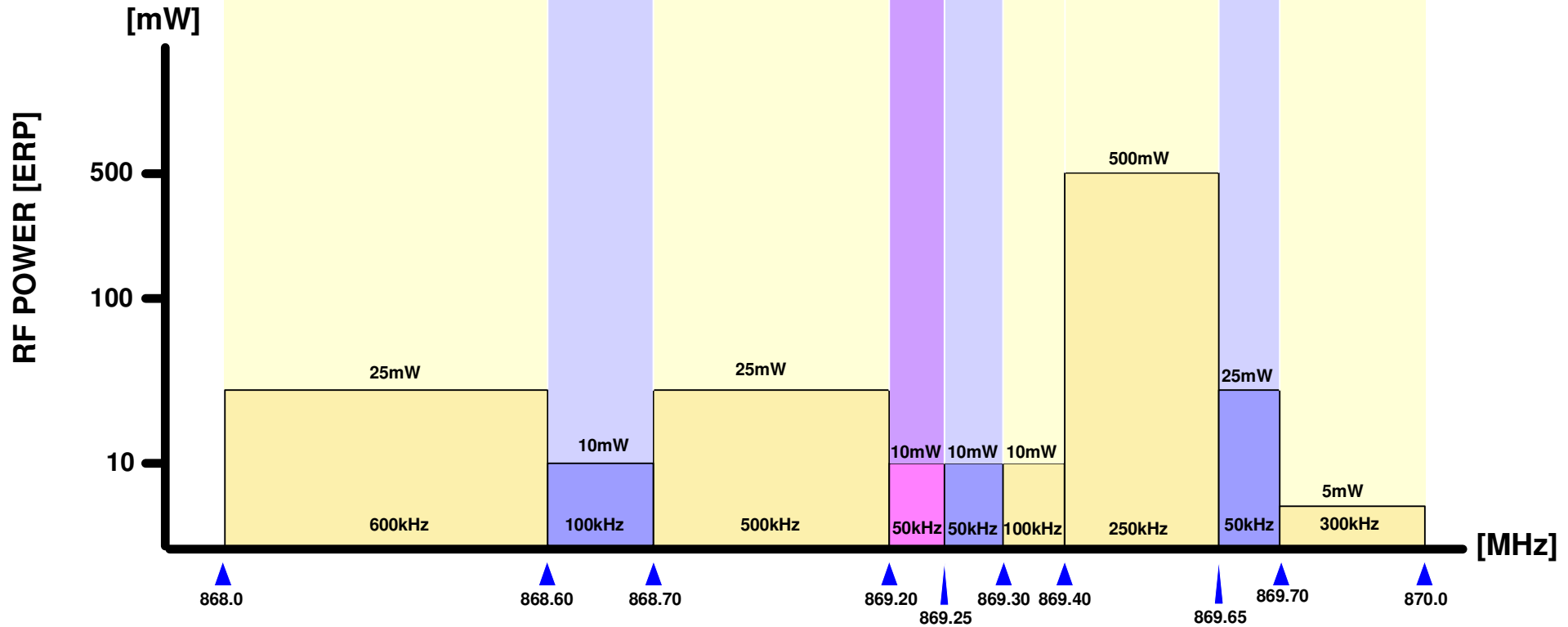

Radiometrix Ltd

Hartcran House
231 Kenton Lane
Harrow, Middlesex
HA3 8RP
ENGLAND

Tel: +44 (0) 20 8909 9595
Fax: +44 (0) 20 8909 2233
sales@radiometrix.com
www.radiometrix.com

Copyright notice

This product data sheet is the original work and copyrighted property of Radiometrix Ltd. Reproduction in whole or in part must give clear acknowledgement to the copyright owner.

Limitation of liability

The information furnished by Radiometrix Ltd is believed to be accurate and reliable. Radiometrix Ltd reserves the right to make changes or improvements in the design, specification or manufacture of its subassembly products without notice. Radiometrix Ltd does not assume any liability arising from the application or use of any product or circuit described herein, nor for any infringements of patents or other rights of third parties which may result from the use of its products. This data sheet neither states nor implies warranty of any kind, including fitness for any particular application. These radio devices may be subject to radio interference and may not function as intended if interference is present. We do NOT recommend their use for life critical applications.

The Intrastat commodity code for all our modules is: 8542 6000

R&TTE Directive

After 7 April 2001 the manufacturer can only place finished product on the market under the provisions of the R&TTE Directive. Equipment within the scope of the R&TTE Directive may demonstrate compliance to the essential requirements specified in Article 3 of the Directive, as appropriate to the particular equipment.

Further details are available on The Office of Communications (Ofcom) web site:

<http://www.ofcom.org.uk/>

Information Requests
Ofcom
Riverside House
2a Southwark Bridge Road
London SE1 9HA
Tel: +44 (0)300 123 3333 or 020 7981 3040
Fax: +44 (0)20 7981 3333
information.requests@ofcom.org.uk

European Communications Office (ECO)
Peblingehus
Nansensgade 19
DK 1366 Copenhagen
Tel. +45 33896300
Fax +45 33896330
ero@ero.dk
www.ero.dk