

NEW

Radiometrix

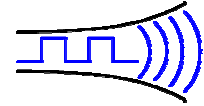

Hartcran House, 231 Kenton Lane, Harrow, HA3 8RP, England

Tel: +44 (0) 20 8909 9595, Fax: +44 (0) 20 8909 2233

Issue 1, 30 April 2007

TXL2/RXL2

UHF Multi Channel Transparent Data Link TX/RX

The TXL2 and RXL2 modules are 9600baud simplex multi channel OEM radio modems in a Radiometrix SIL standard footprint, operating on European 433MHz ISM band. The TXL2/RXL2 pair act as a transparent serial cable to attached host. Unlike raw FM radio modules (e.g. TX2A/RX2A), TXL2/RXL2 will take care of preamble, synchronisation, bit balancing and error checking along with automatic noise squelching.



Figure 1: TXL2-433-9 / RXL2-433-9

The TXL2/RXL2 pair provides a one-way radio link. Provided no two devices attempt to transmit simultaneously no further restrictions on data transmission need be made, as all transmit timing, valid data identification and datastream buffering is conducted by the units. Synchronisation and framing words in the packet prevent the receiver outputting garbage in the absence of wanted RF signal or presence of interference. For multiple radio systems a TXL2/RXL2 can be set to 1 of 8 unique addresses. As well as having unique addresses, the TXL2/RXL2 allow operation on one of 5 pre-set frequencies in the 433MHz band. These frequencies are non-overlapping and simultaneous operation of TXL2/RXL2 pairs in the same area on different channels will be possible. Units are supplied on 433.925MHz (Ch0) as default.

Features

- Conforms to EN 300 220-3 and EN 301 489-3
- High quality, stable crystal reference
- Low noise synthesiser / VCO
- SAW front-end filter
- Multi-stage ceramic IF filtering
- Single conversion superhet
- Serial modem baud rate at 9600bps (simplex)
- Addressable point-to-point
- 5 serial select wideband channels

Applications

- PDAs, organisers & laptops
- Handheld / portable terminals
- EPOS equipment, barcode scanners
- In-building environmental monitoring and control
- Remote data acquisition system, data logging
- Fleet management, vehicle data acquisition

Technical Summary

- Operating frequency: 433.925MHz (default)
- Modulation: 16kbps bi-phase FSK
- Supply: 5V at 28mA transmit, 22mA receive/idle
- Transmit power: +10dBm (10mW)
- Receiver sensitivity: -107dBm (for 1% BER)
- 32 byte data buffer
- Adjacent channel rejection: 60db @ ± 320 kHz
- Receiver Blocking: >75dB

TXL2-433-9

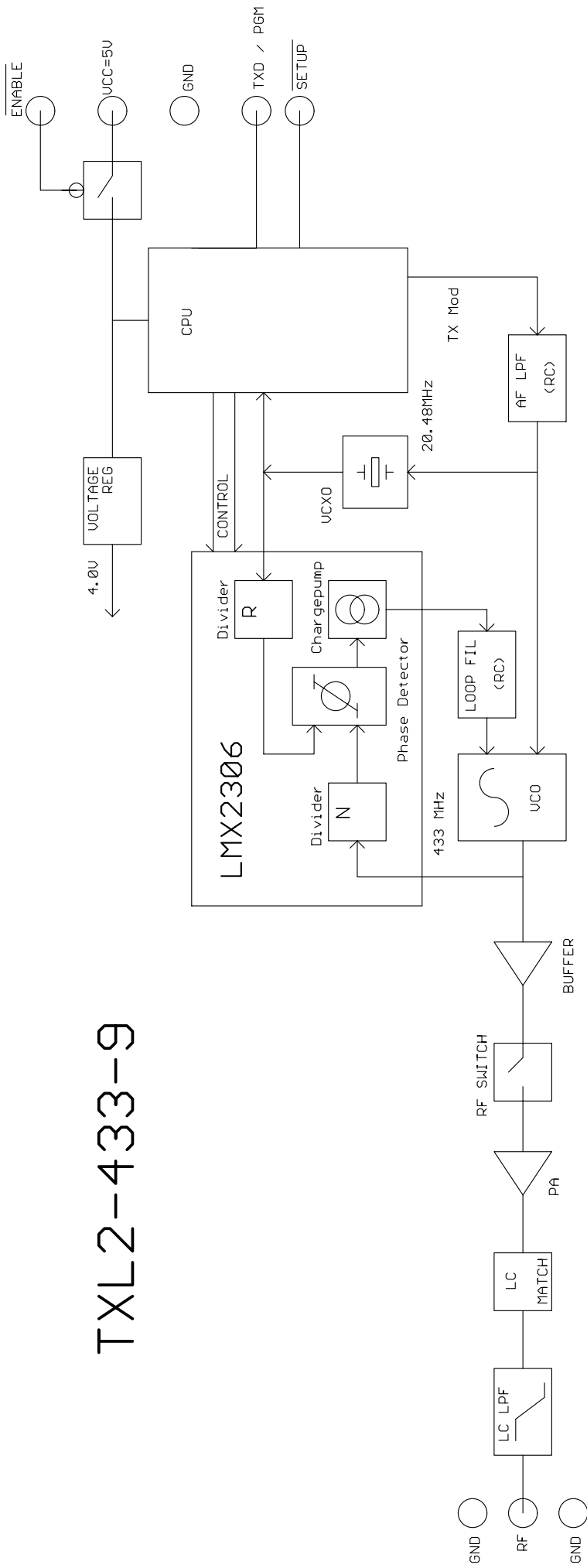

Figure 2: TXL2 block diagram

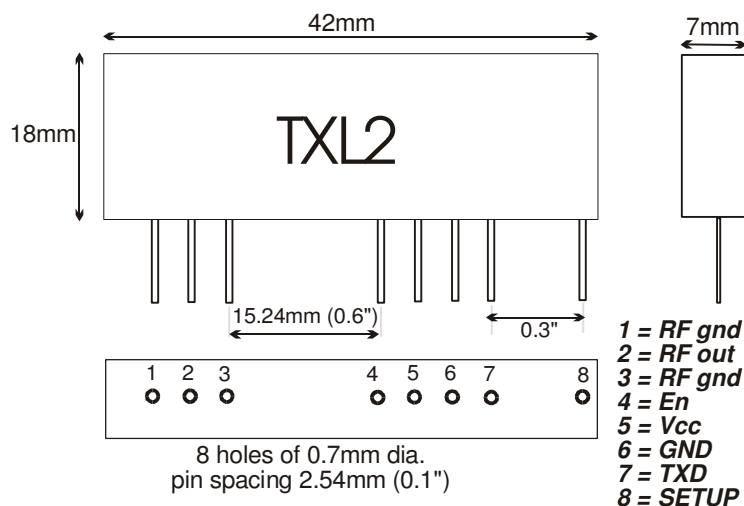

Figure 3: TXL2 footprint

TXL2 Pin description

Pin	Name	Function
1	RF GND	RF ground
2	RF out	50Ω RF output to the antenna
3	RF GND	RF ground
4	EN	Pull high to enable module (may be tied to Vcc)
5	Vcc	5V regulated power supply (4.75 – 5.25V)
6	GND	Supply ground
7	TXD	Inverted RS232 input (5V CMOS logic, No pullup)
8	TEST/SETUP	Pull low to enter test/setup mode (5V CMOS logic, Pullup to 5V)

Notes:

1. TEST has 47K pullup to Vcc. TXD has none. EN has a 47K pulldown
2. Vcc must be a 5v regulated supply (4.75 - 5.25v)
3. Pinout is similar to TX1H, with the addition of pin 8 (located 7.62mm on from pin 7)
4. TXD is inverted RS232 at 5v cmos levels. To connect to a true RS232 device, inverting a level shifter must be used (MAX232 type are ideal, but simple NPN transistor switches with pullups often suffice). With typical microcontrollers and uarts, direct connection is possible.
5. The TXL2 provides transmit side of a simplex link, but provided no two devices attempt to transmit at one time, no further restrictions on data transmission need be made, as all transmit timing, valid data identification and datastream buffering is conducted by the unit. There is no 'transmit enable' pin.
6. This unit is compatible with the RXL2 receiver and the TDL2A transceiver
7. A simple addressing structure is included in the datastream. Units may be programmed onto one of eight addresses (all units are supplied set to default ADDR=0 and default channel=0, 433.925MHz)

RXL2-433-9

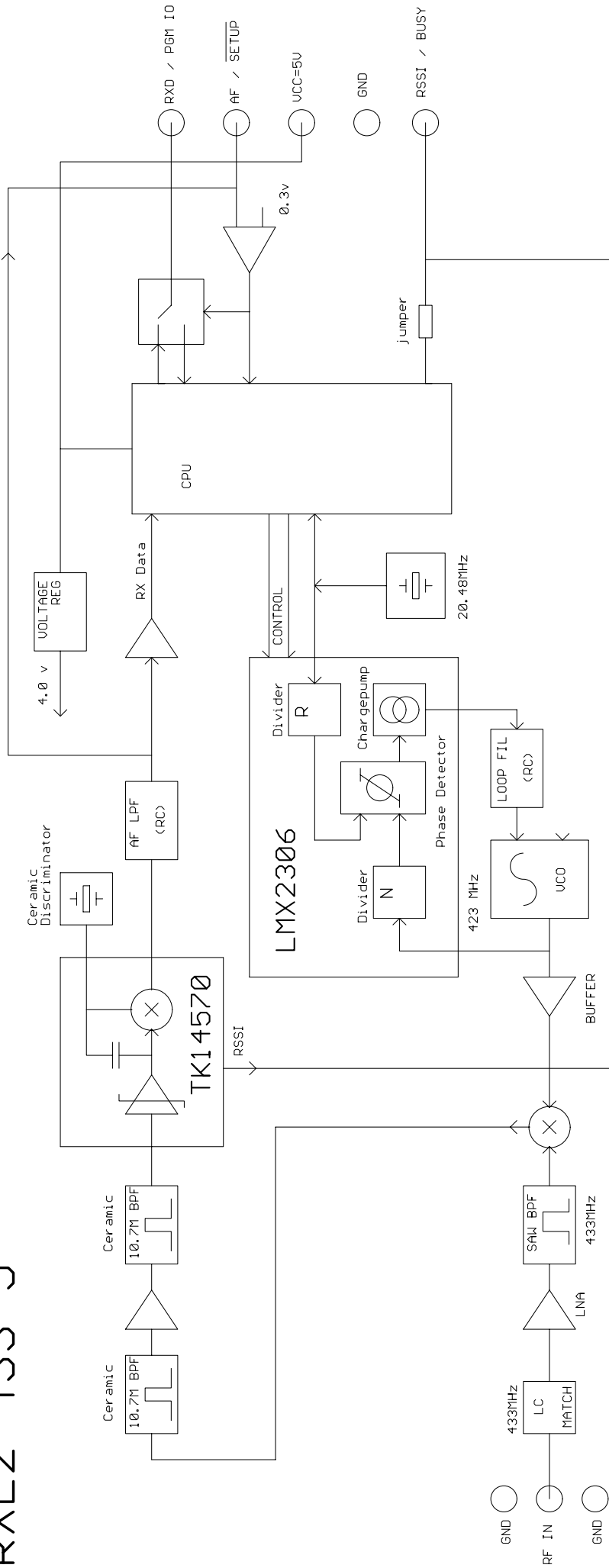

Figure 4: RXL2 block diagram

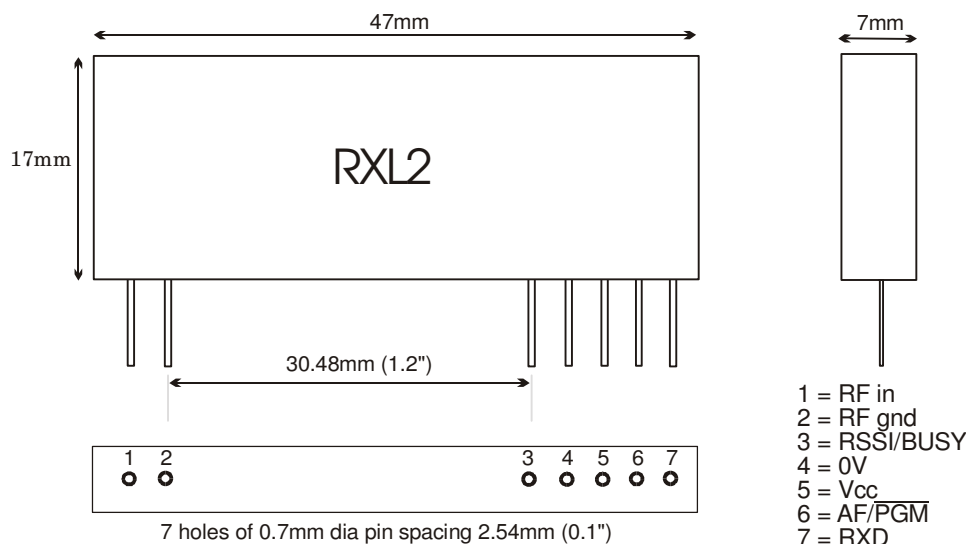

Figure 5: RXL2 footprint

RXL2 Pin description

Pin	Name	Function
1	RF in	50Ω RF input from the antenna
2	RF GND	RF ground
3	RSSI/BUSY	S meter or BUSY output
4	0V	Supply ground
5	Vcc	5V regulated power supply (4.75 – 5.25V)
6	AF/PGM	Baseband audio (or PGM in)
7	RXD	Receive Data (Inverted RS232 at 5V CMOS logic level); Input in PGM mode

Notes:

- To enter program mode, the AF/PGM pin must be tied to ground (V_{pin} below 0.3v: jumper or open collector recommended). Normally this pin functions as a high impedance (20K) receiver baseband audio output
- Vcc must be a 5v regulated supply (4.75 - 5.25v)
- Pinout is as RX2A
- RXD is inverted RS232 at 5v cmos levels. To connect to a true RS232 device, inverting level shifters must be used (MAX232 type are ideal, but simple NPN transistor switches with pullups often suffice). With typical microcontrollers and uarts, direct connection is possible. The same pin is used for normal operation Data out, PGM mode data in, and PGM mode data out.
- The RXL2 provides a receive side of a simplex link. Provided no two devices attempt to transmit at one time, no further restrictions on data transmission need be made, as all transmit timing, valid data identification and datastream buffering is conducted by the unit.
- This unit is compatible with the TXL2 transmitter and the TDL2A transceiver.
- A simple addressing structure is included in the datastream. Units may be programmed onto one of eight addresses (all units are supplied set to default addr=0) and one of five RF channels (supplied default is channel=0, 433.925MHz)
- RSSI pin can be changed to a 'BUSY' (= valid data in FIFO) logic output by a solder blob link on the back of the pcb, otherwise it functions as a signal strength output (0 - 1.4v)

Condensed specifications

Frequency	433.925MHz – CHAN0 (default channel) 433.285MHz – CHAN1 433.605MHz – CHAN2 434.245MHz – CHAN3 434.565MHz – CHAN4
<i>Frequency stability</i>	±10kHz
<i>Channel width</i>	320kHz
<i>Number of channels</i>	1 of 5, user programmed
Supply Voltage	5V
<i>Current</i>	TXL2: 25mA transmit, 8mA idle (EN active / high, no activity on TXD) RXL2: 22mA receive/idle
Operating temperature	-20 °C to +70 °C (Storage -30 °C to +70 °C)
Spurious radiations	Compliant with ETSI EN 300 220-3 and EN 301 489-3
Interfaces	0.1" pitch SIL pins
Size	TXL2: 43 x 19 x 7 mm RXL2: 47 x 17 x 7 mm

<i>TXL2 Transmitter</i>	
Output power	10dBm (10mW) ±1dB
TX on switching time	<4ms
Modulation type	16kbps bi-phase FSK
FM peak deviation	+/-25KHz
Adjacent channel TX power	<-37dBm
TX spurious	<-45dBm
<i>RXL2 Receiver</i>	
Sensitivity	-107dBm for 1% BER
image	-50dB
spurious / adjacent channel	-65dB
Blocking	-84dB nominal, 75dB worst case
LO re-radiation	<-60dBm
<i>Interface</i>	
Data rate	9600baud, Simplex
Format	1 start, 8 data, 1 stop, no parity
Levels	5V CMOS (inverted RS232. Mark = 5V = idle)
Buffers	32 byte FIFO
Flow control	None
Addressing	1 of 8, user programmed
Data latency	14ms (first byte into TX, to first byte out of RX)

Serial interface – modem operation

To connect to a true RS232 device, inverting RS232-CMOS level shifters must be used. Maxim MAX232 or equivalent are ideal, but simple NPN transistor switches with pull-ups often suffice. With typical microcontrollers and UARTs, direct connection is possible.

The Radio / data stream interface

A 32 byte software FIFO is implemented in both the transmit and receive sub-routine. At the transmitting end this is used to allow for the transmitter start up time (about 3mS), while on receiving end it buffers arriving packets to the constant output data rate. All timing and data formatting tasks are handled by the internal firmware. The user need not worry about keying the transmitter before sending data as the link is entirely transparent.

For transmission across the radio link data is formatted into packets, each comprising 3 bytes of data and a sync code. If less than 3 bytes are in the transmit end FIFO then a packet is still sent, but idle codes replaces the unused bytes. When the transmit end FIFO is completely emptied, then the transmitter is keyed off.

Operation: Radio interface.

Raw data is not fed to the radios. A coding operation in the transmit sub-routine, and decoding in the receiver, isolate the AC coupled, potentially noisy baseband radio environment from the datastream.

The radio link is fed a continuous tone by the modem. As in bi-phase codes, information is coded by varying the duration consecutive half-cycles of this tone. In our case half cycles of 62.5us and 31.25us are used. In idle (or 'preamble') state, a sequence of the longer cycles is sent (resembling an 8KHz tone).

A packet comprises the Synchronising (or address) part, followed by the Data part, made up of twelve Groups (of four half cycles duration). Each Group encodes 2 data bits, so one byte is encoded by 4 Groups.

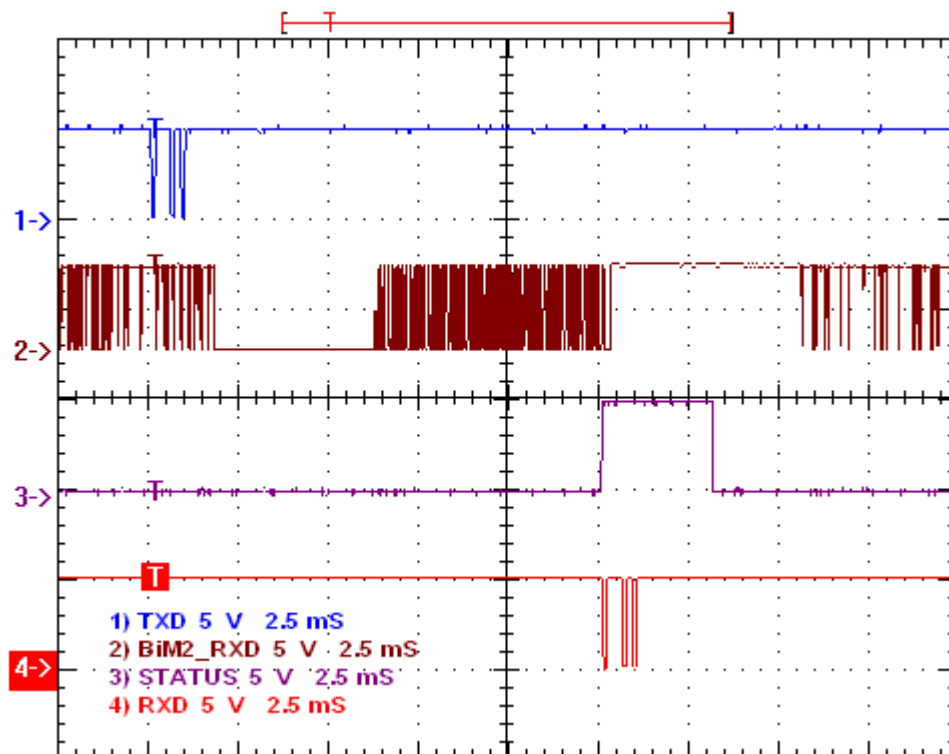

Figure 6: transmitted and received data

The oscilloscope screen capture shows a single byte being transmitted by TXL2. A BiM2-433-64 transceiver is used to capture the transmitted data. The character appears on the serial data output (RXD) pin of the RXL2 after about 12.5ms. Busy (STATUS) pin is momentarily set high to indicate the presence of a valid data in the receive buffer of the RXL2.

It can be clearly seen that unlike raw radio modules, RXL2 does not output any noise when there is not any transmission. Data fed into the TXD input of a TXL2 transmitter appears at the RXD output of a RXL2 receiver within radio range in the original form it was fed.

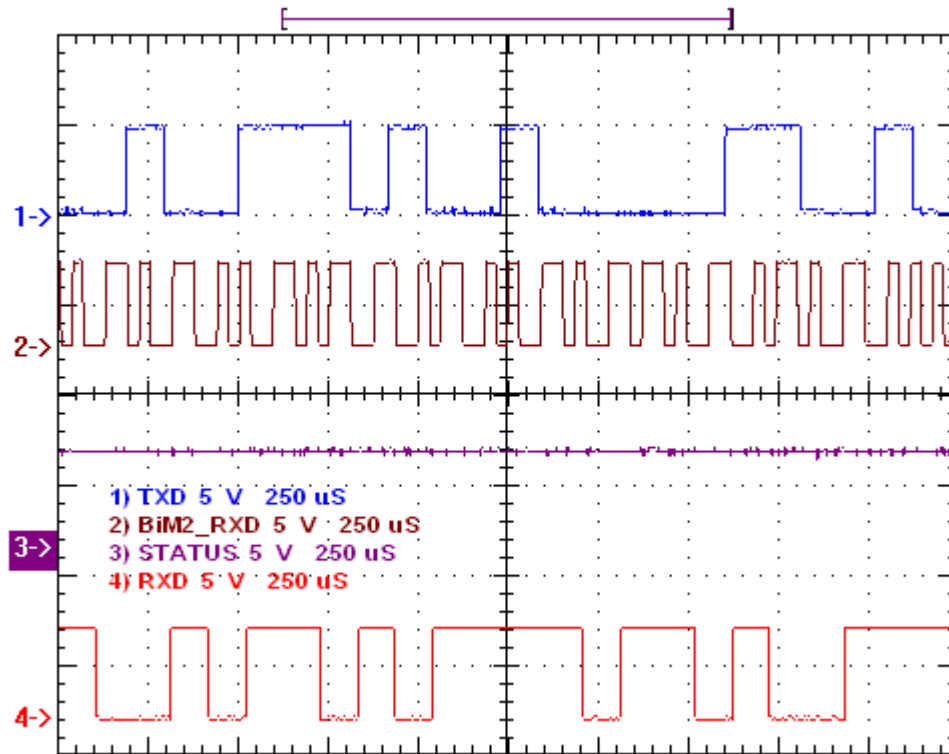

Figure 7: 16kbps Bi-phase encoded continuous data stream (expanded view)

Continuous serial data at 9600bps (above) is encoded as half-cycles of 8kHz (62.5µs long bit) and 16kHz (31.25µs short bit).

Programming the TXL2/RXL2

In order to use all the functions embedded in the TXL2/RXL2, the user must be aware of the setup/programming facility, which allow different addresses and frequency channels to be set up, and if necessary accesses diagnostic test modes.

Both modules are programmed through the same RS232 port that is used for sending/receiving data. An RS232 terminal emulator (such as Aterm or HyperTerminal) is an ideal tool.

TXL2 and RXL2 can be put to program mode by pulling the TEST and PGM pins respectively.

The unit will only respond to certain command strings:

ADDR0 to **ADDR7** <CR>: These commands set up one of 8 unique addresses.
CHAN0 to **CHAN4** <CR>: These commands select one of 5 preset channels

A TXL2 will only communicate with an RXL2 unit set to the same address and the same channel.

Address and channel numbers are stored in volatile memory. On power-up both will revert to the default in EEPROM (as supplied this is always address 0 and Channel 0)

SETPROGRAM <CR>: Writes the current address and current channel into EEPROM as the new default.
 A tilde character (~, ascii 126dec) sent by the unit indicates end of EEPROM write sequence

(these commands are normally only used for factory diagnostics)

- NOTONE** <CR>: Transmit unmodulated carrier
- LFTONE** <CR>: Transmit carrier modulated with 8KHz squarewave
- HFTONE** <CR>: Transmit carrier modulated with 16KHz squarewave
- #** <CR>: Transmitter off

A Carriage Return '<CR>' (00Dhex) should be entered after each command sequence to execute it.

Releasing the TEST and PGM pins to high state return the modules to normal operation.

Application circuits

Interfacing a microcontroller to TXL2/RXL2

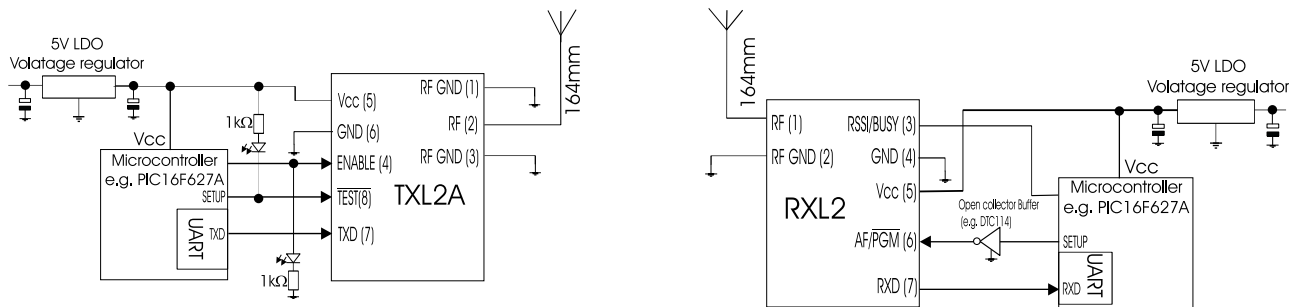

Figure 8: TXL2 and RXL2 interfaced directly to a microcontroller

TXL2 and RXL2 can be directly interfaced to any microcontrollers. If the microcontroller has a built-in UART, it can concentrate on its main task and leave the packet formatting, bit balancing and error checking of serial data to TXL2/RXL2.

Serial data should be in the following format:

- 1 start bit, 8 data bits, no parity, 1 or 2 stop bits
- 9600bps
- 0V=low, 5V=high

BUSY pin (in RXL2) can be connected to one of the port pins which can generate an interrupt on low-to-high transition (e.g. RB0/INT pin in the PIC). This can be used to enter a receive sub-routine to download data received from remote TXL2. Therefore, the host does not need to wait in a loop for a packet.

Interfacing RS232 port to TXL2/RXL2

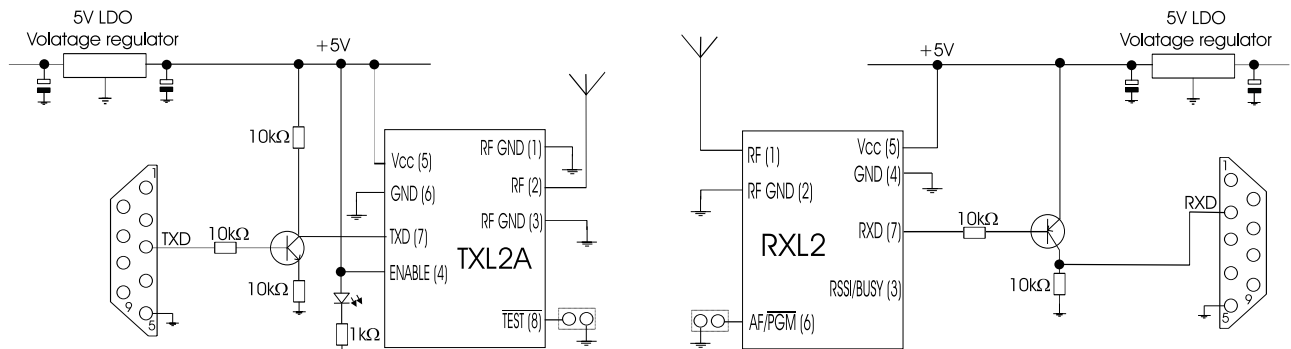

Figure 9: TXL2 /RXL2 interfaced to an RS232 port via an RS232 line driver /receiver

Some DTE hosts assert DTR signal when they are active and this can be used via RS232 line receiver to enable TXL2. Otherwise the ENABLE must be physically pulled-low to activate the TXL2.

Antenna requirements

Three types of integral antenna are recommended and approved for use with the module:

- A) **Whip** This is a wire, rod ,PCB track or combination connected directly to RF pin of the module. Optimum total length is 16cm (1/4 wave @ 433MHz). Keep the open circuit (hot) end well away from metal components to prevent serious de-tuning. Whips are ground plane sensitive and will benefit from internal 1/4 wave earthed radial(s) if the product is small and plastic cased
- B) **Helical** Wire coil, connected directly to RF pin, open circuit at other end. This antenna is very efficient given it's small size (20mm x 4mm dia.). The helical is a high Q antenna, trim the wire length or expand the coil for optimum results. The helical de-tunes badly with proximity to other conductive objects.
- C) **Loop** A loop of PCB track tuned by a fixed or variable capacitor to ground at the 'hot' end and fed from RF pin at a point 20% from the ground end. Loops have high immunity to proximity de-tuning.

	A	B	C
	<i>whip</i>	<i>helical</i>	<i>loop</i>
Ultimate performance	***	**	*
Easy of design set-up	***	**	*
Size	*	***	**
Immunity proximity effects	*	**	***

The antenna choice and position directly controls the system range. Keep it clear of other metal in the system, particularly the 'hot' end. The best position by far, is sticking out the top of the product. This is often not desirable for practical/ergonomic reasons thus a compromise may need to be reached. If an internal antenna must be used, try to keep it away from other metal components, particularly large ones like transformers, batteries and PCB tracks/earth plane. The space around the antenna is as important as the antenna itself.

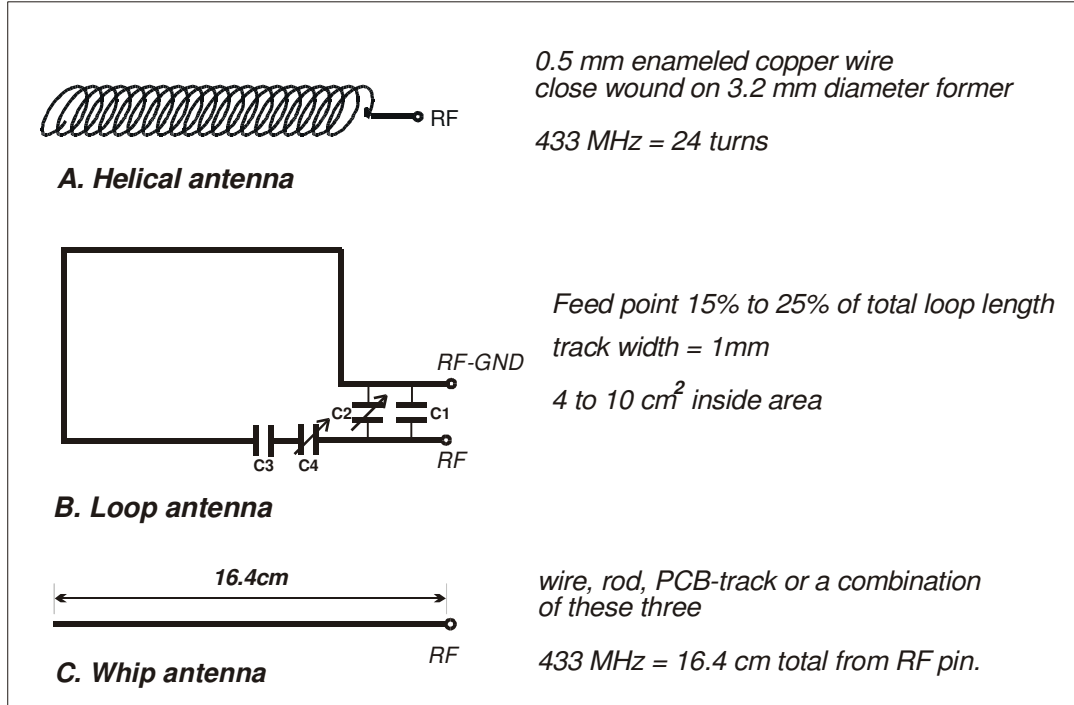

Figure 10: Antenna types

Ordering information

The TXL2/RXL2 modems are manufactured in the following variants as standard:

Part Number	Frequency band	Maximum baud rate
TXL2-433-9	433.925 - 434.565 MHz	9.6kbps
RXL2-433-9	433.925 - 434.565 MHz	9.6kbps
TXL2-433-4	433.925 - 434.565 MHz	4.8kbps
RXL2-433-4	433.925 - 434.565 MHz	4.8kbps

Radiometrix Ltd
Hartcran House
231 Kenton Lane
Harrow, Middlesex
HA3 8RP
ENGLAND
Tel: +44 (0) 20 8909 9595
Fax: +44 (0) 20 8909 2233
sales@radiometrix.com
www.radiometrix.com

Copyright notice

This product data sheet is the original work and copyrighted property of Radiometrix Ltd. Reproduction in whole or in part must give clear acknowledgement to the copyright owner.

Limitation of liability

The information furnished by Radiometrix Ltd is believed to be accurate and reliable. Radiometrix Ltd reserves the right to make changes or improvements in the design, specification or manufacture of its subassembly products without notice. Radiometrix Ltd does not assume any liability arising from the application or use of any product or circuit described herein, nor for any infringements of patents or other rights of third parties which may result from the use of its products. This data sheet neither states nor implies warranty of any kind, including fitness for any particular application. These radio devices may be subject to radio interference and may not function as intended if interference is present. We do NOT recommend their use for life critical applications. The Intrastat commodity code for all our modules is: 8542 6000.

R&TTE Directive

After 7 April 2001 the manufacturer can only place finished product on the market under the provisions of the R&TTE Directive. Equipment within the scope of the R&TTE Directive may demonstrate compliance to the essential requirements specified in Article 3 of the Directive, as appropriate to the particular equipment. Further details are available on The Office of Communications (Ofcom) web site:

<http://www.ofcom.org.uk/radiocomms/ifi/>

Information Requests
Ofcom
Riverside House
2a Southwark Bridge Road
London SE1 9HA
Tel: +44 (0)845 456 3000 or 020 7981 3040
Fax: +44 (0)20 7783 4033
information.requests@ofcom.org.uk

European Radiocommunications Office (ERO)
Peblingehus
Nansensgade 19
DK 1366 Copenhagen
Tel. +45 33896300
Fax +45 33896330
ero@ero.dk
www.ero.dk