

LMT2 / LMR2

Issue 1, 21 January 2013

UHF Narrow Band FM Low Cost multi channel

The LMT2 transmitter and LMR2 receiver modules offer a multi channel, low power, and reliable data link. This makes the LMT2/LMR2 pair ideally suited to those low power applications where existing wideband modules have insufficient range, or where low cost multi-channel operation is needed without compromising on RF specification or regulatory requirement.



Figure 1: LMT2 transmitter and LMR2 receiver

Features

- Conforms to EN 300 220-3 and EN 301 489-3
- High performance double superhet. PLL synthesizer with TCXO
- quasi-dc (peak sampling) data recovery circuit (for enhanced performance on unbalanced datastreams)
- SAW front-end filter
- Data rates up to 5 kbps for standard module
- Usable range over 1km
- Fully screened. Low profile
- Feature-rich interface (RSSI, analogue and digital baseband)
- Re-programmable via RS232 interface
- Low power requirements

Applications

- Handheld terminals
- EPOS equipment, barcode scanners
- Data loggers
- Industrial telemetry and telecommand
- In-building environmental monitoring and control
- High-end security and fire alarms
- DGPS systems
- Vehicle data up/download
- Heavy vehicle/machinery controls

Technical Summary

- Operating frequency: 433.875-434.650MHz (EU band)
458.525 - 459.1MHz (UK band)
- Other custom UHF bands
- 32 channels
- Transmit power: +10dBm (10mW) / +20dBm (100mW)
- Supply range: 3.1 – 15V (TX @ 10mW and RX), 4.1 – 15V (TX @ 100mW)
- Current consumption: 34mA @ 10mW, 90mA @ 100mW (transmit) and 20mA (receive)
- Data bit rate: 5kbps max. (standard module)
- Receiver sensitivity: -118dBm (for 12 dB SINAD)
- Serial configuration by inverted RS232 at 3V CMOS level

Evaluation platforms: NBEK + LM Series carrier

LMT2 10mW narrowband transmitter

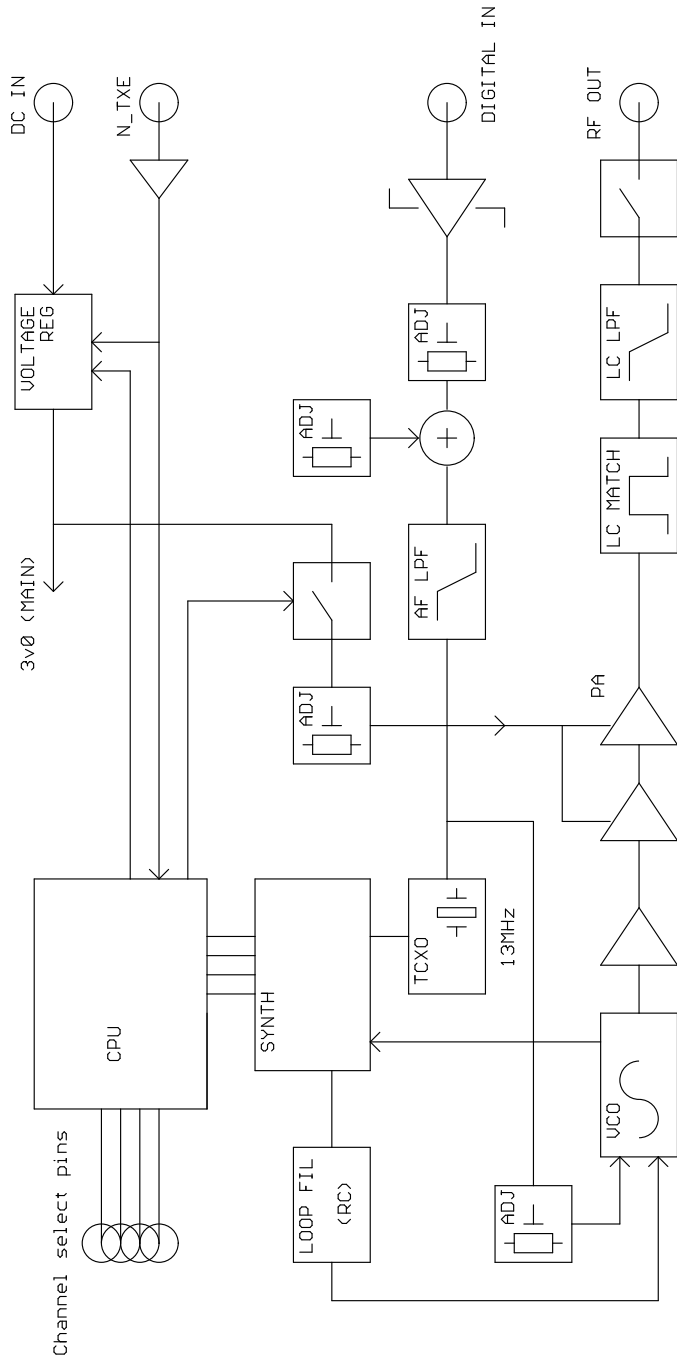

Figure 2: LMT2 block diagram

LMR2 narrowband receiver

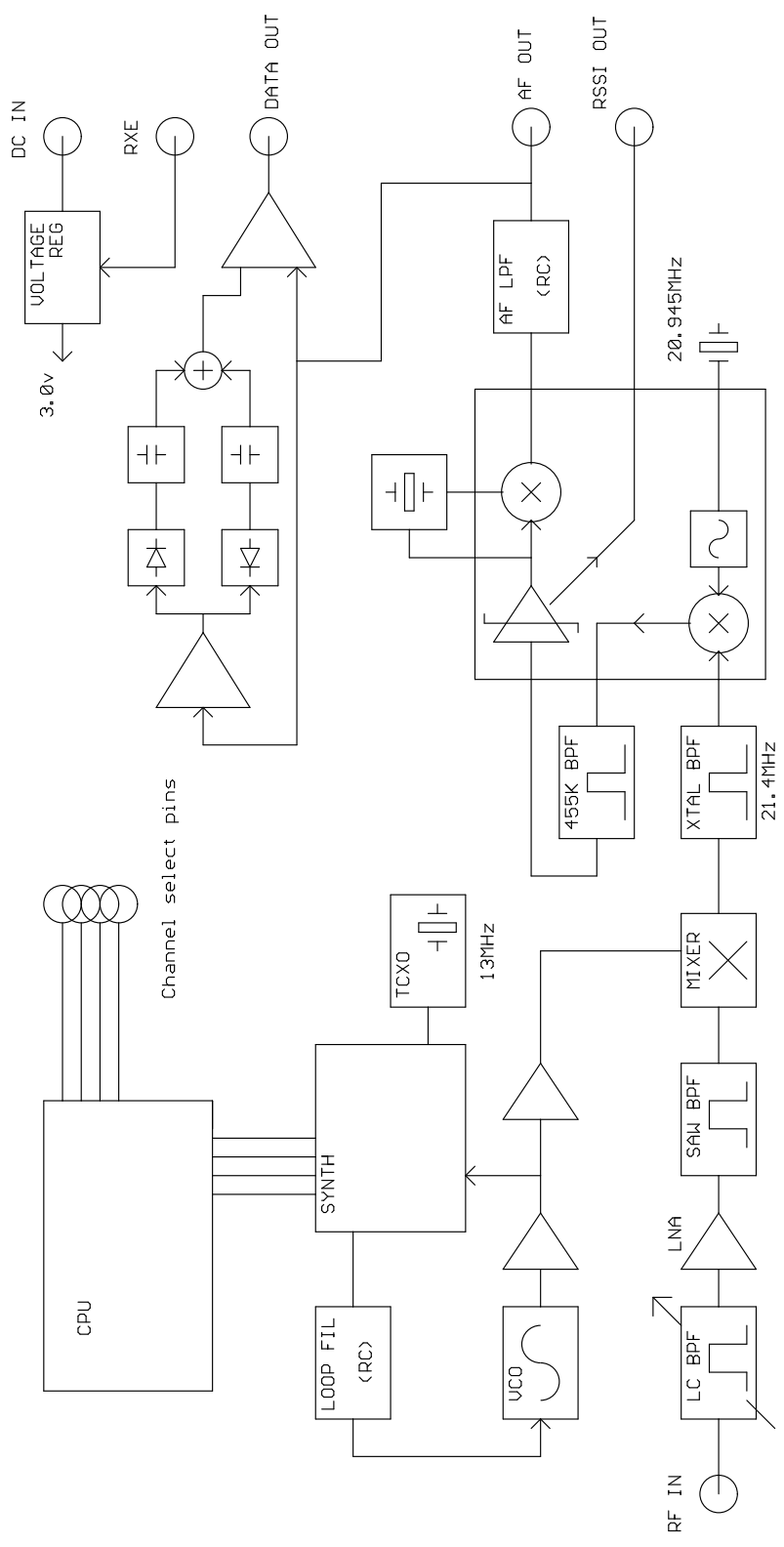

Figure 4: LMR2 block diagram



Figure 5: LMR2 footprint (top view)

Pin description – LMR2

Pin	Name	Function
1a	Vcc	3.1 – 15V power supply
2a	0V	Ground
3a	RXE	Receiver Enable (active high)
4a	RXD	Data out (open collector, no pullup)
5a	AF out	700mV p-p audio. DC coupled, approx 0.8v bias.
1b	P0/PGM	Parallel Channel select LSB Serial frequency programming / configuration ¹
2b	P1	Parallel Channel select
3b	P2	Parallel Channel select
4b	P3	Parallel Channel select MSB
5b	RSSI	DC level between 0.5v and 2.2v. 60dB dynamic range

NOTES:

1. Serial programming is by an inverted, cmos logic level, 2400 baud RS232 datastream applied to the P0 pin.
2. Channel select inputs have pullups (50kΩ) to 3v internal rail. Do not exceed 3v logic levels on this port.
3. Channel select inputs are active low
4. All pins are on an 0.1" grid
5. Data recovery circuit used for RXD is not a simple 'average and compare' type. It is a peak sampling quasi-DC coupled design, allowing a greater than usual flexibility in data format.
6. Unit will operate (with marginally reduced specifications) from a 3.0v rail. This must be well regulated and without noise or ripple, as in this state the unit's internal regulator no longer operates, and provides no supply rejection.

Serial interface commands

2400 baud RS232. 8 bit data, no parity, 1 start bit, 1 or 2 stop bits.

Serial data is sent to the unit on one of the parallel channel select pins (P0). It is very important that the unit does not 'decode' switch bounce in ordinary operation as a command string, or spurious re-writing of the e2prom will result. For this reason the user must send the 16 character string ENABLESERIALMODE (followed by a carriage return) to activate the serial command mode before sending any of the command strings listed below. Command mode is disabled on power down, or on reception of a # character. To successfully program the unit, it must be enabled ('RXE high (rx) or TXE low (tx)).

GOCHAN aa	Serially select channel aa, where aa is ch0 to ch31
LOAD aa nnnnn	Set value of N register for channel aa, where aa is Channels 0 to 31
SETPAR	Channel selected by 4 bit parallel inputs (ch0 to ch15 only)
SETSER	Channel selected by most recent GOCHAN operation
RVALUE rrrr	Set value for R register
SINGLE nnnnn	Set value of N for single channel operation. N value NOT stored in EEPROM
<cr>	Process entry
/	Clear all buffers
#	Disable command mode

aa = a two digit channel number from 00 to 31

nnnnn = synthesizer N register value (up to 65535)

rrrr = synthesizer R register value (up to 16383)

$$N_{TX} = \frac{f_{RF}}{f_{Channelspacing}} = \frac{433.900MHz}{25kHz} = 17356 \quad R = \frac{f_{TCXO}}{f_{channelspacing}} = \frac{13MHz}{25kHz}, \text{ So } R=520$$

$$N_{RX} = \frac{f_{RF} - 21.4MHz}{f_{Channelspacing}} = \frac{433.900MHz - 21.4}{25kHz} = 16500$$

Note: A pause of at least 50ms must be allowed between command strings (EEPROM programming time).

SINGLE mode does not store the N value in EEPROM. Therefore the unit is inoperative after a power down until either another valid SINGLE command is received, or mode is changed by a GOCHAN, SETPAR or SETSER command. SINGLE mode is intended for frequency agile applications.

LMT2, LMR2 channels are spaced at 50kHz interval into two frequency groups. 50kHz spacing between sequential channels minimises adjacent channel interference.

e.g. 433MHz band

Serial or Parallel channel select	Frequency (MHz)	Serial channel select	Frequency (MHz)
		16	433.875
0 (P3:P0 = HHHH)*	433.900		
		17	433.925
1	433.950		
		18	433.975
2	434.000		
		19	434.025
3	434.050		
		20	434.075
4	434.100		
		21	434.125
5	434.150		
		22	434.175
6	434.200		
		23	434.225
7	434.250		
		24	434.275
8	434.300		
		25	434.325
9	434.350		
		26	434.375
10	434.400		
		27	434.425
11	434.450		
		28	434.475
12	434.500		
		29	434.525
13	434.550		
		30	434.575
14	434.600		
		31	434.625
15 (P3:P0=LLLL)*	434.650		

Note: Parallel select pins: H=3V, L= 0V

Condensed specifications

Frequency	433MHz EU band, and 458MHz UK band As supplied: EU version: 433.875 - 434.65MHz (25kHz steps) UK version 458.525 - 459.1MHz (25kHz steps) Other custom UHF bands
<i>Frequency stability</i>	±1.5kHz
<i>Channel spacing</i>	25kHz
<i>Number of channels</i>	16 channels controlled by parallel port or 32 via RS232 interface
Operating temperature	-10 °C to +60 °C (Storage -30 °C to +70 °C)
Spurious radiations	Compliant with ETSI EN 300 220-3 and EN 301 489-3
Transmitter	
Output power	+10dBm (10mW) ±1dB (factory adjustable 1 - 25mW) +20dBm (100mW) ±1dB (factory adjustable 25 - 100mW)
Peak deviation	±3kHz
TX on switching time	30ms from TXE transition
Modulation type	FSK (F3D)
TX modulation bandwidth	DC – 5kHz (3V CMOS compatible)
Adjacent channel TX power	<-37dBm
TX spurious	<-45dBm (no RF output in Standby)
<i>Supply</i>	
Voltage	3.1V – 15V (1-25mW) 4.1 – 15V (25 – 100mW)
Current	34mA @ 10mW (nominal) 65mA @ 50mW (nominal) 90mA @ 100mW (nominal) <5µA standby (TXE high or floating)
Inputs	data (CMOS/TTL compatible)
Size	33 x 23 x 9mm
Interface	<i>User</i> 10 (8) pin 0.1" pitch dual row (5+5) header <i>RF</i> 2pin 0.1" pitch
Recommended PCB hole size	1.2mm
Receiver	
Sensitivity	-118dBm for 12dB SINAD
S/N ratio	35dB (min), 40dB (typ) on AF output
AF bandwidth (-3dB)	4kHz
image	<-60db
Othr spurious	<-70dbm
Blocking	Better than 84dB
Adjacent channel	<-60dB
LO re-radiation	-70dBm
<i>Supply</i>	
Voltage	3.1V – 15V
Current	20mA receive <1µA standby (RXE low)
Outputs	RSSI, audio, data (quasi DC data recovery circuit)
Size	46 x 23 x 9 mm
Interface	<i>User</i> 10 pin 0.1" pitch dual row (5+5) header <i>RF</i> 2pin 0.1" pitch
Recommended PCB hole size	1.2mm

RX Received Signal Strength Indicator (RSSI)

The LMR2 has wide range RSSI that measures the strength of an incoming signal over a range of 60dB or more. This allows assessment of link quality and available margin and is useful when performing range tests.

The output on pin 5b of the module has a standing DC bias of up to 0.5V with no signal, rising to 2.5V at maximum indication (RF input levels of -40dBm and above). $\Delta V_{min-max}$ is typically 2V and is largely independent of standing bias variations. Output impedance is 40k Ω . Pin 5b can drive a 100 μ A meter directly, for simple monitoring.

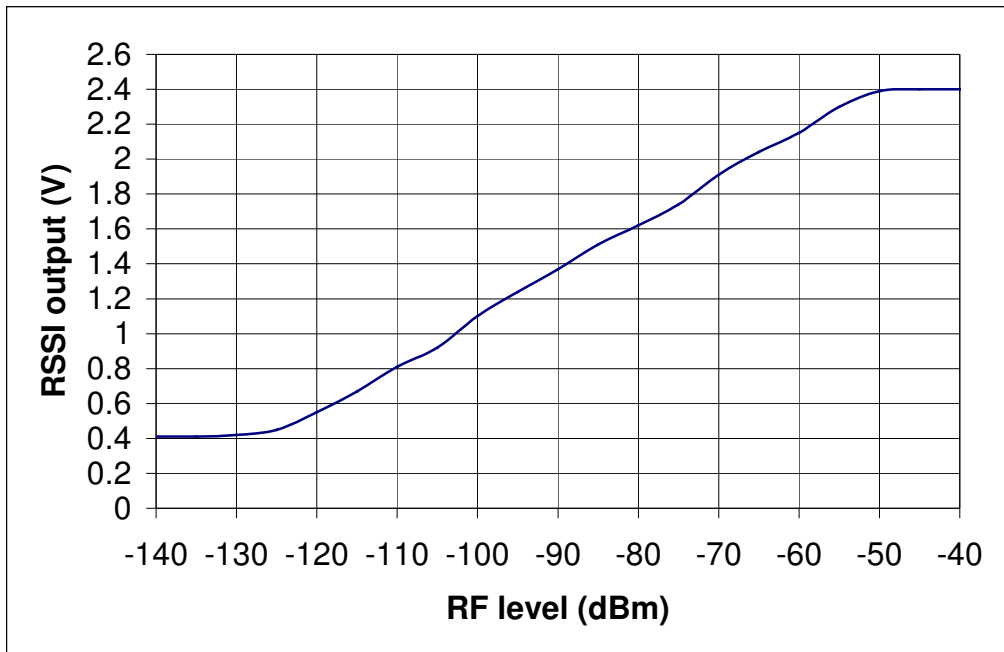

Figure 6: typical RSSI level with respect to received RF level at LMR2 antenna pin

Antenna requirements

Three types of integral antenna are recommended and approved for use with the module:

- A) **Whip** This is a wire, rod ,PCB track or combination connected directly to RF pin of the module. Optimum total length is 16.4cm (1/4 wave @ 433MHz). Keep the open circuit (hot) end well away from metal components to prevent serious de-tuning. Whips are ground plane sensitive and will benefit from internal 1/4 wave earthed radial(s) if the product is small and plastic cased
- B) **Helical** Wire coil, connected directly to RF pin, open circuit at other end. This antenna is very efficient given it's small size (20mm x 4mm dia.). The helical is a high Q antenna, trim the wire length or expand the coil for optimum results. The helical de-tunes badly with proximity to other conductive objects.
- C) **Loop** A loop of PCB track tuned by a fixed or variable capacitor to ground at the 'hot' end and fed from RF pin at a point 20% from the ground end. Loops have high immunity to proximity de-tuning.

Feature	A	B	C
	<i>whip</i>	<i>helical</i>	<i>loop</i>
Ultimate performance	***	**	*
Easy of design set-up	***	**	*
Size	*	***	**
Immunity proximity effects	*	**	***
Range open ground to similar antenna	500m	200	100

The antenna choice and position directly controls the system range. Keep it clear of other metal in the system, particularly the 'hot' end. The best position by far, is sticking out the top of the product. This is often not desirable for practical/ergonomic reasons thus a compromise may need to be reached. If an internal antenna must be used, try to keep it away from other metal components, particularly large ones like transformers, batteries and PCB tracks/earth plane. The space around the antenna is as important as the antenna itself.

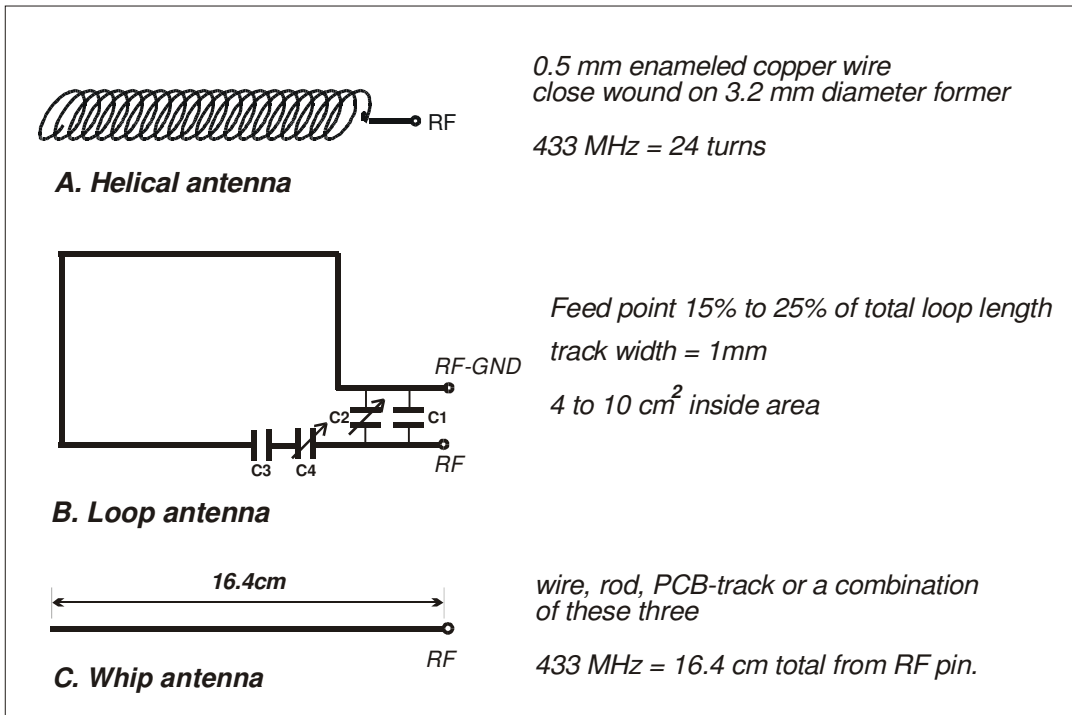

Figure 7: Antenna types

Ordering Information:

Part No.	Description	Frequency band (MHz)	RF power (mW)	Channel spacing (kHz)	Data rate (kbps)
LMT2-433-5	Transmitter	433.875-434.650	10	25	5
LMR2-433-5	Receiver	433.875-434.650		25	5
LMT2-458-5	Transmitter	458.525 - 459.1	100	25	5
LMR2-458-5	Receiver	458.525 - 459.1		25	5
LMT2-433-5-12k5	Transmitter	433.875-434.650	10	12.5	5
LMR2-433-5-12k5	Receiver	433.875-434.650		12.5	5
LMT2-458-5-12k5	Transmitter	458.525 - 459.1	100	12.5	5
LMR2-458-5-12k5	Receiver	458.525 - 459.1		12.5	5
LMT2-433-10	Transmitter	433.875-434.650	10	25	10
LMR2-433-10	Receiver	433.875-434.650		25	10
LMT2-458-10	Transmitter	458.525 - 459.1	100	25	10
LMR2-458-10	Receiver	458.525 - 459.1		25	10

Note: Also available on the other UHF band frequencies subject to SAW filter availability. e.g. 315, 419, 429, 448, 465MHz etc.

Radiometrix Ltd
Hartcran House
231 Kenton Lane
Harrow, Middlesex
HA3 8RP
ENGLAND
Tel: +44 (0) 20 8909 9595
Fax: +44 (0) 20 8909 2233
sales@radiometrix.com
www.radiometrix.com

Copyright notice

This product data sheet is the original work and copyrighted property of Radiometrix Ltd. Reproduction in whole or in part must give clear acknowledgement to the copyright owner.

Limitation of liability

The information furnished by Radiometrix Ltd is believed to be accurate and reliable. Radiometrix Ltd reserves the right to make changes or improvements in the design, specification or manufacture of its subassembly products without notice. Radiometrix Ltd does not assume any liability arising from the application or use of any product or circuit described herein, nor for any infringements of patents or other rights of third parties which may result from the use of its products. This data sheet neither states nor implies warranty of any kind, including fitness for any particular application. These radio devices may be subject to radio interference and may not function as intended if interference is present. We do NOT recommend their use for life critical applications.

The Intrastat commodity code for all our modules is: 8542 6000.

R&TTE Directive

After 7 April 2001 the manufacturer can only place finished product on the market under the provisions of the R&TTE Directive. Equipment within the scope of the R&TTE Directive may demonstrate compliance to the essential requirements specified in Article 3 of the Directive, as appropriate to the particular equipment.

Further details are available on The Office of Communications (Ofcom) web site:

<http://www.ofcom.org.uk/radiocomms/ifi/>

Information Requests

Ofcom

Riverside House

2a Southwark Bridge Road

London SE1 9HA

Tel: +44 (0)845 456 3000 or 020 7981 3040

Fax: +44 (0)20 7783 4033

information.requests@ofcom.org.uk

European Radiocommunications Office (ERO)

Peblingehus

Nansensgade 19

DK 1366 Copenhagen

Tel. +45 33896300

Fax +45 33896330

ero@ero.dk

www.ero.dk
