

UHF FM Code-Hopping Receiver Module

KRX2 is a small PCB mounting UHF integrated receiver-decoder module that is ready-to-use with our UHF FM code-hopping transmitters for secure wireless remote control and keyless security systems.



Figure 1: KRX2-433

Features

- Operates on 433.92MHz European licence exempt frequency
- All decoding and interfacing performed by the module
- Four outputs facilitate 15 different control codes for each transmitter
- Output interface to logic, microcontrollers or directly drive LEDs
- Learn input - remembers up to 16 different transmitters
- Remembers transmitters when power removed
- Output indication of Learn function
- Output indication of low supply voltage at a Transmitter
- Momentary (output follows input) or 10ms pulse output modes
- High performance receiver section may be used on its own
- DIL module form factor
- 5VDC supply

Applications

- RF interface for Security and Alarm systems
- Status reporting and monitoring secure systems
- Industrial controls
- HVAC controls
- Door entry systems
- Simple On/Off switching

General Description

KRX2 is a complete UHF FM receiver and rolling code decoder/interface in a compact form factor that may be placed directly into an end application with no special considerations. It is designed for use with our KTX2 module and KFX2 “Key-fob” products.

In addition to its use as a ready-built code-hopping decoder, all the usual receiver connections are made available so that the receiver may be used for additional applications of the designer’s choosing.

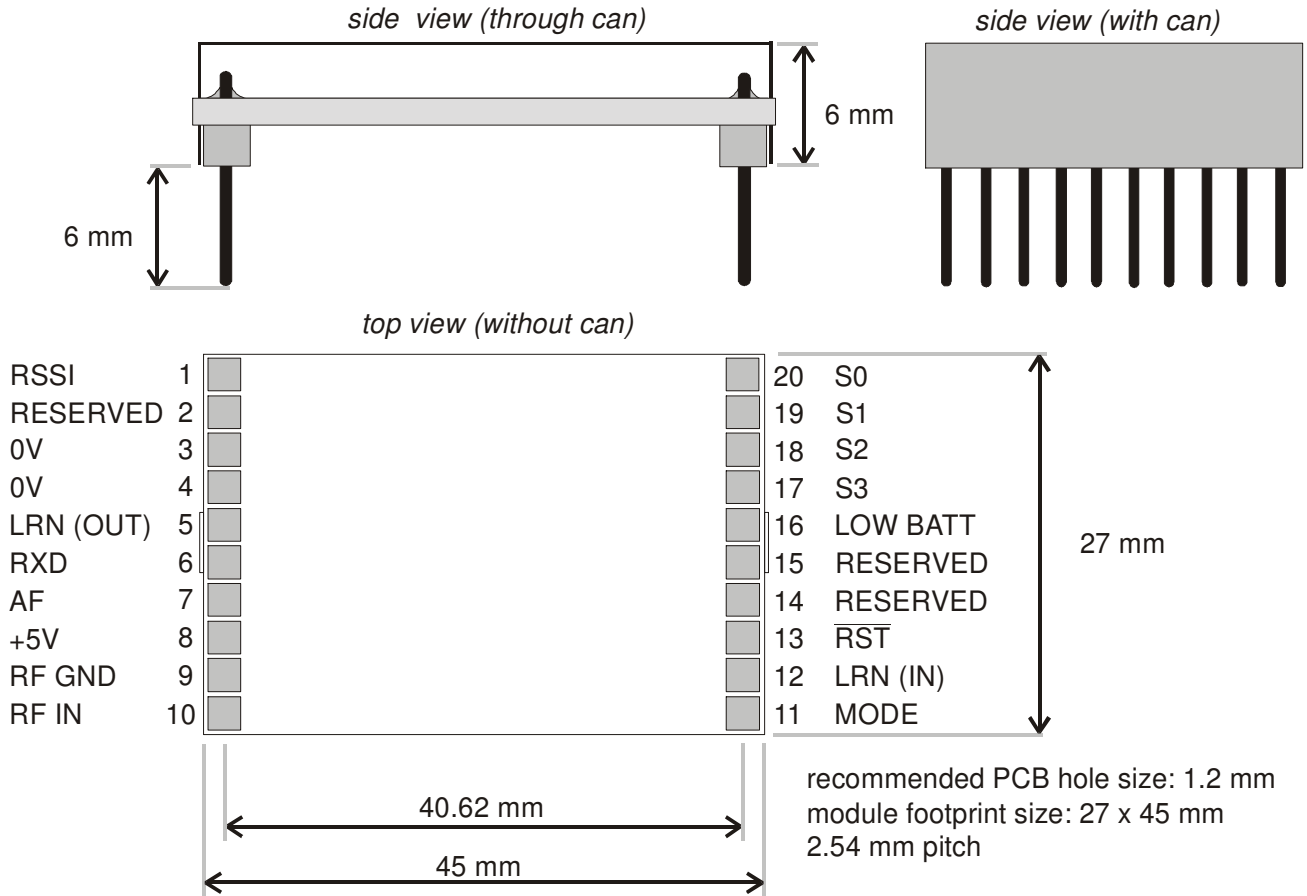

Figure 2: KRX2 Dimensions and pin-out

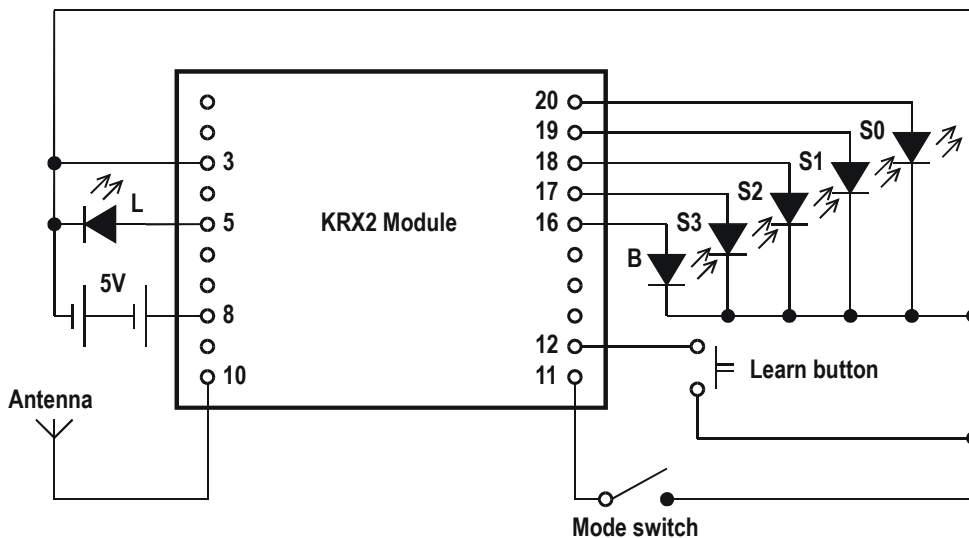

Figure 3: example connection diagram

Pin description

| Pin | Name | Function |
|-----|-----------|---|
| 1 | RSSI | Analogue output of received signal strength indication with 60dB range. See page 5 for typical characteristics. |
| 2 | RESERVED | Do not connect anything to this pin |
| 3 | 0V | DC supply 0V. Internally connected to pins 4 & 9 and module screen. |
| 4 | 0V | DC supply 0V. Internally connected to pins 3 & 9 and module screen. |
| 5 | LRN (OUT) | Digital indication of Learn function - see below for operational description. |
| 6 | RXD | Digital output from the internal data slicer, i.e. a squared version of the signal on pin 7 (AF). It may be used to drive external decoders. |
| 7 | AF | Buffered and filtered analogue output from the FM demodulator. Standing DC bias 2V approx. External load should be >10kΩ // <100pF. |
| 8 | +5V | +5V regulated power supply (4.5 - 5.25V) |
| 9 | RF GND | RF ground pin, internally connected to the module screen and pins 3 & 4 (0V). This pin should be connected to the RF return path (coax braid, main PCB ground plane etc.) |
| 10 | RF IN | 50Ω input from the antenna, DC isolated. |
| 11 | MODE | Digital input, normally high – high=10ms monostable output, low=momentary – see below for further description. |
| 12 | LRN (IN) | Digital input, normally high – taken low for learning transmitters or clearing decoder NV memory – see below for detailed description. |
| 13 | /RST | Resets Decoder when taken low. NV memory and receiver are unaffected. |
| 14 | RESERVED | Do not connect anything to this pin. |
| 15 | RESERVED | Do not connect anything to this pin. |
| 16 | LOW BATT | Digital output – indicates that the supply voltage at the transmitter of the current message has fallen below approx. 3.8V. |
| 17 | S3 | Digital output – function code of the current message |
| 18 | S2 | Digital output – function code of the current message |
| 19 | S1 | Digital output – function code of the current message |
| 20 | S0 | Digital output – function code of the current message |

Using KRX2

A simple connection diagram for experimental purposes is shown in Figure 3.

The Mode switch is connected between MODE and 0V and the Learn button is connected between LRN (IN) and 0V. The antenna can be just a few centimetres of wire, for test purposes. Refer to *antenna requirements* at the end of this datasheet for operational recommendations. The 5V shown would normally be supplied by a regulated low-noise PSU. Remaining digital outputs are all connected to LEDs to show the operation of the module.

CAUTION!

Take care that the supply **never** exceeds 5.5V, even momentarily: if this happens the module may be permanently damaged.

Learning a transmitter

The Learn button is pressed momentarily (<1s) and a 5-second (approx.) window follows, during which Learn LED “L” is lit and a message received from a Radiometrix code-hopped transmitter during this period is used to Learn that transmitter into the KRX2 memory. The function code used to activate the transmitter during learning is also stored in memory and when the same function code is used again from that transmitter during normal operation the Learn LED lights to indicate this. Note: if a transmitter has already been stored it is simply re-learned (with the function code updated if this is different). Upon learning a transmitter the Learn LED flashes several times to indicate success.

Activating outputs

Once a transmitter has been learned its transmissions will be acted upon, i.e. the function code contained within the transmission is fed to the KRX2 outputs S0 – S3. Either a 10ms single-shot output or a longer momentary output can be used according to the MODE selected. In the circuit shown in Fig. 3, closing the switch will select “momentary” mode.

In 10ms “single-shot” mode the output(s) are activated for only 10ms (nominal) per message received. This means that regardless of whether someone “holds down the button” at the sending device, the KRX2 output will only be a single 10ms pulse. However, if the function code is added to by the sender (e.g. another function code button is pressed in addition to the first) then both the original output and the new output will provide a 10ms pulse. This is because a new function code = new message.

In Momentary mode the output is activated for a short period (approx. 500ms) for reception of a single message. If the same message is received repeatedly the output status is refreshed during this period: in effect, the output is “held-on” whilst a user keeps the relevant function line enabled at the transmitter.

If the message was received from a transmitter being supplied less than approx. 3.8V the Low battery output (LED “B” in the circuit shown in Fig. 3) will be activated.

Clearing the memory

When the memory is full, no new transmitters can be learned. To clear the memory of *all* stored transmitters, the Learn button is pressed and held for more than approx. 5s. The Learn LED will go out and upon releasing the button it will flash once to indicate that the memory has been cleared. It is not possible to remove individual transmitters from the memory.

Code-hopped messages - technical brief

Transmission format is 1250bps (nominal rate) Manchester encoding. Although the function-code is only 4 bits, total message length is 67 bits. This includes a 28-bit serial number and a 32-bit encrypted hop-code. Note that the serial number and function code data is not encrypted. The correct status of the transmission is used to validate the data. This is achieved through use of the ever changing hop-code (changes for every new message) and by synchronising the KRX2 to the transmitter(s) in use. Put another way: KRX2 “Learns” individual unique transmitters, as required by the user.

The hop-code is encrypted using the serial number of the transmitter plus the manufacturer code (64-bit), which is kept secret and is not transmitted. The function-code (S0-S3) appears twice in the message and forms a part of the hop-code encryption process.

If KRX2 loses synchronisation with the transmitter (e.g. repeated transmitter activation whilst out of range) then the transmitter must be activated twice with valid and sequential hop-codes before KRX2 will allow the control to be processed. The hop-code is only valid if it is within a *forward* window of +32768 activations. This mechanism prevents “code-grabbers” from breaking the security of the system by recording and re-broadcasting old codes. Additionally, KRX2 allows up to 14 transmissions to occur whilst the transmitter is out of range before two valid sequential transmissions are required to use the system. In practice a user may not notice the latter, since human reaction to the unsuccessful attempt is simply to “press the button again”.

The level of redundancy and encryption in a message mean that, in simple terms, KRX2 will only output a function-code that has been received from a properly recognised and synchronised transmitter.

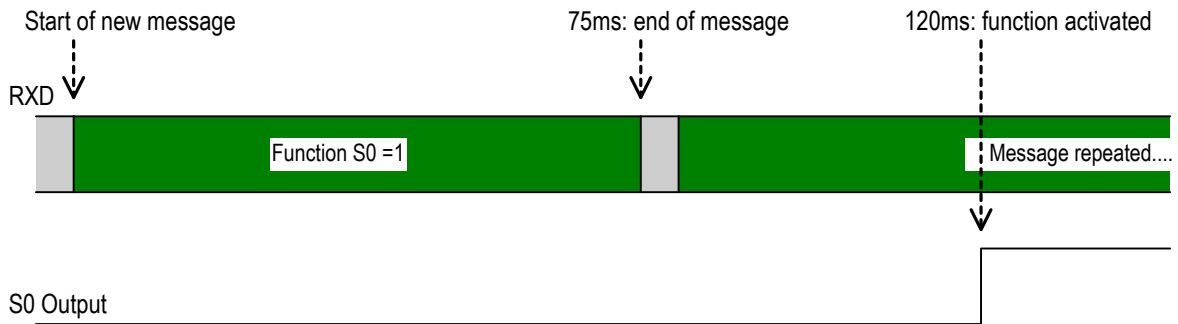

Figure 4: Timing diagram – showing action upon receiving a message with $S0 = 1$

Received Signal Strength Indication (RSSI)

The KRX2 module incorporates a wide range RSSI that measures the strength of an incoming signal over a range of approximately 60dB. This allows assessment of link quality and available margin and is useful when performing range tests.

Please note that the actual RSSI voltage at any given RF input level varies somewhat between units. The RSSI facility is intended as a relative indicator only - it is not designed to be, or suitable as, an accurate and repeatable measure of absolute signal level or transmitter-receiver distance.

The output on pin 5 of the module has a standing DC bias in the region of 0.5V with no signal, rising to around 1V at maximum indication. The RSSI output source impedance is high ($\sim 100k\Omega$) and external loading should therefore be kept to a minimum.

To ensure a fast response the RSSI has limited internal decoupling of 1nF to ground. This may result in a small amount of ripple on the DC output at pin 5 of the module. If this is a problem further decoupling may be added at the expense of response speed, in the form of a capacitor from pin 5 to ground. For example, adding 10nF here will increase RSSI response time from 100 μ s to around 1ms. The value of this capacitor may be increased without limit.

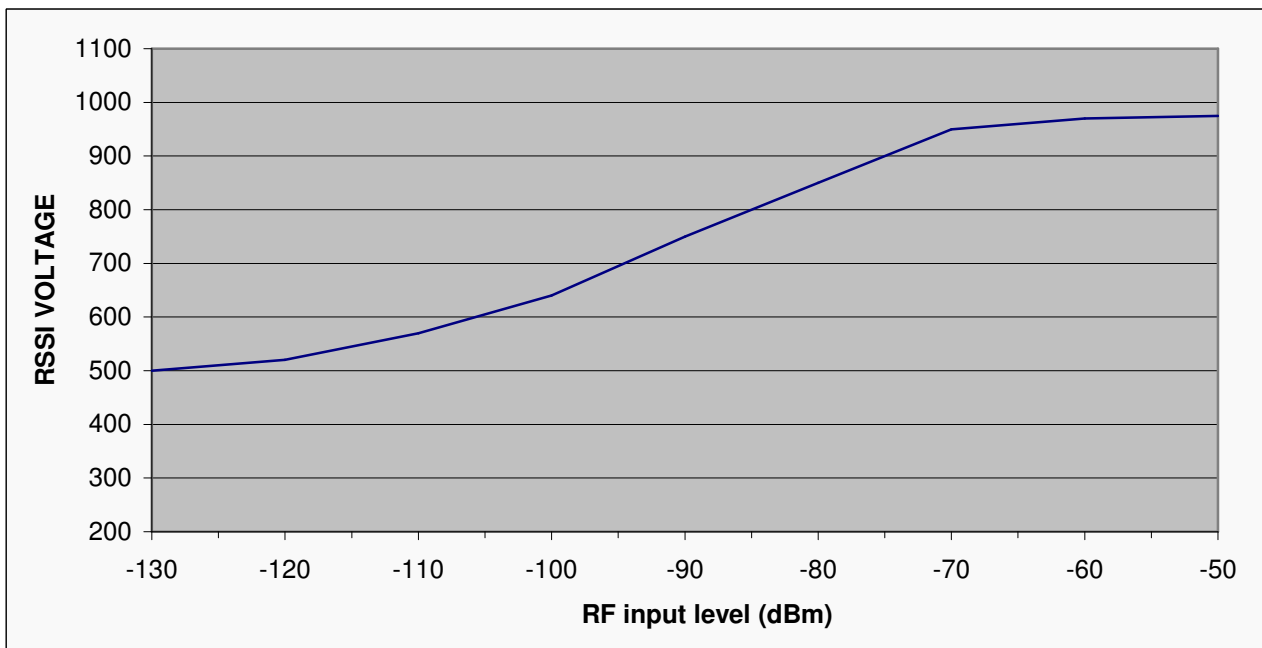

Figure 5: Typical RSSI response

Absolute maximum ratings

Survival Maximums:

Exceeding the values given below may cause permanent damage to the module.

| | |
|----------------------------|--------------------|
| Operating temperature - | -20°C to +70°C |
| Storage temperature | -40°C to +100°C |
| DC supply (pin 8) | -0.1V to +5.5V |
| RSSI, AF, RXD (pins 1,7,6) | -0.1V to +3V |
| RF IN (pin 1) | ±50V DC, +10dBm RF |
| Digital inputs/outputs | -0.1V to +5.5V |

Performance specifications: KRX2

(DC supply = 5.0V / temperature = 20 °C unless stated)

| | Pin | min. | typ. | max. | units | notes |
|-------------------------------------|---------|------|--------|------|-------------------|-------|
| DC supply | | | | | | |
| Supply voltage | 8 | 4.5 | 5.0 | 5.25 | V | 1 |
| Supply current | 8 | 15 | 18 | 22 | mA | 2 |
| RF/ IF | | | | | | |
| RF centre frequency | | | 433.92 | | MHz | |
| RF sensitivity for 12dB (S+S/N) | 10 | - | -114 | - | dBm | 3 |
| RSSI range | 1 | - | 60 | - | dB | |
| IF bandwidth | - | - | 180 | - | kHz | |
| Image rejection | - | 50 | 54 | - | dB | |
| IF rejection (10.7MHz) | - | 100 | - | - | dB | |
| LO leakage, conducted | - | - | -125 | -110 | dBm | |
| Baseband | | | | | | |
| AF level | 7 | 200 | 250 | 350 | mV _{P-P} | 3 |
| DC offset on AF out | 7 | 1.5 | 2 | 2.5 | V | 4 |
| Distortion on recovered AF | 7 | - | 1 | 5 | % | 4 |
| Load capacitance, AFout/RXD | 7,6 | - | - | 100 | pF | |
| DYNAMIC TIMING | | | | | | |
| Power up with signal present | | | | | | |
| Power up to valid RSSI | 1 | - | 0.5 | 1 | ms | |
| Power up to activated output | 5,16-20 | 150 | 200 | 250 | ms | 5 |
| Output pulse width (one-shot) | 5,16-20 | 9.5 | 10 | 11.5 | ms | |
| Output pulse width (momentary) | 5,16-20 | 470 | 500 | 570 | ms | |
| Clear memory input pulse | 12 | 5.4 | | | s | |

Notes:

- 1) A low noise supply is recommended – ripple <100mVp-p
- 2) Idle state with no RF signal present and no other inputs or outputs active.
- 3) For received signal with ±30kHz FM deviation.
- 4) Typical figures are for signal at centre frequency, max. figures are for ±50kHz offset.
- 5) Assuming that the message is from a transmitter that is already learned and hop-code synchronised to the KRX2.

Module mounting considerations

Good RF layout practice should be observed – in particular, any ground return required by the antenna or feed should be connected directly to the RF GND pin at the antenna end of the module, and not to the OV pin which is intended as a DC ground only. All connecting tracks should be kept as short as possible to avoid any problems with stray RF pickup.

If the connection between module and antenna does not form part of the antenna itself, it should be made using 50Ω microstrip line or coax or a combination of both. It is desirable (but not essential) to fill all unused PCB area around the module with ground plane.

The module may be potted if required in a viscous compound which cannot enter the screen can.

Warning: *DO NOT wash the module. It is not hermetically sealed.*

Variants and ordering information

The KRX2 is available as a standard version:

KRX2-433

The standard frequency is 433.92MHz, for other frequency variants, please contact sales department.

For all other variants please contact Sales department.

To make a complete code-hopping system:

Suitable Transmitter module to use with KRX2:

KTX2

Suitable ready-built Keyfob product:

KFX2

Antenna requirements

Three types of integral antenna are recommended and approved for use with the module:

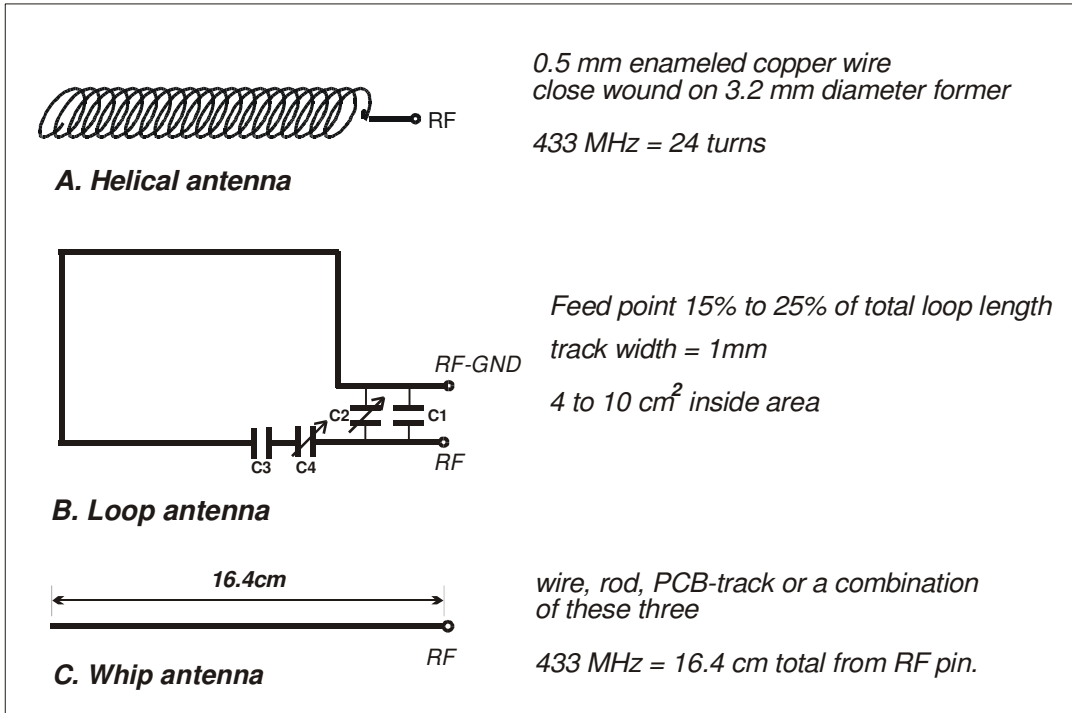

Figure 6: Antenna configuration

| Feature | A | B | C |
|----------------------------------|----------------|-------------|-------------|
| | <i>helical</i> | <i>loop</i> | <i>whip</i> |
| Ultimate performance | ** | * | *** |
| Easy of design set-up | ** | * | *** |
| Size | *** | ** | * |
| Immunity proximity effects | ** | *** | * |
| Relative range (baseline = loop) | 2x loop | (loop) | 3x loop |

Antenna selection chart

- A) *Helical* Wire coil, connected directly to pin 10, open circuit at other end. This antenna is very efficient given it's small size (20mm x 4mm dia.). The helical is a high Q antenna, trim the wire length or expand the coil for optimum results. The helical de-tunes badly with proximity to other conductive objects.
- B) *Loop* A loop of PCB track tuned by a fixed or variable capacitor to ground at the 'hot' end and fed from pin 10 at a point 20% from the ground end. Loops have high immunity to proximity de-tuning.
- C) *Whip* This is a wire, rod, PCB track or combination connected directly to pin 10 of the module. Optimum total length is 15.5cm (1/4 wave @ 433MHz). Keep the open circuit (hot) end well away from metal components to prevent serious de-tuning. Whips are ground plane sensitive and will benefit from internal 1/4 wave earthed radial(s) if the product is small and plastic cased

The antenna choice and position directly controls the system range. Keep it clear of other metal in the system, particularly the 'hot' end. The best position by far, is sticking out the top of the product. This is often not desirable for practical/ergonomic reasons thus a compromise may need to be reached. If an internal antenna must be used try to keep it away from other metal components, particularly large ones like transformers, batteries and PCB tracks/earth plane. The space around the antenna is as important as the antenna itself

Radiometrix Ltd

**Hartcran House
231 Kenton Lane
Harrow, Middlesex
HA3 8RP
ENGLAND**

**Tel: +44 (0) 20 8909 9595
Fax: +44 (0) 20 8909 2233
sales@radiometrix.com
www.radiometrix.com**

Copyright notice

This product data sheet is the original work and copyrighted property of Radiometrix Ltd. Reproduction in whole or in part must give clear acknowledgement to the copyright owner.

Limitation of liability

The information furnished by Radiometrix Ltd is believed to be accurate and reliable. Radiometrix Ltd reserves the right to make changes or improvements in the design, specification or manufacture of its subassembly products without notice. Radiometrix Ltd does not assume any liability arising from the application or use of any product or circuit described herein, nor for any infringements of patents or other rights of third parties which may result from the use of its products. This data sheet neither states nor implies warranty of any kind, including fitness for any particular application. These radio devices may be subject to radio interference and may not function as intended if interference is present. We do NOT recommend their use for life critical applications.

The Intrastat commodity code for all our modules is: 8542 6000

R&TTE Directive

After 7 April 2001 the manufacturer can only place finished product on the market under the provisions of the R&TTE Directive. Equipment within the scope of the R&TTE Directive may demonstrate compliance to the essential requirements specified in Article 3 of the Directive, as appropriate to the particular equipment.

Further details are available on The Office of Communications (Ofcom) web site:

<http://www.ofcom.org.uk/>

Information Requests

Ofcom

Riverside House

2a Southwark Bridge Road

London SE1 9HA

Tel: +44 (0)300 123 3333 or 020 7981 3040

Fax: +44 (0)20 7981 3333

information.requests@ofcom.org.uk

European Communications Office (ECO)

Pebblinghus

Nansensgade 19

DK 1366 Copenhagen

Tel. +45 33896300

Fax +45 33896330

ero@ero.dk

www.ero.dk
