

HX1

Issue 2, 27 July 2012

VHF Narrow Band FM 300mW Transmitter

The special HX1 transmitter modules offer a 300mW RF output VHF data link in Radiometrix SIL standard pin-out and footprint. This makes the HX1 ideally suited to those low power applications where existing narrow band and wideband transmitters provide insufficient range. Together with the matching NRX1 or BiM1R receiver a one-way radio data link can be achieved over a distance up to 10km+ with suitable choice of data rate and antennas.



Figure 1: HX1-144.390-3

Features

- Standard frequencies: 144.390, 144.800 and 169.4125MHz
- Other frequencies from 120MHz to 180MHz
- Data rates up to 3kbps
- Usable range over 10km
- Fully screened
- Low power requirements

The HX1 is a narrow band radio transmitter module for use in long range data transfer applications at ranges up to 10kilometres. HX1 transmitter circuit is the BiM1T transmitter circuit in the TX1 pin-out with slightly enlarged dimension to accommodate extra Power Amplifier circuit to produce 300mW RF output and available for operation on 169.4-169.475MHz European licence exempt frequency band.

Applications

- Asset Tracking and Tracing
- Meter reading systems
- Automatic Position Reporting System (APRS)

Technical Summary

- Transmit power: 300mW (24.7dBm)
- Operating frequency: 144.390, 144.800 and 169.4125MHz
- Channel spacing: 25kHz
- Supply: 5V (regulated)
- Current consumption: 140mA nominal transmit
- Data bit rate: 3kbps or 10kbps max.
- Size: 43 x 15 x 5mm

Evaluation platforms: NBEK + SIL carrier

HX1 Single channel 300mW VHF transmitter

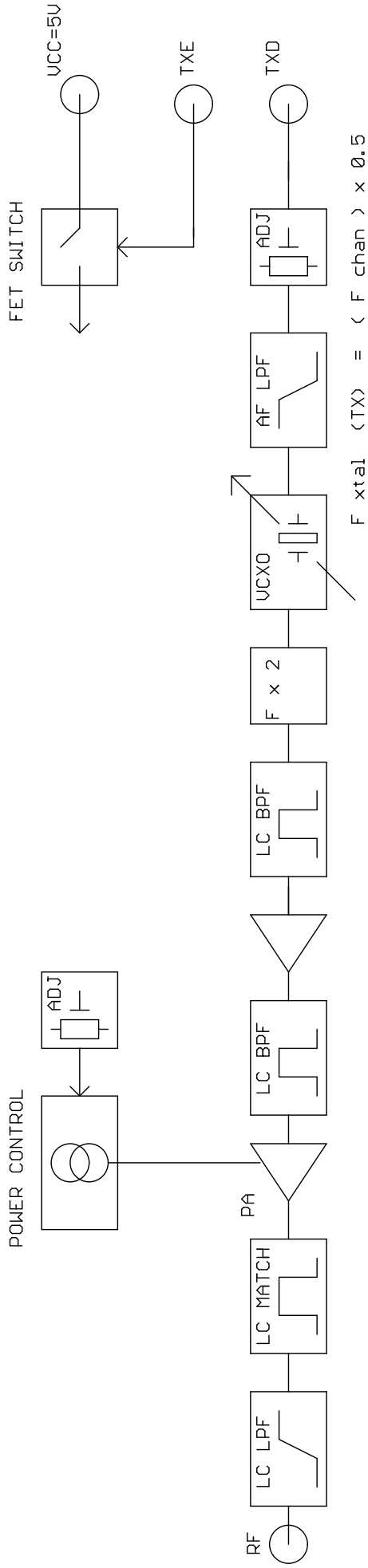

Figure 2: HX1 block diagram

Functional description

The HX1 transmitter consists of a frequency modulated Voltage Controlled Crystal Oscillator (VCXO) feeding a frequency doubler with two stage amplifier and RF filter. Final Power Amplifier stage is factory pre-set to appropriate band power level. Operation can be controlled by the EN (Enable) line, the transmitter achieving full RF output typically within 5ms of this line being pulled high. The RF output is filtered to ensure compliance with the appropriate radio regulations and fed to the 50Ω antenna pin.

User interface

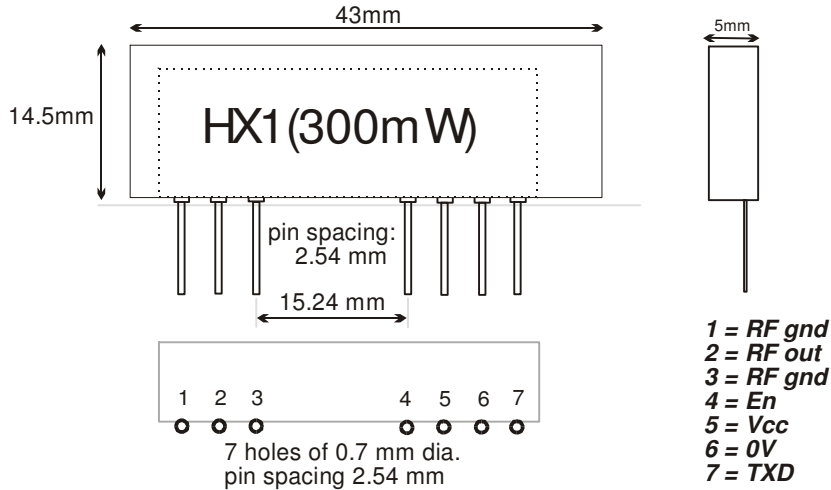

Figure 3: HX1 pin-out and dimension

Pin	Name	Function
1, 3	RFgnd	RF Ground
2	RF out	50Ω RF output to the antenna
4	EN	Pull high to enable Transmitter
5	VCC	5V regulated DC power supply
6	0V	Ground
7	TXD	DC coupled input for 5V CMOS logic. $R_{in} = 100k\Omega$

Note: Pinout and footprint as TX1. (but PCB is longer)

Absolute maximum ratings

Exceeding the values given below may cause permanent damage to the module.

Operating temperature -10°C to +60°C
Storage temperature -30°C to +70°C

Performance specifications:

(V_{cc} = 5V / temperature = 20°C unless stated)

	pin	min.	typ.	max.	units	notes
Supply						
Supply voltage	4	-	5	-	V	
TX Supply current	4	-	140mA	-	mA	
RF						
RF power output	2	+23.7	+24.7	+25.7	dBm	1
Spurious emissions	2	-	-40	-	dBm	
Adjacent channel TX power		-	-37	-	dBm	2
Frequency accuracy		-2.5	0	+2.5	kHz	3
FM deviation (peak)		±2.5	±3.0	±3.5	kHz	4
Antenna pin impedance	2	-	50	-	Ω	
RF centre frequency		-	169.4125	-	MHz	5
Channel spacing		-	25	-	kHz	
Number of channels		-	1	-		
Baseband						
Modulation bandwidth @ -3dB		0	-	5	kHz	6
TXD input level (logic low)	6	-	0	-	V	7
TXD input level (logic high)	6	-	5.0	-	V	7
Dynamic timing						
TX select to full RF		-	5	-	ms	

Notes:

1. Measured into 50Ω resistive load
2. For 1kbps Manchester encoded; the data bit rate is limited to 3kbps NRZ max. to meet adjacent channel power specification.
3. Total over full supply and temperature range
4. With 0V – 5.0V modulation input
5. Other VHF 120-180MHz by special order
6. 5V CMOS compatible
7. To achieve specified FM deviation

Applications information

Expected range

Predicting the range obtainable in any given situation is notoriously difficult since there are many factors involved. The main ones to consider are as follows:

- Type and location of antennas in use
- Type of terrain and degree of obstruction of the link path
- Sources of interference affecting the receiver
- “Dead” spots caused by signal reflections from nearby conductive objects
- Data rate and degree of filtering employed

The following are typical examples – but range tests should always be performed before assuming that a particular range can be achieved in a given situation:

Data rate	Tx antenna	Rx antenna	Environment	Range
1.2kbps	half-wave	half-wave	rural/open	10-15km
10kbps	half-wave	half-wave	rural/open	3-4km
10kbps	helical	half-wave	urban/obstructed	500m-1km
10kbps	helical	helical	in-building	100-200m

Note: The figure for 1.2kbps assumes that the receiver bandwidth has been suitably reduced by utilising an outboard sallen-key active audio filter and data slicer or similar arrangement.

Antennas

The choice and positioning of transmitter and receiver antennas is of the utmost importance and is the single most significant factor in determining system range. The following notes are intended to assist the user in choosing the most effective antenna type for any given application.

Integral antennas

These are relatively inefficient compared to the larger externally-mounted types and hence tend to be effective only over limited ranges. They do however result in physically compact equipment and for this reason are often preferred for portable applications. Particular care is required with this type of antenna to achieve optimum results and the following should be taken into account:

1. Nearby conducting objects such as a PCB or battery can cause detuning or screening of the antenna which severely reduces efficiency. Ideally the antenna should stick out from the top of the product and be entirely in the clear, however this is often not desirable for practical/ergonomic reasons and a compromise may need to be reached. If an internal antenna must be used try to keep it away from other metal components and pay particular attention to the “hot” end (i.e. the far end) as this is generally the most susceptible to detuning. The space around the antenna is as important as the antenna itself.
2. Microprocessors and microcontrollers tend to radiate significant amounts of radio frequency hash which can cause desensitisation of the receiver if its antenna is in close proximity. The problem becomes worse as logic speeds increase, because fast logic edges generate harmonics across the VHF range which are then radiated effectively by the PCB tracking. In extreme cases system range may be reduced by a factor of 5 or more. To minimise any adverse effects situate antenna and module as far as possible from any such circuitry and keep PCB track lengths to the minimum possible. A ground plane can be highly effective in cutting radiated interference and its use is strongly recommended.

The following types of integral antenna are in common use:

Quarter-wave whip. This consists simply of a piece of wire or rod connected to the module at one end. At 169MHz the total length should be 421mm from module pin to antenna tip including any interconnecting wire or tracking. Because of the length of this antenna it is almost always external to the product casing.

Helical. This is a more compact but slightly less effective antenna formed from a coil of wire. It is very efficient for its size, but because of its high Q it suffers badly from detuning caused by proximity to nearby conductive objects and needs to be carefully trimmed for best performance in a given situation. The size shown is about the maximum commonly used at 169MHz and appropriate scaling of length, diameter and number of turns can make individual designs much smaller.

Loop. A loop of PCB track having an inside area as large as possible (minimum about 5cm²), tuned and matched with 2 capacitors. Loops are relatively inefficient but have good immunity to proximity detuning, so may be preferred in shorter range applications where high component packing density is necessary.

Integral antenna summary:

Features	whip	helical	loop
Ultimate performance	***	**	*
Ease of design set-up	***	**	*
Size	*	***	**
Immunity to proximity effects	**	*	***

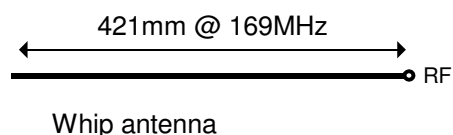

wire, rod, PCB track
or a combination of these
length(mm) = 71250 / freq(MHz)

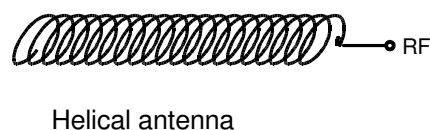

35-40 turns wire spring
length 120mm, dia 10mm
trim wire length or expand coil
for best results

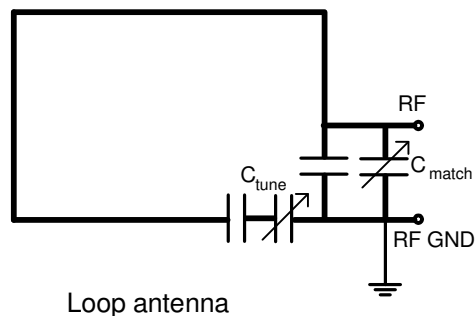

track width = 1mm
min. area 500mm²
capacitors may be variable or fixed
(values depend on loop dimensions)

Figure 4: integral antenna configurations

External antennas

These have several advantages if portability is not an issue, and are essential for long range links. External antennas can be optimised for individual circumstances and may be mounted in relatively good RF locations away from sources of interference, being connected to the equipment by coax feeder.

Helical. Of similar dimensions and performance to the integral type mentioned above, commercially-available helical antennas normally have the coil element protected by a plastic moulding or sleeve and incorporate a coax connector at one end (usually a straight or right-angle BNC type). These are compact and simple to use as they come pre-tuned for a given application, but are relatively inefficient and are best suited to shorter ranges.

Quarter-wave whip. Again similar to the integral type, the element usually consists of a stainless steel rod or a wire contained within a semi-flexible moulded plastic jacket. Various mounting options are available,

from a simple BNC connector to wall brackets, through-panel fixings and magnetic mounts for temporary attachment to steel surfaces.

A significant improvement in performance is obtainable if the whip is used in conjunction with a metal ground plane. For best results this should extend all round the base of the whip out to a radius of 300mm or more (under these conditions performance approaches that of a half-wave dipole) but even relatively small metal areas will produce a worthwhile improvement over the whip alone. The ground plane should be electrically connected to the coax outer at the base of the whip. Magnetic mounts are slightly different in that they rely on capacitance between the mount and the metal surface to achieve the same result.

A ground plane can also be simulated by using 3 or 4 quarter-wave radials equally spaced around the base of the whip, connected at their inner ends to the outer of the coax feed. A better match to a 50Ω coax feed can be achieved if the elements are angled downwards at approximately 30-40° to the horizontal.

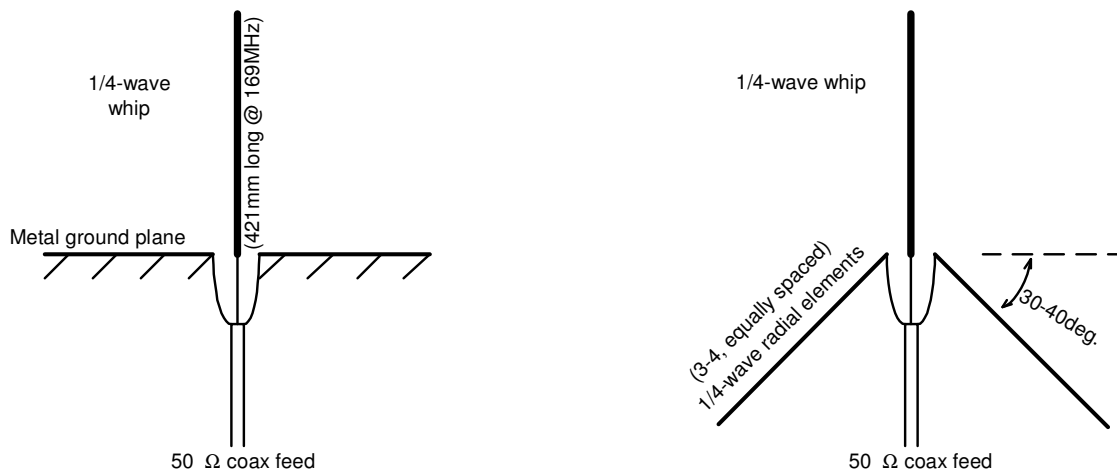

Fig.5: Quarter wave antenna / ground plane configurations

Half-wave. There are two main variants of this antenna, both of which are very effective and are recommended where long range and all-round coverage are required:

1. The half-wave dipole consists of two quarter-wave whips mounted in line vertically and fed in the centre with coaxial cable. The bottom whip takes the place of the ground plane described previously. A variant is available using a helical instead of a whip for the lower element, giving similar performance with reduced overall length. This antenna is suitable for mounting on walls etc. but for best results should be kept well clear of surrounding conductive objects and structures (ideally >1m separation).
2. The end-fed half wave is the same length as the dipole but consists of a single rod or whip fed at the bottom via a matching network. Mounting options are similar to those for the quarter-wave whip. A ground plane is sometimes used but is not essential. The end-fed arrangement is often preferred over the centre-fed dipole because it is easier to mount in the clear and above surrounding obstructions.

Yagi. This antenna consists of two or more elements mounted parallel to each other on a central boom. It is directional and exhibits gain but tends to be large and unwieldy – for these reasons the yagi is the ideal choice for links over fixed paths where maximum range is desired.

Module mounting considerations

The modules may be mounted vertically or bent horizontal to the motherboard.

Good RF layout practice should be observed. If the connection between module and antenna is more than about 20mm long use 50Ω microstrip line or coax or a combination of both. It is desirable (but not essential) to fill all unused PCB area around the module with ground plane.

Variants and ordering information

The HX1 transmitter is manufactured in the following variants as standard:

HX1-144.390-10	US APRS
HX1-144.800-10	EU APRS
HX1-169.4125-3	EU Meter Reading, Asset Tracing and Tracing

Other variants can be supplied to individual customer requirements at frequencies from 120MHz to 180MHz subject to minimum order quantity and lead-time.

Matching Receivers:

NRX1-xxx.xxx-10 (SIL footprint)
BiM1R-xxx.xxx-10 (DIL footprint)

Radiometrix Ltd

**Hartcran House
231 Kenton Lane
Harrow, Middlesex
HA3 8RP
ENGLAND**

Tel: +44 (0) 20 8909 9595

Fax: +44 (0) 20 8909 2233

sales@radiometrix.com

www.radiometrix.com

Copyright notice

This product data sheet is the original work and copyrighted property of Radiometrix Ltd. Reproduction in whole or in part must give clear acknowledgement to the copyright owner.

Limitation of liability

The information furnished by Radiometrix Ltd is believed to be accurate and reliable. Radiometrix Ltd reserves the right to make changes or improvements in the design, specification or manufacture of its subassembly products without notice. Radiometrix Ltd does not assume any liability arising from the application or use of any product or circuit described herein, nor for any infringements of patents or other rights of third parties which may result from the use of its products. This data sheet neither states nor implies warranty of any kind, including fitness for any particular application. These radio devices may be subject to radio interference and may not function as intended if interference is present. We do NOT recommend their use for life critical applications.

The Intrastat commodity code for all our modules is: 8542 6000

R&TTE Directive

After 7 April 2001 the manufacturer can only place finished product on the market under the provisions of the R&TTE Directive. Equipment within the scope of the R&TTE Directive may demonstrate compliance to the essential requirements specified in Article 3 of the Directive, as appropriate to the particular equipment.

Further details are available on The Office of Communications (Ofcom) web site:

<http://www.ofcom.org.uk/>

Information Requests

Ofcom

Riverside House

2a Southwark Bridge Road

London SE1 9HA

Tel: +44 (0)300 123 3333 or 020 7981 3040

Fax: +44 (0)20 7981 3333

information.requests@ofcom.org.uk

European Communications Office (ECO)

Peblingehus

Nansensgade 19

DK 1366 Copenhagen

Tel. +45 33896300

Fax +45 33896330

ero@ero.dk

www.ero.dk