

< HVIC >

# M81740FP

## HIGH VOLTAGE HALF BRIDGE DRIVER

### DESCRIPTION

M81740FP is high voltage Power MOSFET and IGBT gate driver for half bridge applications.

### FEATURES

- Floating Supply Voltage ..... 600v
- Output Current .....  $\pm 3.25A$  (Typ.)
- Two Input Type ..... IN/ $\overline{SD}$
- Internally Set Deadtime
- 3.3v And 5v Input Logic Compatible.
- Half Bridge Driver
- Undervoltage Lockout
- SOP-8 Package

### APPLICATIONS

MOSFET and IGBT gate driver for Lighting, refrigerator, air-conditioner, washing machine, inverter and general purpose.

### PIN CONFIGURATION (TOP VIEW)

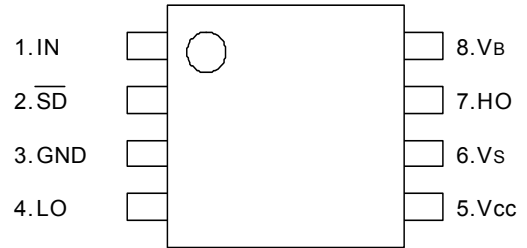

Outline: 8P2S  
(Pb Free)

### BLOCK DIAGRAM

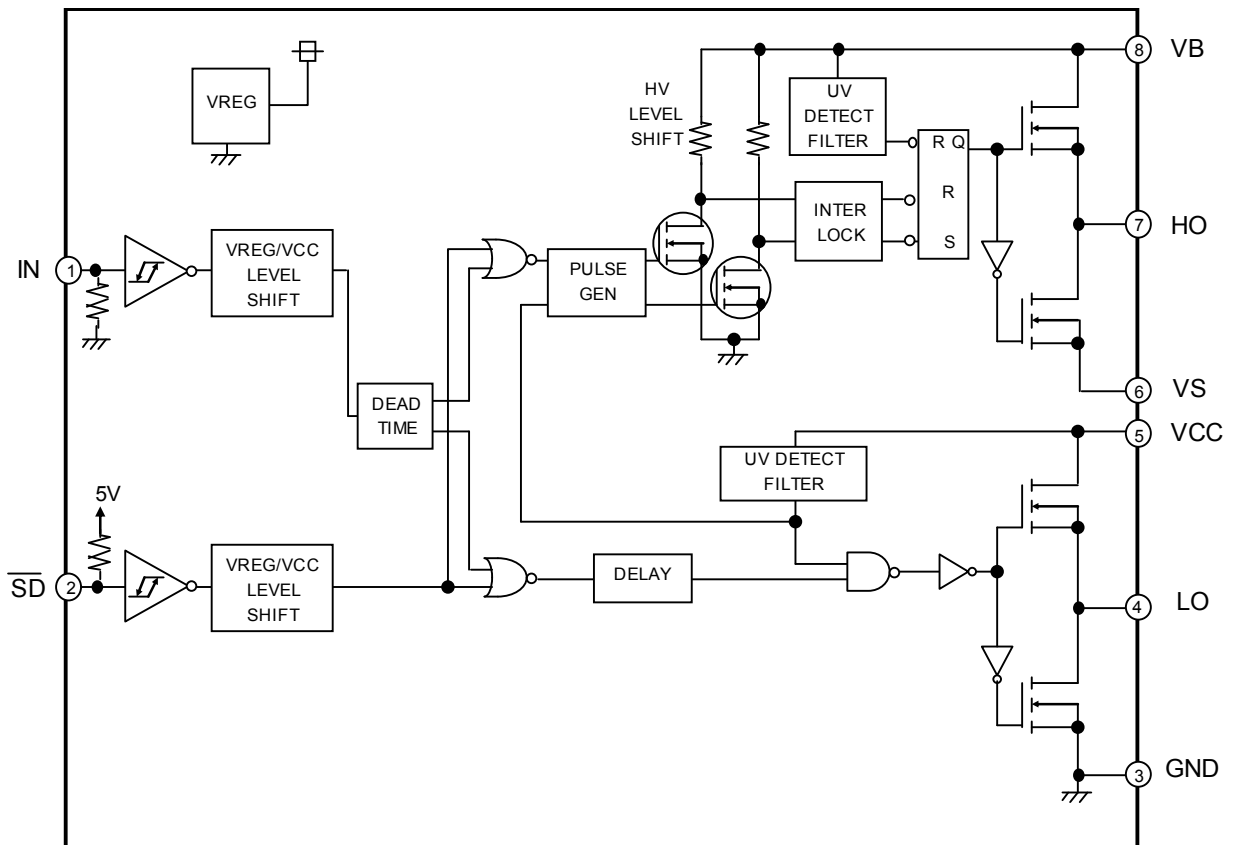

<HVIC>

# M81740FP

HIGH VOLTAGE HALF BRIDGE DRIVER

## TYPICAL CONNECTION ( General Purpose)

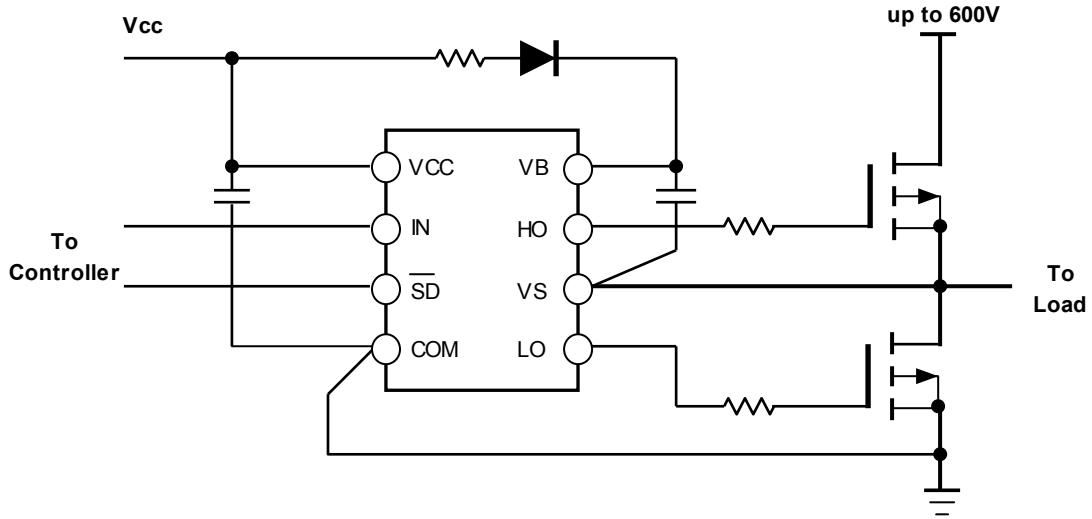

<HVIC>

# M81740FP

HIGH VOLTAGE HALF BRIDGE DRIVER

TYPICAL CONNECTION ( In Unipolar Modulation PWM Application)

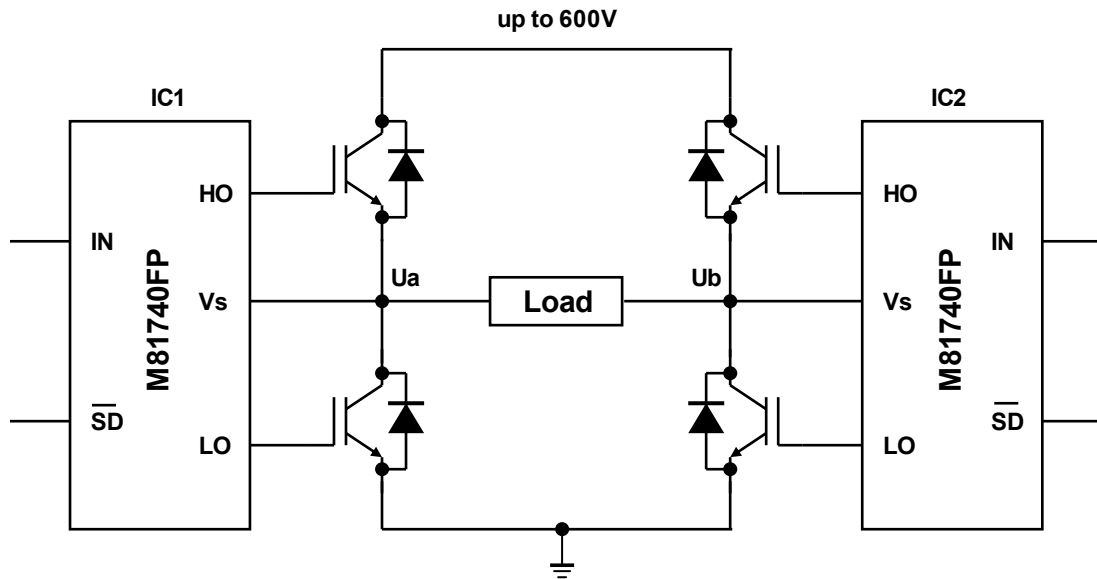

SEQUENCE (  $\overline{SD}$  is used as low side input terminal)

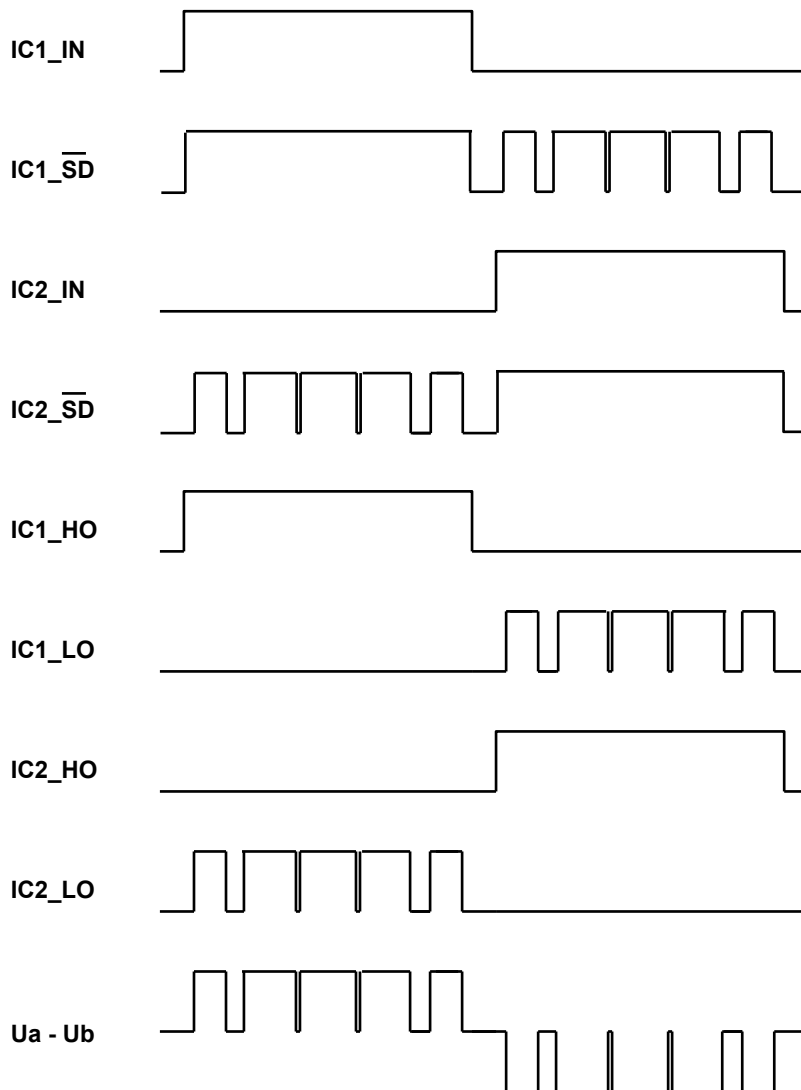

<HVIC>

# M81740FP

## HIGH VOLTAGE HALF BRIDGE DRIVER

### ABSOLUTE MAXIMUM RATINGS (Ta=25°C unless otherwise specified)

Symbol	Parameter	Test conditions	Ratings	Unit
V <sub>B</sub>	High Side Floating Supply Absolute Voltage		-0.3 ~ 624	V
V <sub>S</sub>	High Side Floating Supply Offset Voltage		V <sub>B</sub> -24 ~ V <sub>B</sub> +0.3	V
V <sub>BS</sub>	High Side Floating Supply Voltage	V <sub>BS</sub> =V <sub>B</sub> -V <sub>S</sub>	-0.3 ~ 24	V
V <sub>HO</sub>	High Side Output Voltage		V <sub>S</sub> -0.3 ~ V <sub>B</sub> +0.3	V
V <sub>CC</sub>	Low Side Fixed Supply Voltage		-0.3 ~ 24	V
V <sub>LO</sub>	Low Side Output Voltage		-0.3 ~ V <sub>CC</sub> +0.3	V
V <sub>IN</sub>	Logic Input Voltage (IN & $\overline{SD}$ )		-0.3 ~ V <sub>CC</sub> +0.3	V
dV <sub>S</sub> /dt	Allowable Offset Voltage Transient		±50	V/ns
P <sub>d</sub>	Package Power Dissipation	Ta= 25 °C ,On Board	0.6	W
K $\theta$	Linear Derating Factor	Ta> 25 °C ,On Board	4.8	mW/°C
R <sub>th(j-c)</sub>	Junction-Case Thermal Resistance		50	°C/W
T <sub>J</sub>	Junction Temperature		-40 ~ +150	°C
T <sub>opr</sub>	Operation Temperature		-40 ~ +125	°C
T <sub>stg</sub>	Storage Temperature		-50 ~ +150	°C
TL	Solder Heatproof	RoHS Correspondence	255:10s,max 260	°C

### RECOMMENDED OPERATING CONDITIONS

Symbol	Parameter	Test conditions	Limits			Unit
			Min.	Typ.	Max.	
V <sub>B</sub>	High Side Floating Supply Absolute Voltage		V <sub>S</sub> +10	—	V <sub>S</sub> +20	V
V <sub>S</sub>	High Side Floating Supply Offset Voltage	V <sub>B</sub> >10V	-5	—	500	V
V <sub>BS</sub>	High Side Floating Supply Voltage	V <sub>BS</sub> =V <sub>B</sub> -V <sub>S</sub>	10	—	20	V
V <sub>HO</sub>	High Side Output Voltage		V <sub>S</sub>	—	V <sub>B</sub>	V
V <sub>CC</sub>	Low Side Fixed Supply Voltage		10	—	20	V
V <sub>LO</sub>	Low Side Output Voltage		0	—	V <sub>CC</sub>	V
V <sub>IN</sub>	Logic Input Voltage (IN & $\overline{SD}$ )		0	—	5	V

\* For proper operation, the device should be used within the recommended conditions

### THERMAL DERATING FACTOR CHARACTERISTIC (MAXIMUM RATING)

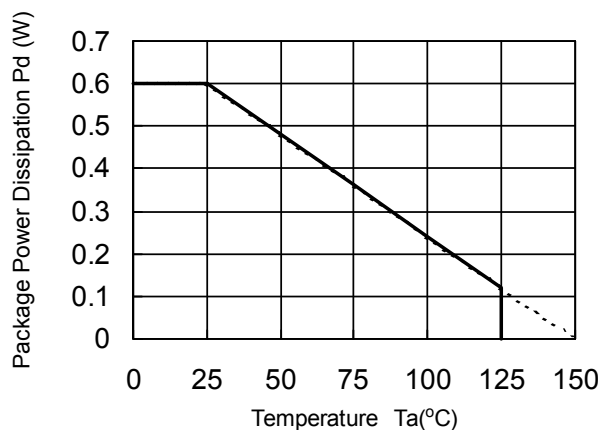

<HVIC>

# M81740FP

## HIGH VOLTAGE HALF BRIDGE DRIVER

### ELECTRICAL CHARACTERISTICS (Ta=25°C, V<sub>CC</sub>=V<sub>BS</sub>(=V<sub>B</sub>-V<sub>S</sub>)=15V, unless otherwise specified)

Symbol	Parameter	Test conditions	Limits			Unit
			Min.	Typ.*	Max.	
I <sub>FS</sub>	Floating Supply Leakage Current	V <sub>B</sub> = V <sub>S</sub> = 600V	—	—	1.0	μA
I <sub>BS</sub>	V <sub>BS</sub> Standby Current	I <sub>N</sub> = 0V or 5V	—	0.2	0.5	mA
I <sub>CC</sub>	V <sub>CC</sub> Standby Current	I <sub>N</sub> = 0V or 5V	0.2	0.6	1.0	mA
V <sub>OH</sub>	High Level Output Voltage	I <sub>O</sub> = 0mA, LO, HO	13.8	14.4	—	V
V <sub>OL</sub>	Low Level Output Voltage	I <sub>O</sub> = 20mA, LO, HO	—	—	0.2	V
V <sub>IH(IN)</sub>	High Level Input Threshold Voltage (V <sub>IN</sub> )		—	2.2	2.7	V
V <sub>IL(IN)</sub>	Low Level Input Threshold Voltage (V <sub>IN</sub> )		0.8	1.6	—	V
V <sub>IH(SD)</sub>	High Level Input Threshold Voltage (V <sub>SD</sub> )		—	2.2	2.7	V
V <sub>IL(SD)</sub>	Low Level Input Threshold Voltage (V <sub>SD</sub> )		0.8	1.6	—	V
I <sub>IH</sub>	High Level Input Bias Current	V <sub>IN</sub> = 5V, V <sub>SD</sub> =0V	—	25	60	μA
I <sub>IL</sub>	Low Level Input Bias Current	V <sub>IN</sub> = 0V, V <sub>SD</sub> =5V	—	—	5	μA
V <sub>BSuvr</sub>	V <sub>BS</sub> Supply UV Reset Voltage		7.0	8.4	9.8	V
V <sub>BSuvh</sub>	V <sub>BS</sub> Supply UV Hysteresis Voltage		0.3	0.5	—	V
t <sub>VBSuv</sub>	V <sub>BS</sub> Supply UV Filter Time		—	7.5	—	μs
V <sub>CCuvr</sub>	V <sub>CC</sub> Supply UV Reset Voltage		7.0	8.4	9.8	V
V <sub>CCuvh</sub>	V <sub>CC</sub> Supply UV Hysteresis Voltage		0.3	0.5	—	V
t <sub>VCCuv</sub>	V <sub>CC</sub> Supply UV Filter Time		—	7.5	—	μs
I <sub>OH</sub>	Output High Level Short Circuit Pulsed Current	V <sub>O</sub> = 0V, PW < 10μs	2.3	3.25	—	A
I <sub>OL</sub>	Output Low Level Short Circuit Pulsed Current	V <sub>O</sub> = 15V, PW < 10μs	2.3	3.25	—	A
t <sub>dLH</sub>	Turn-On Propagation Delay	CL = 1000pF between HO-V <sub>S</sub> , LO-GND V <sub>IN</sub> = 0 ~ 5V	—	—	900	ns
t <sub>dHL</sub>	Turn-Off Propagation Delay	CL = 1000pF between HO-V <sub>S</sub> , LO-GND V <sub>IN</sub> = 0 ~ 5V	—	—	400	ns
t <sub>SD</sub>	Shut Down Propagation Delay		—	—	270	ns
Δt <sub>dLH</sub>	Turn-On Propagation Delay Matching	t <sub>dLH</sub> (HO)-t <sub>dLH</sub> (LO)	—	0	90	ns
Δt <sub>dHL</sub>	Turn-Off Propagation Delay Matching	t <sub>dHL</sub> (HO)-t <sub>dHL</sub> (LO)	—	0	40	ns
t <sub>rH</sub>	High Side Turn-On Rise Time	CL = 1000pF between HO-V <sub>S</sub>	—	—	60	ns
t <sub>fH</sub>	High Side Turn-Off Fall Time	CL = 1000pF between HO-V <sub>S</sub>	—	—	35	ns
t <sub>rL</sub>	Low Side Turn-On Rise Time	CL = 1000pF between LO-GND	—	—	60	ns
t <sub>fL</sub>	Low Side Turn-Off Fall Time	CL = 1000pF between LO-GND	—	—	35	ns
t <sub>DEAD</sub>	Dead Time LO Turn-Off to HO Turn-On & HO Turn-Off to LO Turn-On	CL = 1000pF between HO-V <sub>S</sub> , LO-GND V <sub>IN</sub> = 0 ~ 5V	280	400	520	ns
Δt <sub>DEAD</sub>	Dead Time Matching	t <sub>DEAD</sub> (LO-HO)-t <sub>DEAD</sub> (HO-LO)	—	0	50	ns

\* Typ. is not specified.

### INPUT/OUTPUT TIMING DIAGRAM

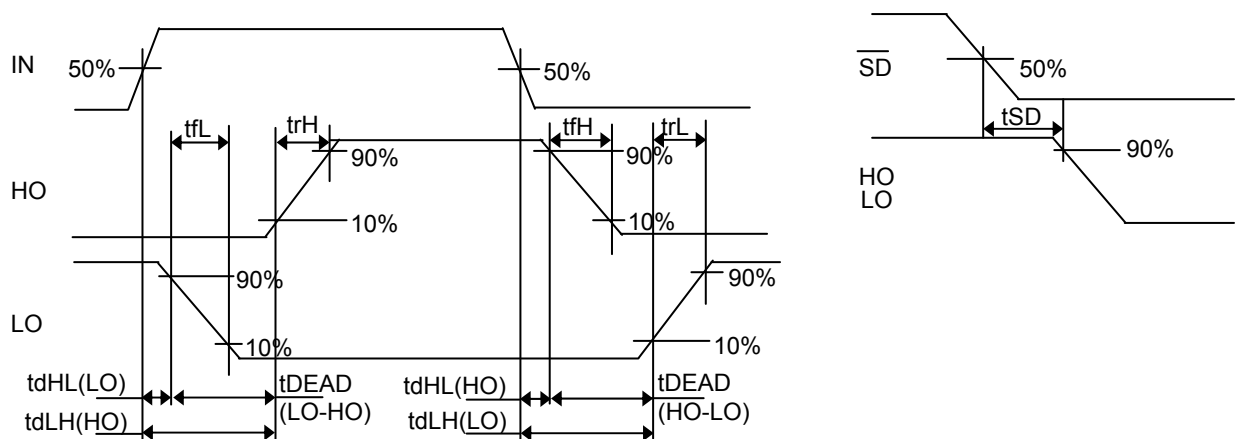

FUNCTION TIMING DIAGRAM 1

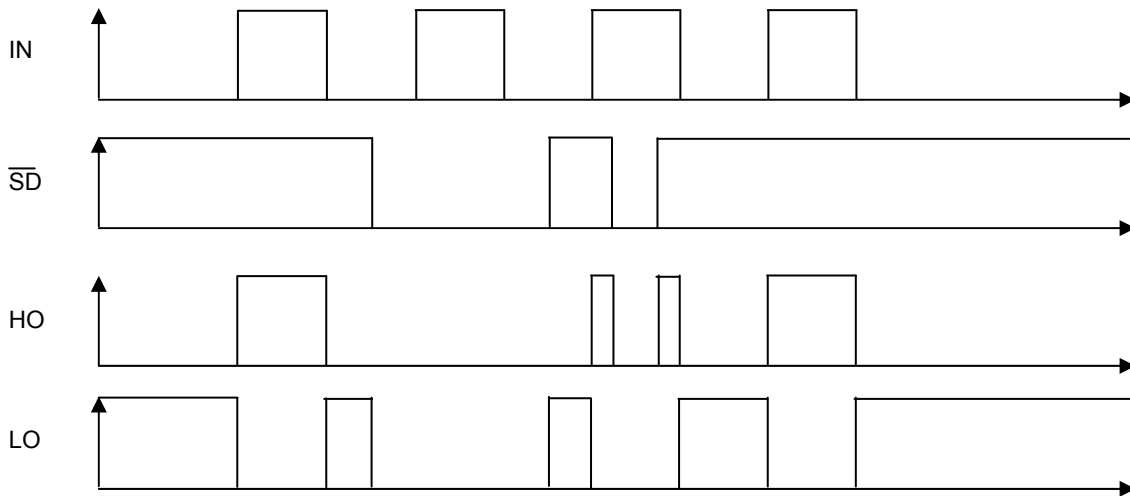

FUNCTION TIMING DIAGRAM 2

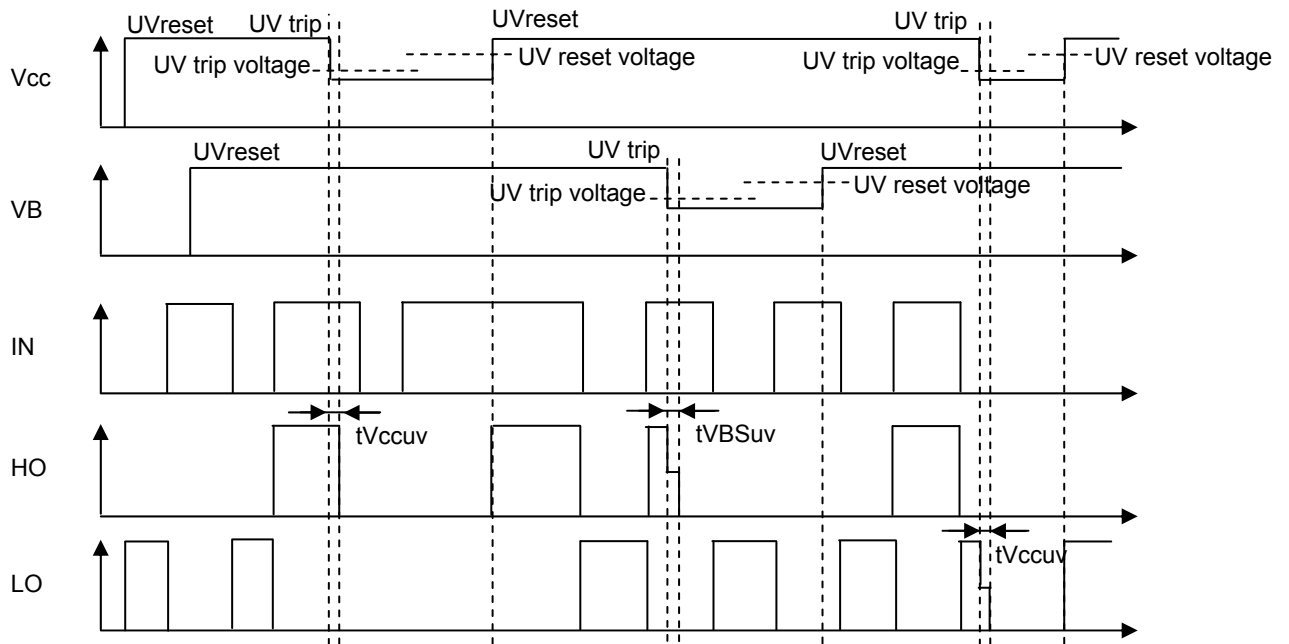

1. HO has positive logic with reference to IN. LO has negative logic with reference to IN.
2. Output signal (HO) is triggered by the edge of input signal.

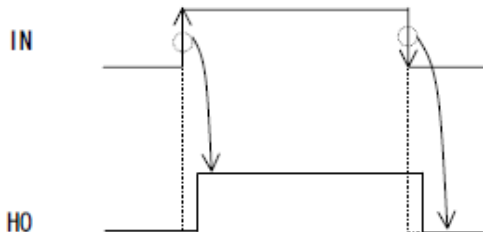

### 3. Logic During UV( $V_{CC}$ , $V_{BS}$ ) Error

Error Signal	HO	LO
UV error ( $V_{CC}$ )	HO is locked at "L" level as long as UV error for $V_{CC}$ is detected. After $V_{CC}$ exceeds $V_{CC}$ UV reset level, the lock for HO is removed and responds to IN signal. ( $V_{CC} > V_{BS}$ )	LO is locked at "L" level as long as UV error for $V_{CC}$ is detected. After $V_{CC}$ exceeds $V_{CC}$ UV reset level, the lock for LO is removed and responds to IN signal.
UV error ( $V_{BS}$ )	HO is locked at "L" level as long as UV error for $V_{BS}$ is detected. After $V_{BS}$ UV reset level, the lock for HO is removed following an "L" state of the IN signal, and then HO responds to the input.	LO is independent of $V_{BS}$ to respond to IN.

\*IF UV error for  $V_{CC}$  is detected when HO is in "H" level and the falling speed of  $V_{CC}$  is exceeds  $0.03V/\mu s$ , the off signal for HO might not be transmitted from low side to high side and then HO stays "H".

### 4. Supply start up sequence

Please start up  $V_{CC}$  supply and  $V_{BS}$  supply in that order, and, please shut down  $V_{BS}$  supply and  $V_{CC}$  supply in that order. Please start up  $V_{CC}$  supply and  $V_{BS}$  supply with gentle slope. If you start up supply with sharp slope, there is some possibility that HO or LO outputs "H" for a moment.

If  $V_{CC}$  supply is less than 10V(outside of RECOMMENDED OPERATING CONDITIONS), there is some possibility that output does not change in response to input. Please evaluate carefully about supply start up or restart after shut down in your application systems.

<HVIC>

# M81740FP

HIGH VOLTAGE HALF BRIDGE DRIVER

## PACKAGE OUTLINE

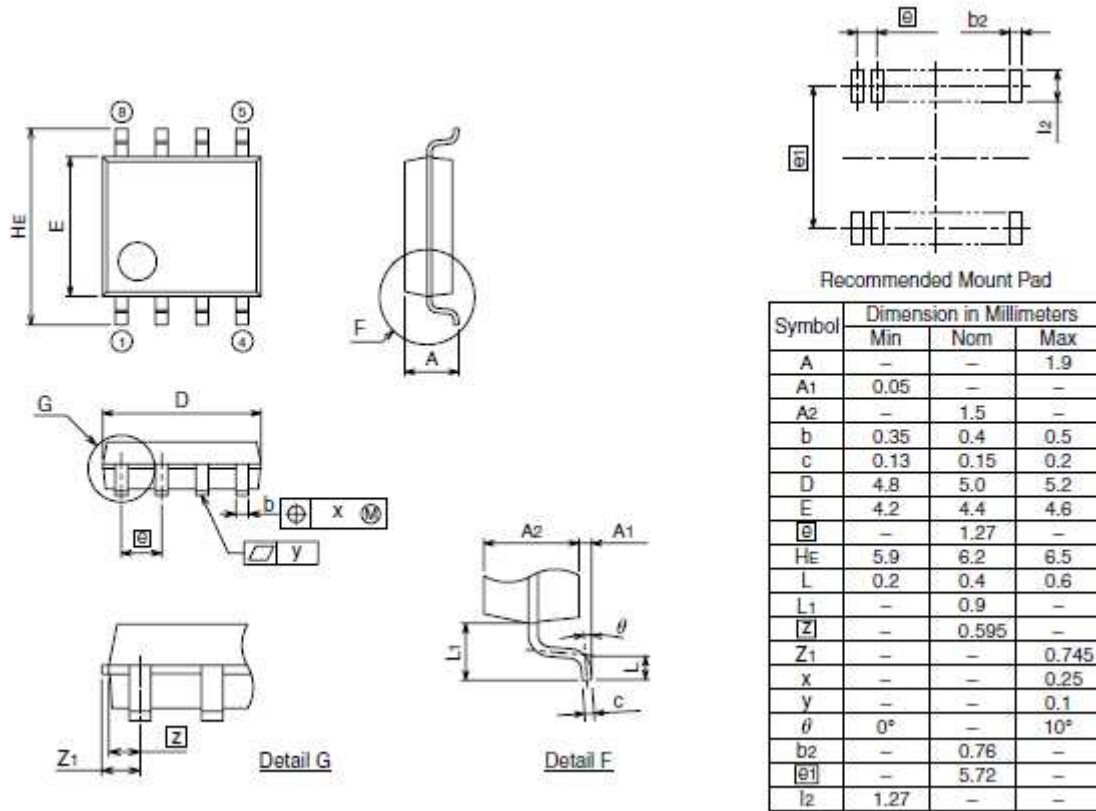

## Main Revision for this Edition

No.	Date	Revision	
		Pages	Points
A	2012.01.26	-	New
B	2012.04.10	-	“PRELIMINARY” was deleted. “Notice: This is not a final specification. Some parametric limits are subject to change.” was deleted.
		4	“Storage Temperature” was changed to “-50 ~ +150 °C”.
		5	Min. and Max. Limits of tDEAD was added.

**Keep safety first in your circuit designs!**

Mitsubishi Electric Corporation puts the maximum effort into making semiconductor products better and more reliable, but there is always the possibility that trouble may occur with them. Trouble with semiconductors may lead to personal injury, fire or property damage. Remember to give due consideration to safety when making your circuit designs, with appropriate measures such as (i) placement of substitutive, auxiliary circuits, (ii) use of non-flammable material or (iii) prevention against any malfunction or mishap.

**Notes regarding these materials**

- These materials are intended as a reference to assist our customers in the selection of the Mitsubishi semiconductor product best suited to the customer's application; they do not convey any license under any intellectual property rights, or any other rights, belonging to Mitsubishi Electric Corporation or a third party.
- Mitsubishi Electric Corporation assumes no responsibility for any damage, or infringement of any third-party's rights, originating in the use of any product data, diagrams, charts, programs, algorithms, or circuit application examples contained in these materials.
- All information contained in these materials, including product data, diagrams, charts, programs and algorithms represents information on products at the time of publication of these materials, and are subject to change by Mitsubishi Electric Corporation without notice due to product improvements or other reasons. It is therefore recommended that customers contact Mitsubishi Electric Corporation or an authorized Mitsubishi Semiconductor product distributor for the latest product information before purchasing a product listed herein.  
The information described here may contain technical inaccuracies or typographical errors. Mitsubishi Electric Corporation assumes no responsibility for any damage, liability, or other loss rising from these inaccuracies or errors.  
Please also pay attention to information published by Mitsubishi Electric Corporation by various means, including the Mitsubishi Semiconductor home page (<http://www.MitsubishiElectric.com/>).
- When using any or all of the information contained in these materials, including product data, diagrams, charts, programs, and algorithms, please be sure to evaluate all information as a total system before making a final decision on the applicability of the information and products. Mitsubishi Electric Corporation assumes no responsibility for any damage, liability or other loss resulting from the information contained herein.
- Mitsubishi Electric Corporation semiconductors are not designed or manufactured for use in a device or system that is used under circumstances in which human life is potentially at stake. Please contact Mitsubishi Electric Corporation or an authorized Mitsubishi Semiconductor product distributor when considering the use of a product contained herein for any specific purposes, such as apparatus or systems for transportation, vehicular, medical, aerospace, nuclear, or undersea repeater use.
- The prior written approval of Mitsubishi Electric Corporation is necessary to reprint or reproduce in whole or in part these materials.
- If these products or technologies are subject to the Japanese export control restrictions, they must be exported under a license from the Japanese government and cannot be imported into a country other than the approved destination.  
Any diversion or re-export contrary to the export control laws and regulations of Japan and/or the country of destination is prohibited.
- Please contact Mitsubishi Electric Corporation or an authorized Mitsubishi Semiconductor product distributor for further details on these materials or the products contained therein.