

< HVIC >

M81738FP

1200V HIGH VOLTAGE HALF BRIDGE DRIVER

DESCRIPTION

M81738FP is 1200V high voltage Power MOSFET and IGBT module driver for half bridge applications.

FEATURES

- Floating supply voltage up to 1200V
- Low quiescent power supply current
- Separate sink and source current output up to $\pm 1A$ (typ)
- Active Miller effect clamp NMOS with sink current up to 1A (typ)
- Input noise filters (HIN,LIN,FO_RST,FO)
- Over-current detection and output shutdown
- High side under voltage lockout
- FO pin which can input and output Fault signals to communicate with controllers and synchronize the shut down with other phases
- Active clamp (power supply surge clamp)
- 24pin SSOP-Lead package

APPLICATIONS

Power MOSFET and IGBT gate driver for Inverter or general purpose.

PIN CONFIGURATION (TOP VIEW)

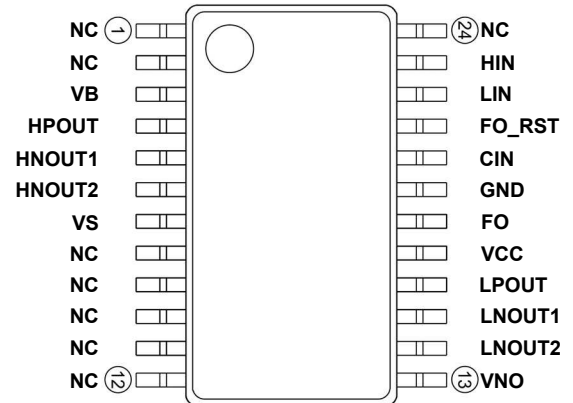

Outline:24P2Q

BLOCK DIAGRAM

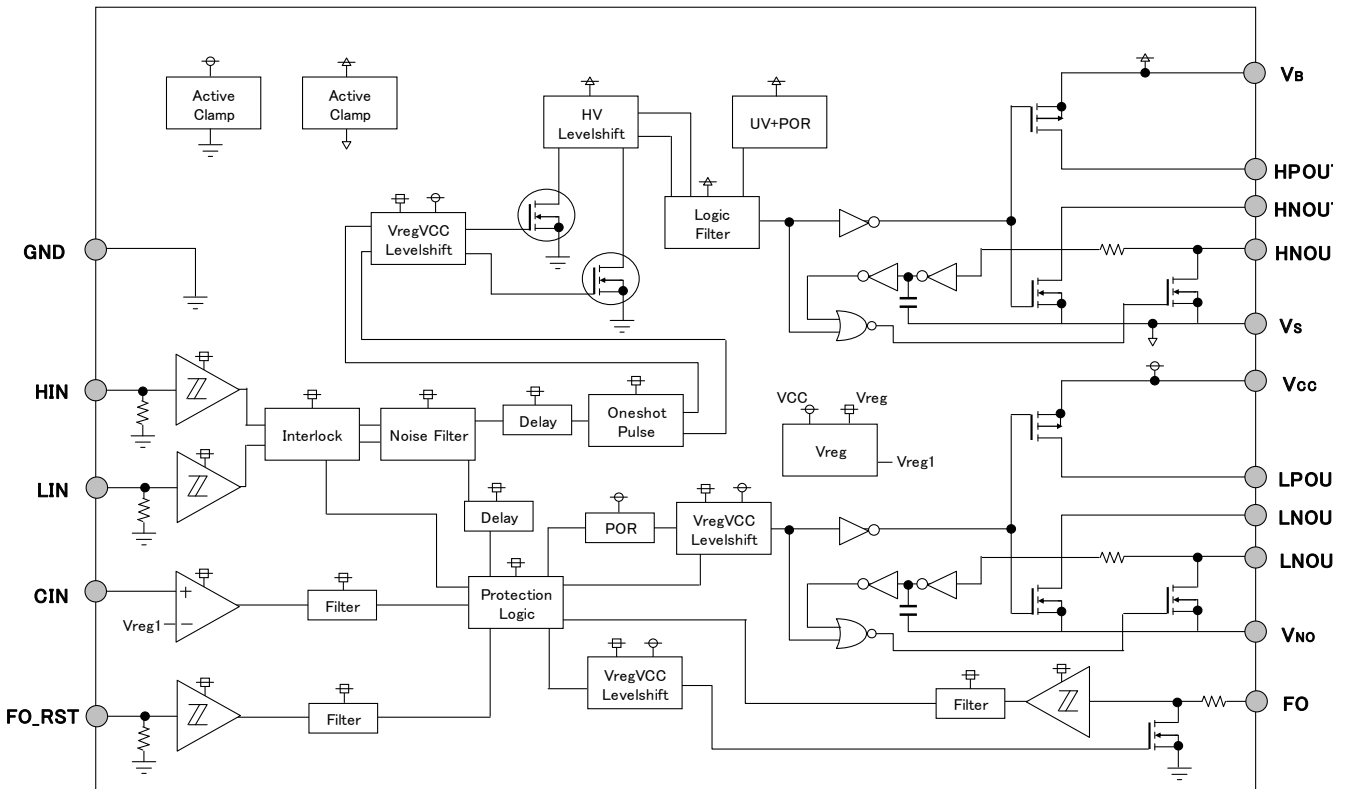

<HVIC>

M81738FP

1200V HIGH VOLTAGE HALF BRIDGE DRIVER

ABSOLUTE MAXIMUM RATINGS

Absolute maximum ratings indicate limitation beyond which destruction of device may occur. All voltage parameters are absolute voltage reference to GND unless otherwise specified.

Symbol	Parameter	Test conditions	Rating	Unit
V _B	High side floating supply absolute voltage		-0.5~1224	V
V _S	High side floating supply offset voltage		V _B -24~V _B +0.5	V
V _{BS}	High side floating supply voltage	V _{BS} =V _B -V _S	-0.5~24	V
V _{HO}	High side output voltage		V _S -0.5~V _B +0.5	V
V _{CC}	Low side fixed supply voltage		-0.5~24	V
V _{NO}	Power ground		V _{CC} -24~V _{CC} +0.5	V
V _{LO}	Low side output voltage		V _{NO} -0.5~V _{CC} +0.5	V
V _{IN}	Logic input voltage	HIN, LIN, FO_RST	-0.5~V _{CC} +0.5	V
V _{FO}	FO input/output voltage		-0.5~V _{CC} +0.5	V
V _{CIN}	CIN input voltage		-0.5~V _{CC} +0.5	V
dV _S /dt	Allowable offset voltage slew rate	V _S -GND	±50	V/ns
P _d	Package power dissipation	T _a = 25°C ,On our standard PCB	~1.11	W
K _θ	Linear derating factor	T _a ≥25°C ,On our standard PCB	~11.1	mW/°C
R _{th(j-a)}	Junction-ambient air thermal resistance	On our standard PCB	~90	°C/W
T _j	Junction temperature		-40~125	°C
T _{opr}	Operation temperature		-40~100	°C
T _{stg}	Storage temperature		-40~150	°C

RECOMMENDED OPERATING CONDITIONS

For proper operation the device should be used within the recommended conditions. All voltage parameters are absolute voltages referenced to GND unless otherwise specified.

Symbol	Parameter	Test conditions	Limits			Unit
			Min.	Typ.	Max.	
V _B	High side floating supply absolute voltage		V _S +13.5	V _S +15	V _S +20	V
V _S	High side floating supply offset voltage	V _{BS} > 13.5V	-5	-	900	V
V _{BS}	High side floating supply voltage	V _{BS} =V _B -V _S	13.5	15	20	V
V _{HO}	High side output voltage		V _S	-	V _S +20	V
V _{CC}	Low side fixed supply voltage		13.5	15	20	V
V _{NO}	Power ground		-0.5	-	5	V
V _{LO}	Low side output voltage		V _{NO}	-	V _{CC}	V
V _{IN}	Logic input voltage	HIN, LIN, FO_RST	0	-	V _{CC}	V
V _{FO}	FO input/output voltage		0	-	V _{CC}	V
V _{CIN}	CIN input voltage		0	-	5	V

THERMAL DERATING FACTOR CHARACTERISTIC

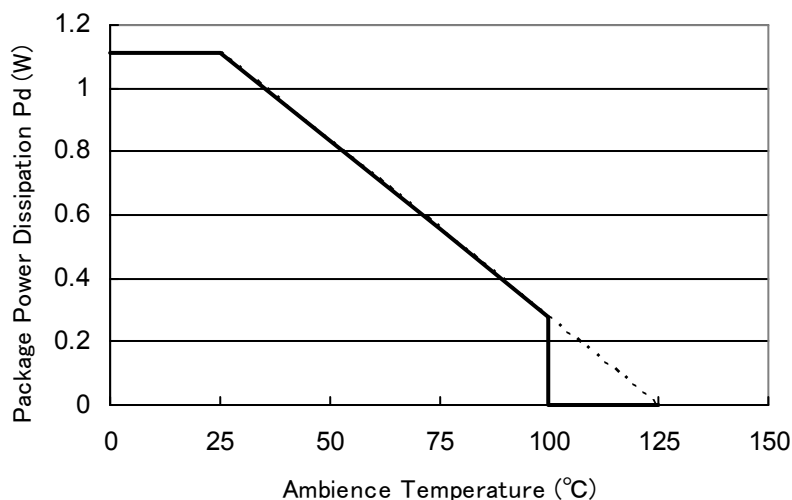

<HVIC>

M81738FP

1200V HIGH VOLTAGE HALF BRIDGE DRIVER

TYPICAL CONNECTION

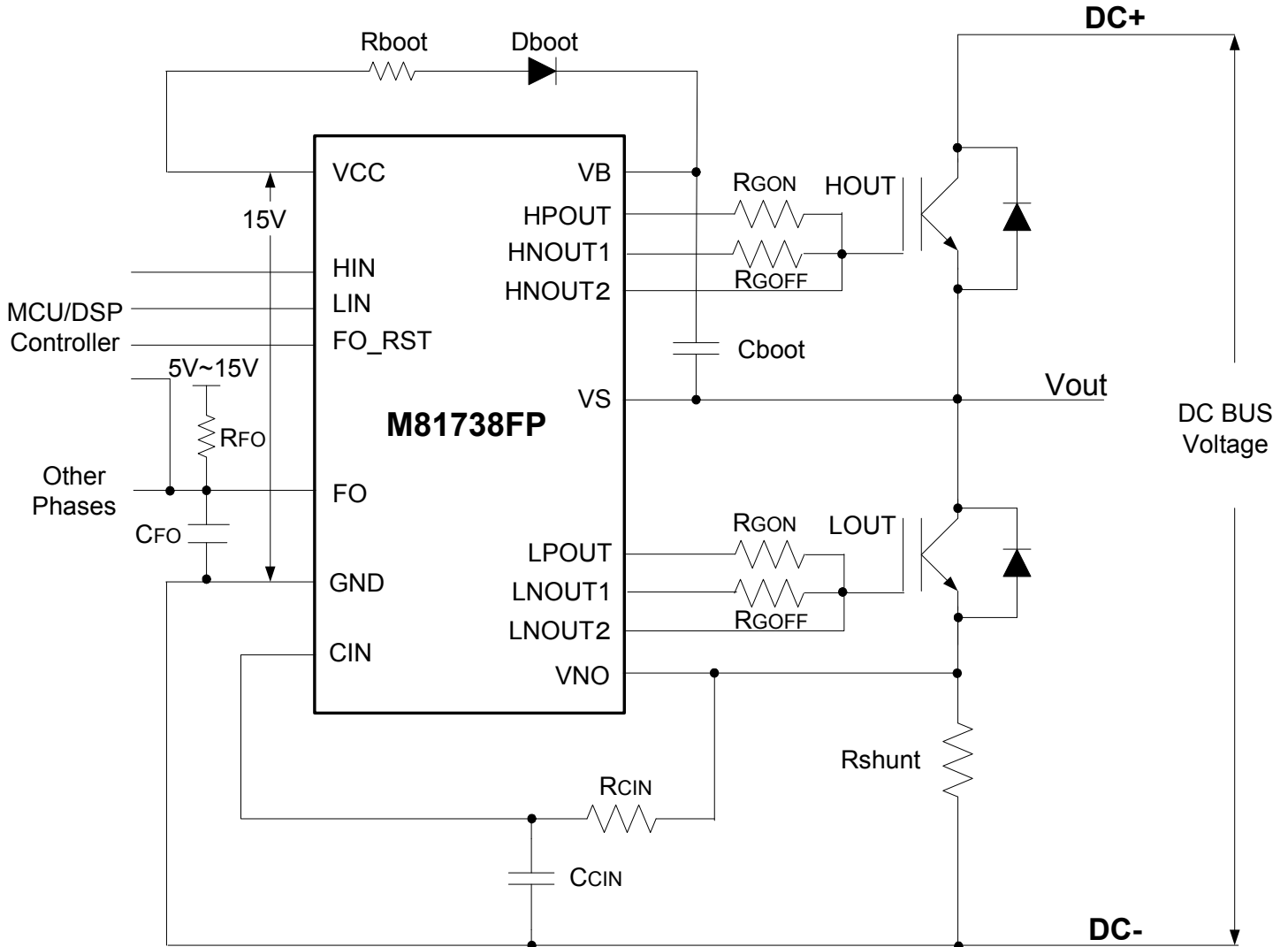

Note: If HVIC is working in high noise environment, it is recommended to connect a 1nF ceramic capacitor (C_{FO}) to FO pin.

<HVIC>

M81738FP**1200V HIGH VOLTAGE HALF BRIDGE DRIVER****ELECTRICAL CHARACTERISTICS (Ta=25 °C, V_{CC}=V_{BS}(=V_B-V_S)=15V, unless otherwise specified)**

Symbol	Parameter	Test conditions	Limits			Unit
			Min.	Typ.	Max.	
I _{FS}	High side leakage current	V _B = V _S = 1200V	-	-	10	μA
I _{BS}	V _{BS} quiescent supply current	HIN = LIN = 0V	-	0.5	0.8	mA
I _{CC}	V _{CC} quiescent supply current	HIN = LIN = 0V	-	1.0	1.5	mA
V _{OH}	High level output voltage	I _O = 0A, HPOUT, LPOUT	14.5	-	-	V
V _{OL}	Low level output voltage	I _O = 0A, HNOUT1, LNOUT1	-	-	0.5	V
V _{IH}	High level input threshold voltage	HIN, LIN, FO_RST	2.2	3.0	4.0	V
V _{IL}	Low level input threshold voltage	HIN, LIN, FO_RST	0.6	1.5	2.1	V
I _{IH}	High level input bias current	V _{IN} = 5V	0.6	1.0	1.4	mA
I _{IL}	Low level input bias current	V _{IN} = 0V	0.00	0.00	0.01	mA
tFilter	Input signals filter time	HIN on-pulse	80	200	500	ns
		HIN off-pulse	80	200	500	ns
		LIN on-pulse	80	200	500	ns
		LIN off-pulse	80	200	500	ns
		FO_RST on-pulse	80	200	500	ns
		FO off-pulse	80	200	500	ns
V _{HNO2}	High side active Miller clamp NMOS input threshold voltage	V _{IN} = 0V	2.0	3.4	5.0	V
V _{LNO2}	Low side active Miller clamp NMOS input threshold voltage	V _{IN} = 0V	6.0	7.6	9.0	V
tV _{NO2}	Active Miller clamp NMOS filter time	V _{IN} = 0V	-	400	-	ns
V _{OLFO}	Low level FO output voltage	I _{FO} = 1mA	-	-	0.95	V
V _{IHFO}	High level FO input threshold voltage		2.2	3.0	4.0	V
V _{ILFO}	Low level FO input threshold voltage		0.6	1.5	2.1	V
V _{BSuvr}	V _{BS} supply UV reset voltage		10.0	10.8	11.6	V
V _{BSuvt}	V _{BS} supply UV trip voltage		10.5	11.3	12.1	V
V _{BSuvh}	V _{BS} supply UV hysteresis voltage	V _{BSuvh} = V _{BSuvr} - V _{BSuvt}	0.2	0.5	0.8	V
tV _{BSuv}	V _{BS} supply UV filter time		4	8	16	μs
V _{CIN}	CIN trip voltage		0.40	0.5	0.60	V
V _{POR}	POR trip voltage		4.0	5.5	7.5	V
I _{OH}	Output high level short circuit pulsed current	HPOUT(LPOUT) = 0V, V _{IN} = 5V, PW ≤ 10μs	-	1	-	A
I _{OL1}	Output low level short circuit pulsed current	HNOUT1(LNOUT1) = 15V, V _{IN} = 0V, PW ≤ 10μs	-	-1	-	A
I _{OL2}	Active Miller clamp NMOS output low level short circuit pulsed current	HNOUT2(LNOUT2) = 15V, V _{IN} = 0V, PW ≤ 10μs	-	-1	-	A
R _{OH}	Output high level on resistance	I _O = 1A, R _{OH} = (V _{OH} - V _O)/I _O	-	15	-	Ω
R _{OL1}	Output low level on resistance	I _O = -1A, R _{OL1} = V _O /I _O	-	15	-	Ω
R _{OL2}	Active Miller clamp NMOS output low level on resistance	I _O = -1A, R _{OL2} = V _O /I _O	-	15	-	Ω
tdLH(HO)	High side turn-on propagation delay	HPOUT short to HNOUT1 and HNOUT2, CL = 1nF	1.00	1.27	1.80	μs
tdHL(HO)	High side turn-off propagation delay	HPOUT short to HNOUT1 and HNOUT2, CL = 1nF	0.90	1.21	1.80	μs
tdLH(LO)	Low side turn-on propagation delay	LPOUT short to LNOUT1 and LNOUT2, CL = 1nF	1.00	1.39	1.90	μs
tdHL(LO)	Low side turn-off propagation delay	LPOUT short to LNOUT1 and LNOUT2, CL = 1nF	0.90	1.19	1.70	μs
tr	Output turn-on rise time	CL = 1nF	10	40	80	ns
tf	Output turn-off fall time	CL = 1nF	10	40	80	ns
ΔtdLH	Delay matching, high side turn-on and low side turn-off	tdLH(HO) - tdHL(LO)	-100	80	300	ns
ΔtdHL	Delay matching, high side turn-off and low side turn-on	tdLH(LO) - tdHL(HO)	-20	180	400	ns
V _{clamp}	Active clamp voltage	V _{CC} - GND, V _B - V _S	24	-	-	V

Note: Typ. is not specified.

<HVIC>

M81738FP

1200V HIGH VOLTAGE HALF BRIDGE DRIVER

FUNCTION TABLE (Q: Keep previous status)

HIN	LIN	FO_RST	CIN	FO (Input)	V _{BS} /UV·POR	V _{CC} /POR	HOUT	LOUT	FO (Output)	Behavioral status
L	L	L	L	-	H	H	L	L	H	
L	H	L	L	-	H	H	L	H	H	
H	L	L	L	-	H	H	H	L	H	
H	H	L	L	-	H	H	Q	Q	H	Interlock active
X	H	X	H	-	X	H	L	L	L	CIN tripping when LIN = H
X	L	X	H	-	X	H	Q	Q	H	CIN not tripping when LIN = L
X	X	X	X	L	X	H	L	L	-	Output shuts down when FO = L
X	X	X	X	-	X	L	L	L	H	V _{CC} power reset
X	L	L	L	-	L	H	L	L	H	V _{BS} power reset
X	H	L	L	-	L	H	L	H	H	V _{BS} power reset is tripping when LIN = H

Note1 : "L" status of V_{BS}/UV indicates a high side UV condition; "L" status of V_{CC}/POR indicates a V_{CC} power reset condition.

2 : In the case of both input signals (HIN and LIN) are "H", output signals (HOUT and LOUT) keep previous status.

3 : X (HIN) : L→H or H→L. Other : H or L.

4 : Output signal (HOUT) is triggered by the edge of input signal.

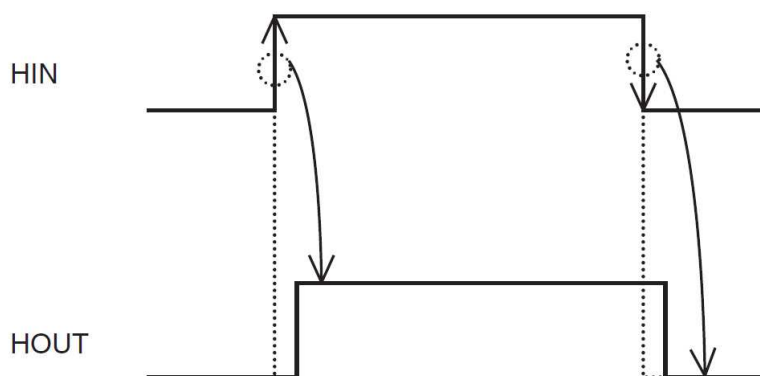

FUNCTIONAL DESCRIPTION

1. INPUT/OUTPUT TIMING DIAGRAM

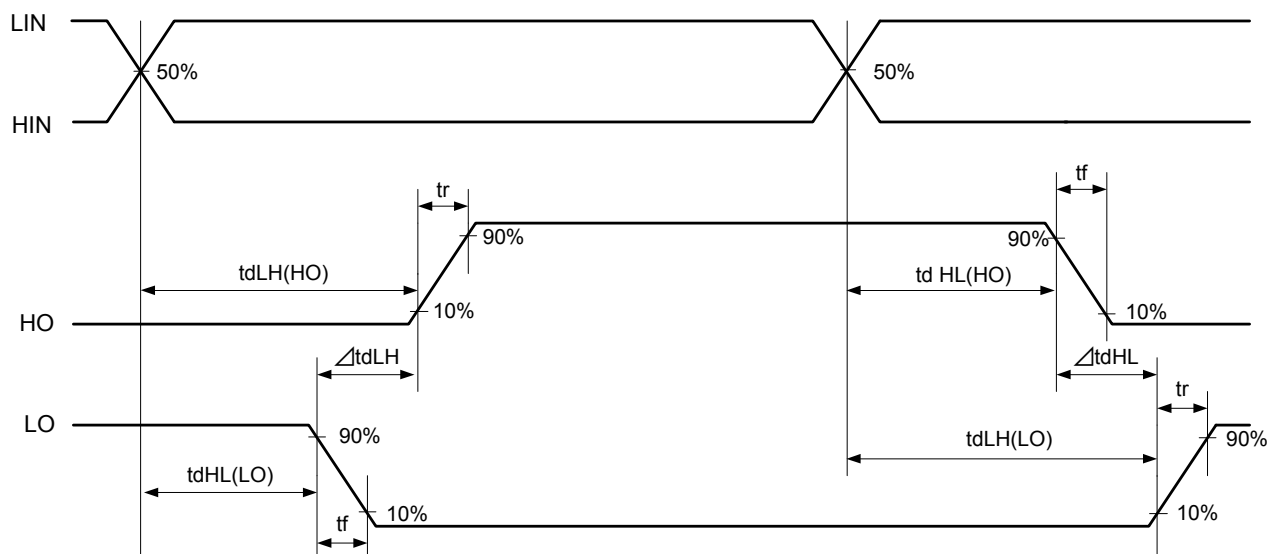

<HVIC>

M81738FP**1200V HIGH VOLTAGE HALF BRIDGE DRIVER****2. INPUT INTERLOCK TIMING DIAGRAM**

When the input signals (HIN/LIN) are high level at the same time, the outputs (HOUT/LOUT) keep their previous status.

But if signals (HIN/LIN) are going to high level simultaneously, HIN signals will get active and cause HOUT to enter "H" status.

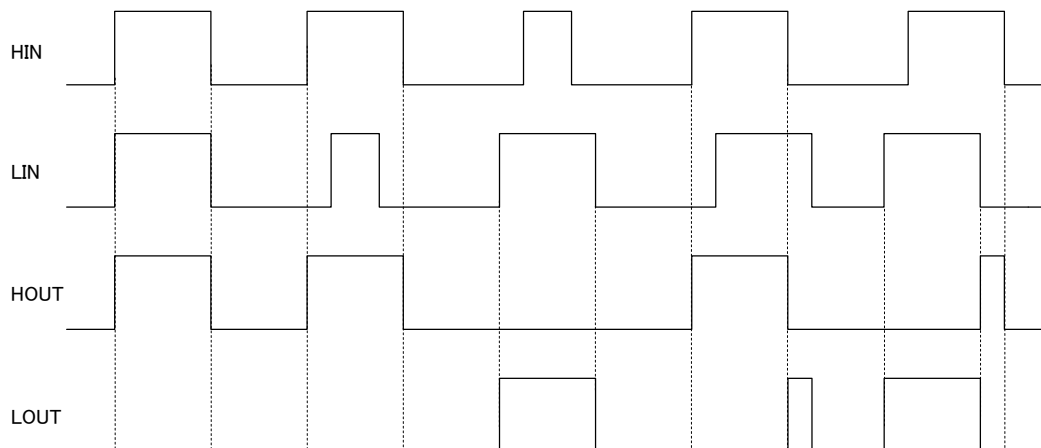

Note1 :The minimum input pulse width at HIN/LIN should be to more than 500ns (because of HIN/LIN input noise filter circuit).

Note2 :If a high-high status of input signals (HIN/LIN) is ended with only one input signal entering low level and another still being in high level, the output will enter high-low status after the delay match time (not shown in the figure above).

Note3 :Delay times between input and output signals are not shown in the figure above.

3. SHORT CIRCUIT PROTECTION TIMING DIAGRAM

When an over-current is detected by exceeding the threshold at the CIN and LIN is at high level at the same time, the short circuit protection will get active and shutdown the outputs while FO will issue a low level (indicating a fault signal). The fault output latch is reset by a high level signal at FO_RST pin and then FO will return to high level while the output of the driver will respond to the following active input signal.

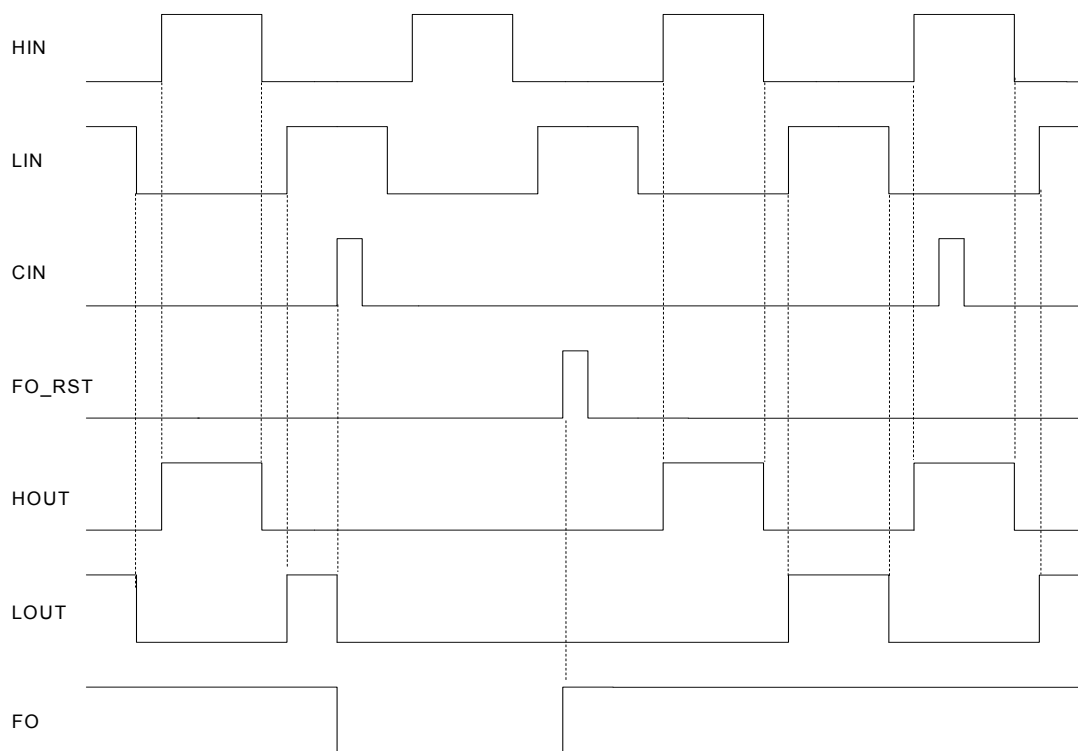

Note1 : Delay times between input and output signals are not shown in the figure above.

Note2 : The minimum FO_RST pulse width should be more than 500ns (because of FO_RST input filter circuit).

<HVIC>

M81738FP**1200V HIGH VOLTAGE HALF BRIDGE DRIVER****4. FO INPUT TIMING DIAGRAM**

When FO is pulled down to low level in case the FO of other phases becomes low level (fault happened) or the MCU/DSP sets FO to low level, the outputs (HOUT, LOUT) of the driver will be shut down. As soon as FO goes high again, the output will respond to the following active input signal.

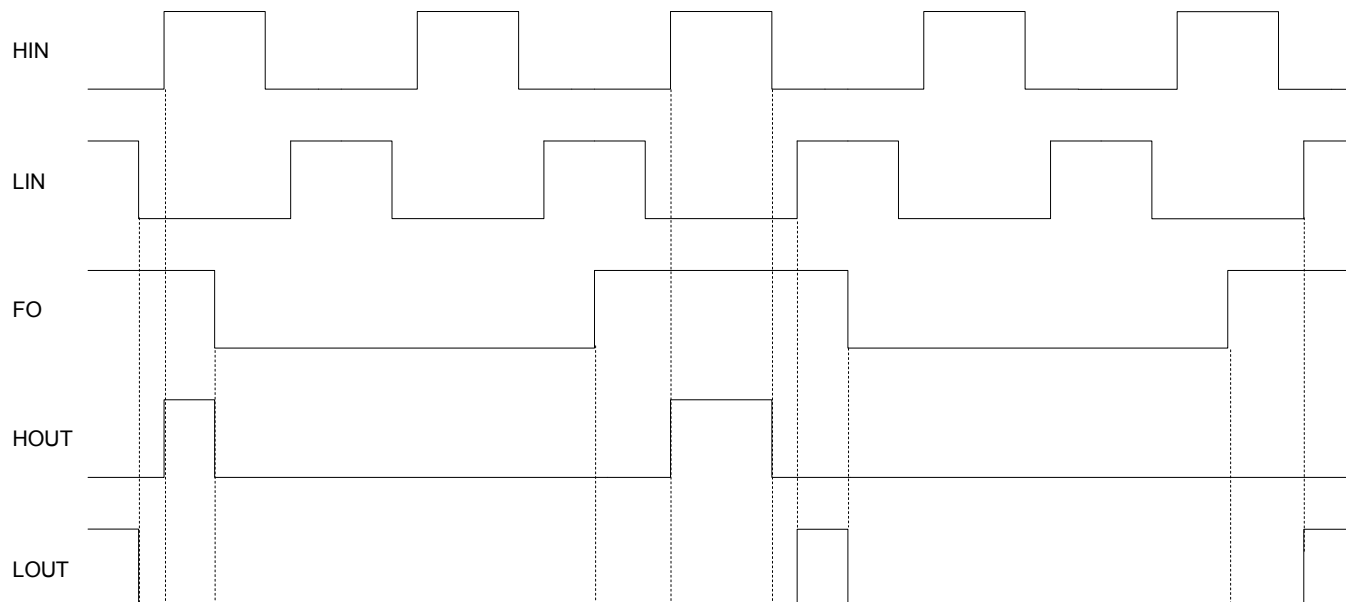

Note1 :Delay times between input and output signals are not shown in the figure above.

Note2 :The minimum FO pulse width should be more than ns (because of FO input filter circuit).

5. LOW SIDE V_{CC} SUPPLY POWER RESET SEQUENCE

When the V_{CC} supply voltage is lower than power reset trip voltage, the power reset gets active and the outputs (LOUT) become "L". As soon as the V_{CC} supply voltage goes higher than the power reset trip voltage, the outputs will respond to the following active input signals.

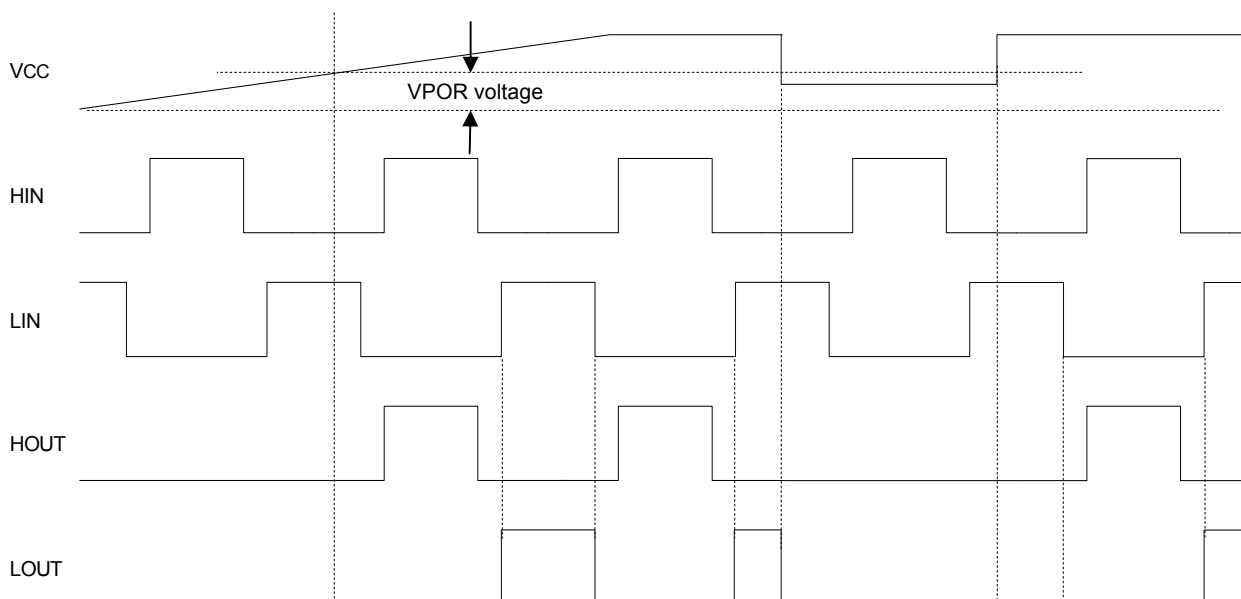

Note1 :Delay times between input and output signals are not shown in the figure above.

<HVIC>

M81738FP

1200V HIGH VOLTAGE HALF BRIDGE DRIVER

6. HIGH SIDE V_{BS} SUPPLY UNDER VOLTAGE LOCKOUT SEQUENCE

When V_{BS} supply voltage drops below the V_{BS} supply UV trip voltage and the duration in this status exceeds the V_{BS} supply UV filter time, the output of the high side is locked. As soon as the V_{BS} supply voltage rises above the V_{BS} supply UV reset voltage, the output will respond to the following active HIN signal.

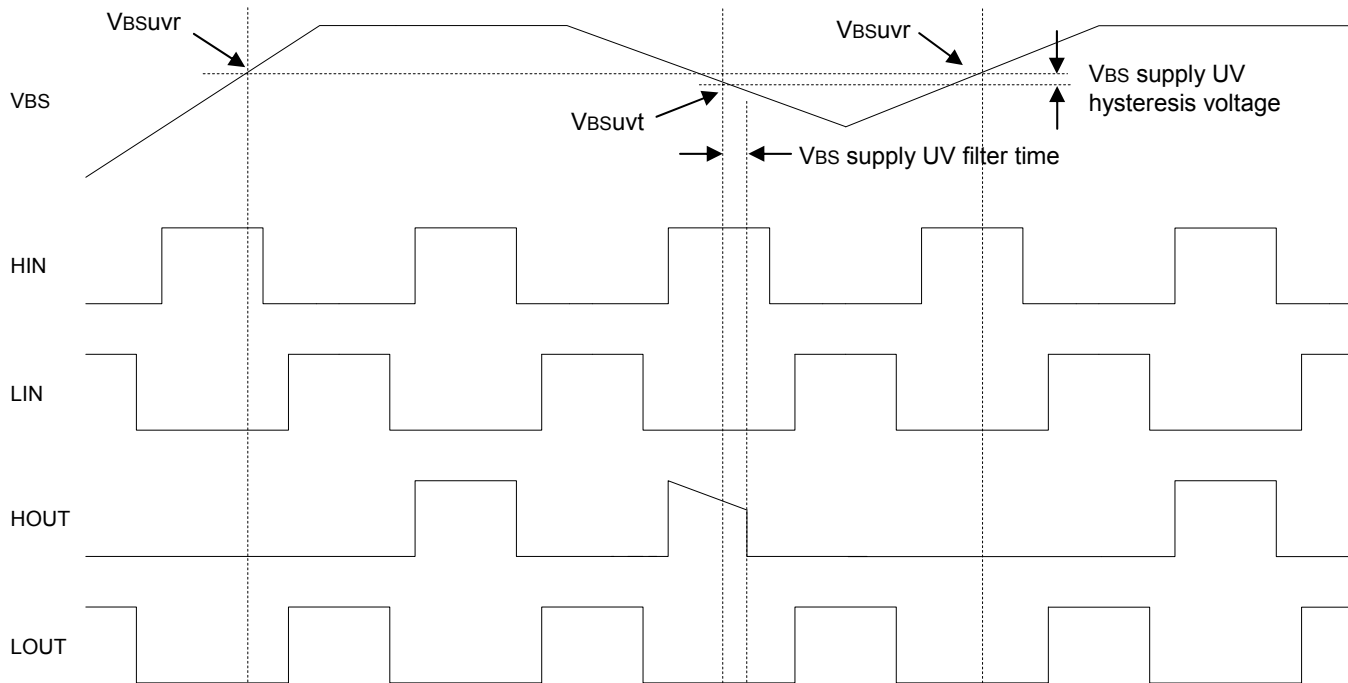

Note1 :Delay times between input and output signals are not shown in the figure above.

7. POWER START-UP SEQUENCE

At power supply start-up the following sequence is recommended when bootstrap supply topology is used.

- (1). Apply V_{CC} .
- (2). Make sure that FO is at high level.
- (3). Set LIN to high level and HIN to low level so that bootstrap capacitor could be charged.
- (4). Set LIN to low level.

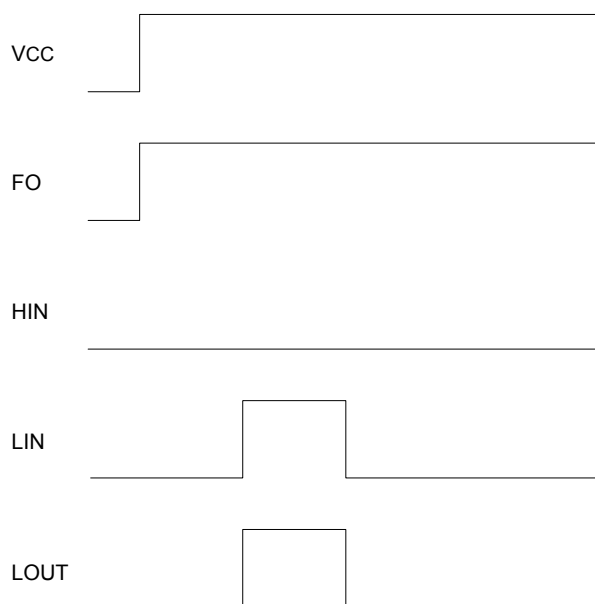

Note : If two power supply are used for supplying V_{CC} and V_{BS} individually, it is recommended to set V_{CC} first and then set V_{BS} .

<HVIC>

M81738FP

1200V HIGH VOLTAGE HALF BRIDGE DRIVER

8. ACTIVE MILLER EFFECT CLAMP NMOS OUTPUT TIMING DIAGRAM

The structure of the output driver stage is shown in following figure. This circuit structure employs a solution for the problem of the Miller current through C_{res} in IGBT switching applications. Instead of driving the IGBT gate to a negative voltage to increase the safety margin, this circuit structure uses a NMOS to establish a low impedance path to prevent the self-turn-on due to the parasitic Miller capacitor in power switches.

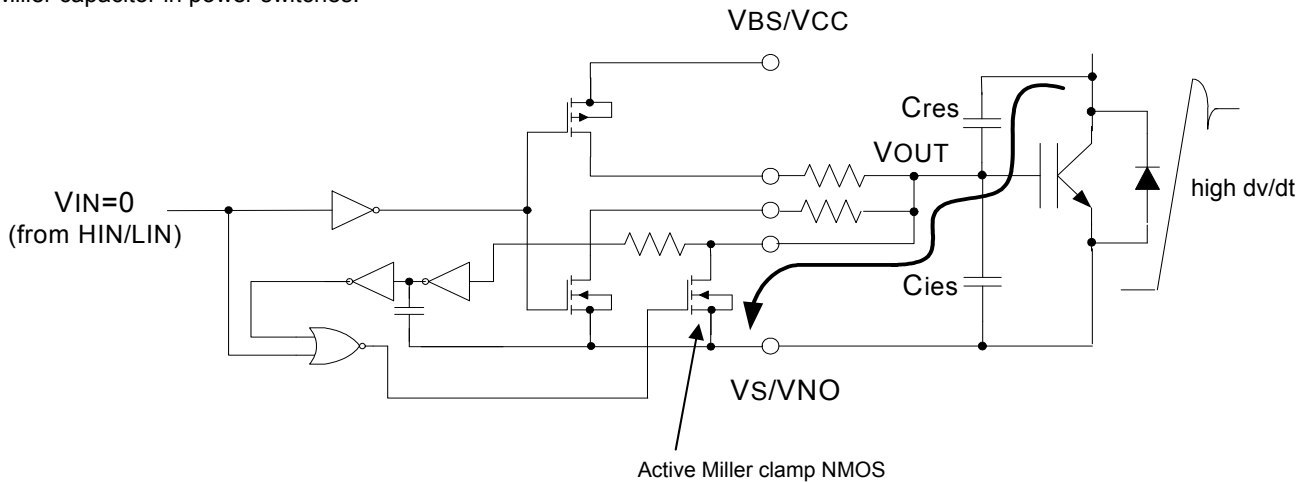

When HIN/LIN is at low level and the voltage of the VOUT (IGBT gate voltage) is below active Miller effect clamp NMOS input threshold voltage, the active Miller effect clamp NMOS is being turned on and opens a low resistive path for the Miller current through C_{res} .

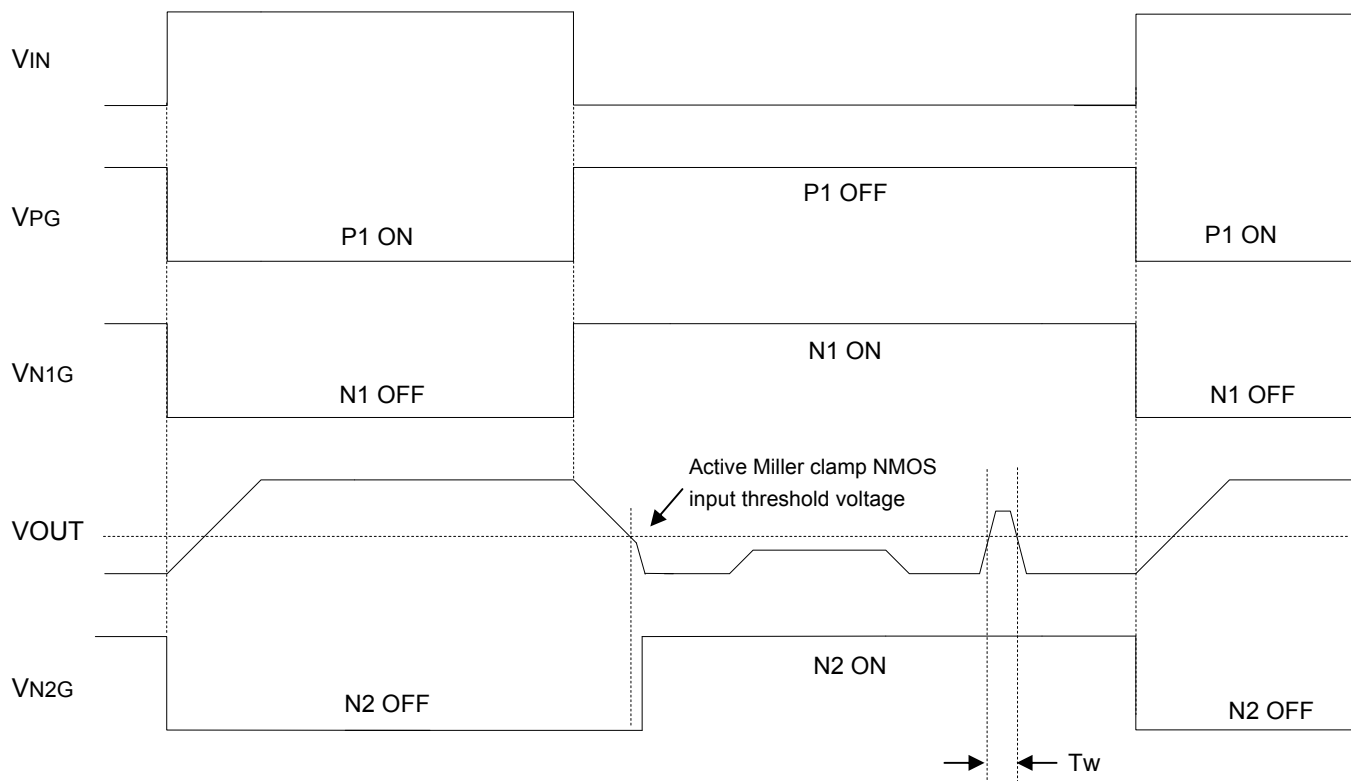

Active Miller effect clamp NMOS keeps turn-on if T_w does not exceed active Miller clamp NMOS filter time

<HVIC>

M81738FP

1200V HIGH VOLTAGE HALF BRIDGE DRIVER

INTERNAL DIODE CLAMP CIRCUITS FOR INPUT AND OUTPUT PINS

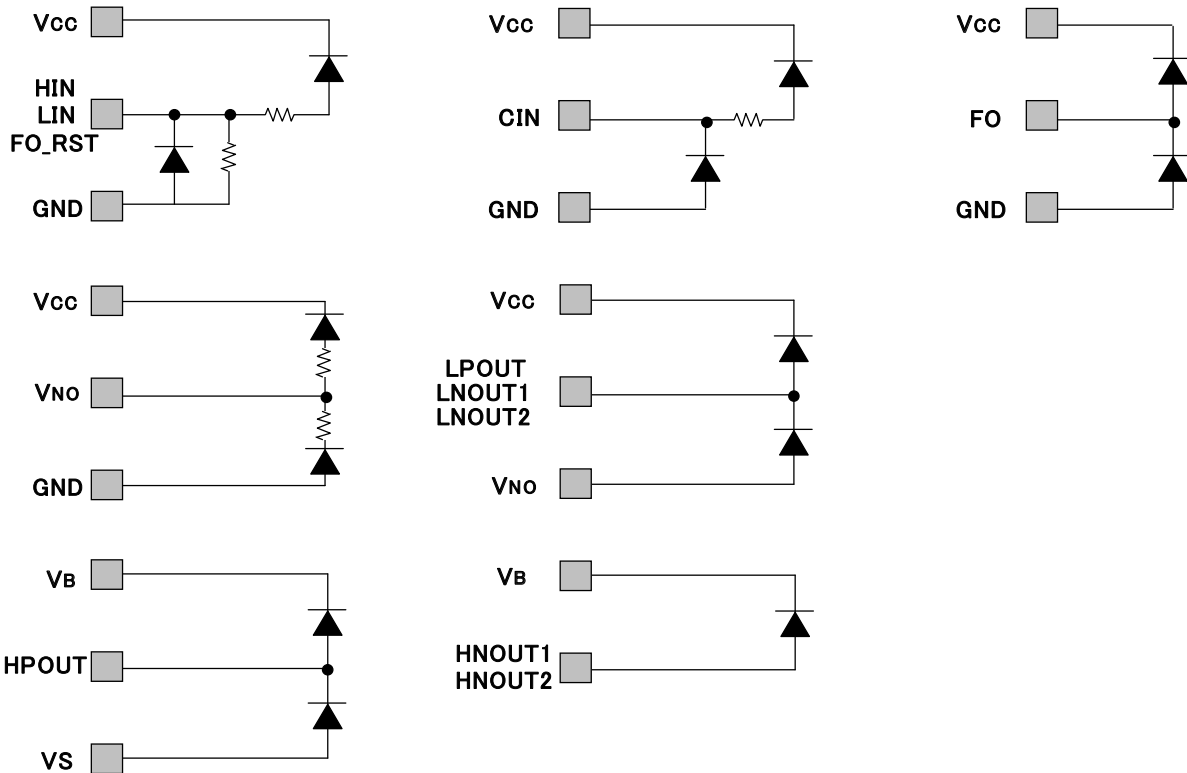

PACKAGE OUTLINE

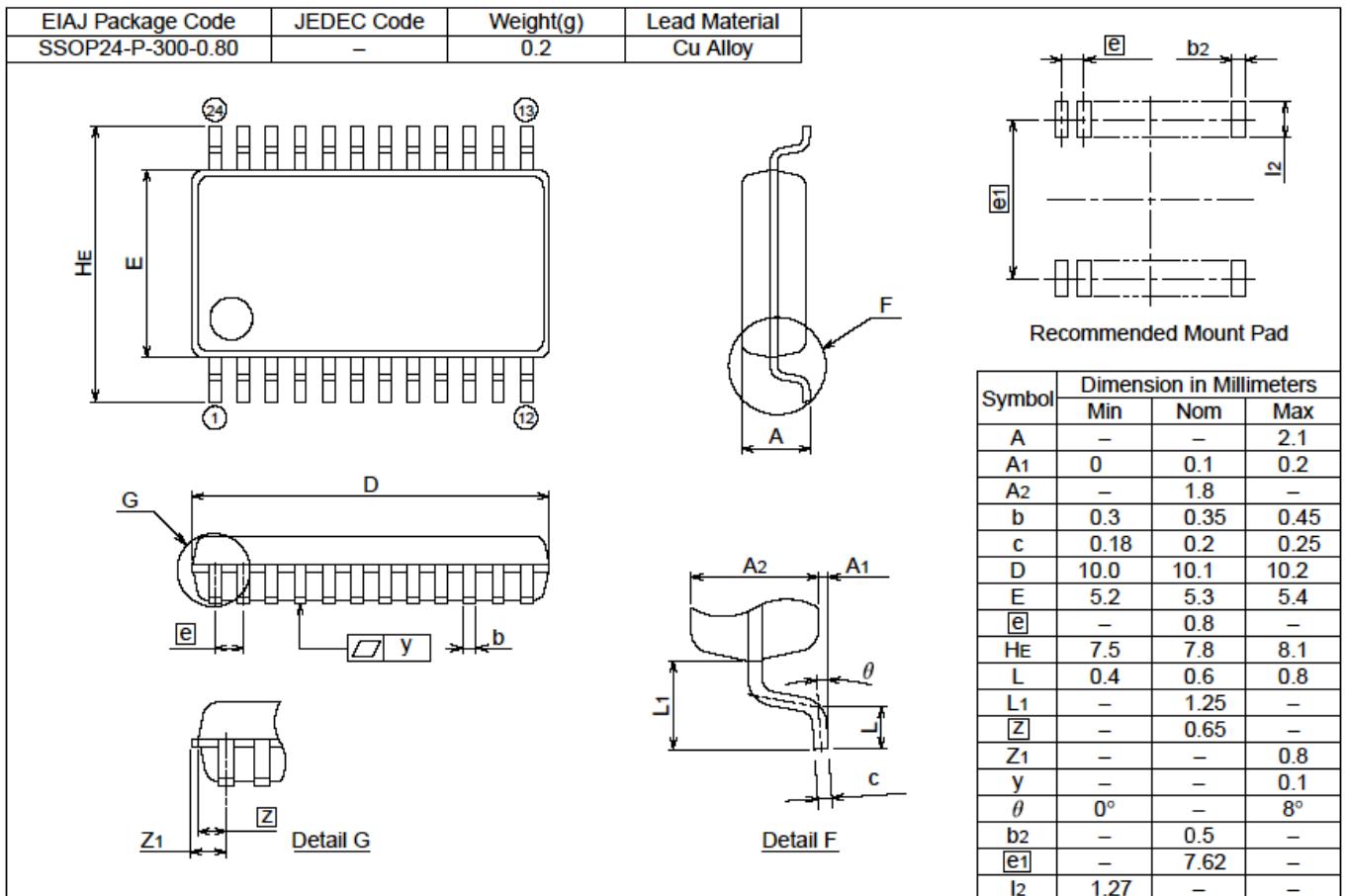

<HVIC>

M81738FP

1200V HIGH VOLTAGE HALF BRIDGE DRIVER

Main Revision for this Edition

No.	Date	Revision	
		Pages	Points

<HVIC>

M81738FP**1200V HIGH VOLTAGE HALF BRIDGE DRIVER****Keep safety first in your circuit designs!**

Mitsubishi Electric Corporation puts the maximum effort into making semiconductor products better and more reliable, but there is always the possibility that trouble may occur with them. Trouble with semiconductors may lead to personal injury, fire or property damage. Remember to give due consideration to safety when making your circuit designs, with appropriate measures such as (i) placement of substitutive, auxiliary circuits, (ii) use of non-flammable material or (iii) prevention against any malfunction or mishap.

Notes regarding these materials

- These materials are intended as a reference to assist our customers in the selection of the Mitsubishi semiconductor product best suited to the customer's application; they do not convey any license under any intellectual property rights, or any other rights, belonging to Mitsubishi Electric Corporation or a third party.
- Mitsubishi Electric Corporation assumes no responsibility for any damage, or infringement of any third-party's rights, originating in the use of any product data, diagrams, charts, programs, algorithms, or circuit application examples contained in these materials.
- All information contained in these materials, including product data, diagrams, charts, programs and algorithms represents information on products at the time of publication of these materials, and are subject to change by Mitsubishi Electric Corporation without notice due to product improvements or other reasons. It is therefore recommended that customers contact Mitsubishi Electric Corporation or an authorized Mitsubishi Semiconductor product distributor for the latest product information before purchasing a product listed herein.
The information described here may contain technical inaccuracies or typographical errors. Mitsubishi Electric Corporation assumes no responsibility for any damage, liability, or other loss rising from these inaccuracies or errors.
Please also pay attention to information published by Mitsubishi Electric Corporation by various means, including the Mitsubishi Semiconductor home page (<http://www.MitsubishiElectric.com/>).
- When using any or all of the information contained in these materials, including product data, diagrams, charts, programs, and algorithms, please be sure to evaluate all information as a total system before making a final decision on the applicability of the information and products. Mitsubishi Electric Corporation assumes no responsibility for any damage, liability or other loss resulting from the information contained herein.
- Mitsubishi Electric Corporation semiconductors are not designed or manufactured for use in a device or system that is used under circumstances in which human life is potentially at stake. Please contact Mitsubishi Electric Corporation or an authorized Mitsubishi Semiconductor product distributor when considering the use of a product contained herein for any specific purposes, such as apparatus or systems for transportation, vehicular, medical, aerospace, nuclear, or undersea repeater use.
- The prior written approval of Mitsubishi Electric Corporation is necessary to reprint or reproduce in whole or in part these materials.
- If these products or technologies are subject to the Japanese export control restrictions, they must be exported under a license from the Japanese government and cannot be imported into a country other than the approved destination.
Any diversion or re-export contrary to the export control laws and regulations of Japan and/or the country of destination is prohibited.
- Please contact Mitsubishi Electric Corporation or an authorized Mitsubishi Semiconductor product distributor for further details on these materials or the products contained therein.