

M81735FP

HIGH VOLTAGE HALF BRIDGE DRIVER

DESCRIPTION

M81735FP is high voltage Power MOSFET and IGBT module driver for half bridge applications.

FEATURES

- FLOATING SUPPLY VOLTAGE600V
- OUTPUT CURRENT+600mA/-570mA
- HALF BRIDGE DRIVER
- UNDERVOLTAGE LOCKOUT
- SOP-16 PACKAGE

APPLICATIONS

MOSFET and IGBT module inverter driver for PDP, HID lamp, refrigerator, air-conditioner, washing machine, AC servomotor and general purpose.

PIN CONFIGURATION (TOP VIEW)

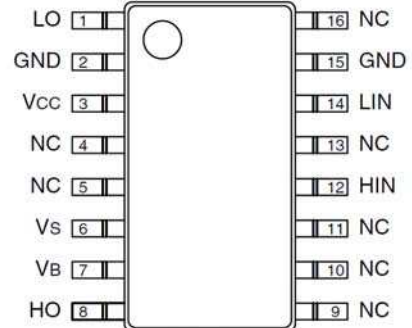

Outline:16P2N NC: No Connection

BLOCK DIAGRAM

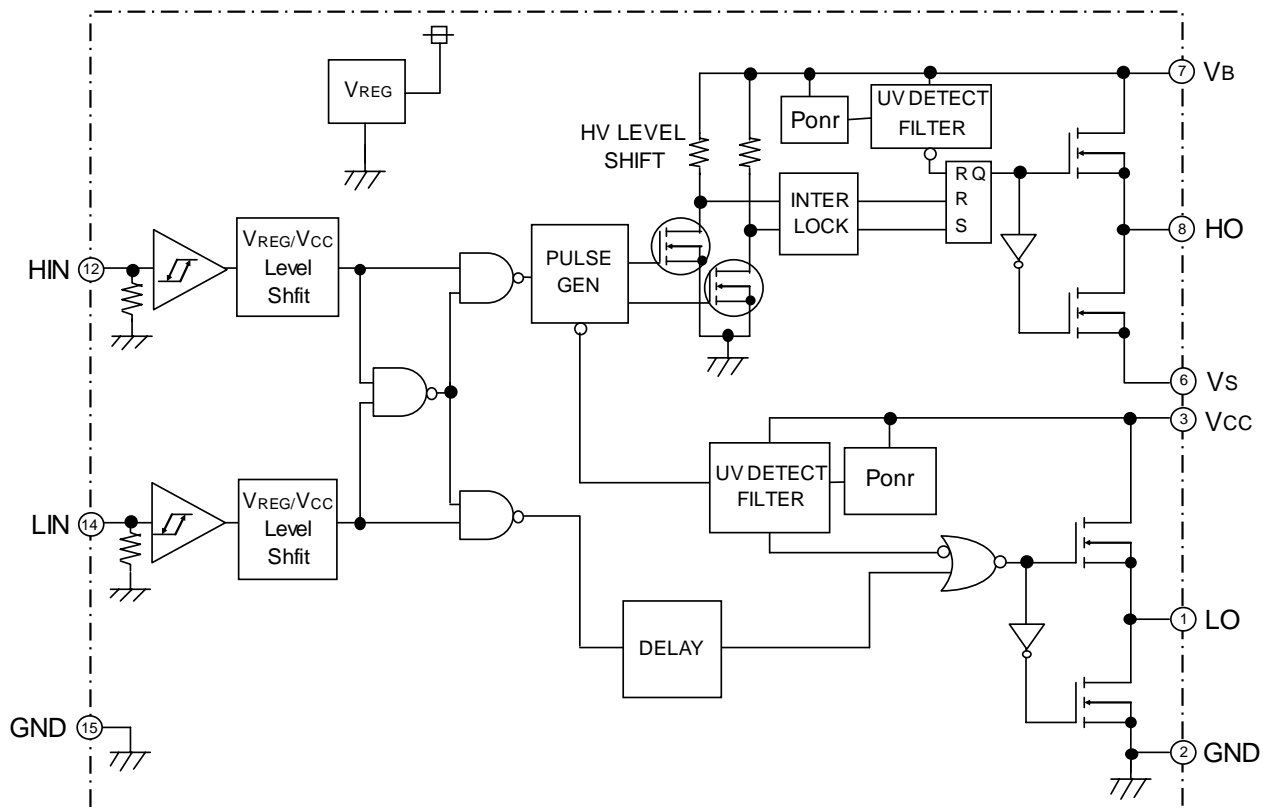

ABSOLUTE MAXIMUM RATINGS (Ta=25°C unless otherwise specified)

Symbol	Parameter	Test conditions	Ratings	Unit
V _B	High Side Floating Supply Absolute Voltage		-0.5~624	V
V _S	High Side Floating Supply Offset Voltage		V _B -24~V _B +0.5	V
V _{BS}	High Side Floating Supply Voltage	V _{BS} =V _B -V _S	-0.5~24	V
V _{HO}	High Side Output Voltage		V _S -0.5~V _B +0.5	V
V _{CC}	Low Side Fixed Supply Voltage		-0.5~24	V
V _{LO}	Low Side Output Voltage		-0.5~ V _{CC} +0.5	V
V _{IN}	Logic Input Voltage	HIN, LIN	-0.5~ V _{CC} +0.5	V
dV _S /dt	Allowable Offset Voltage Transient		±50	V/ns
P _d	Package Power Dissipation	Ta= 25 °C ,On Board	0.9	W
Kθ	Linear Derating Factor	Ta> 25 °C ,On Board	-7.2	mW/°C
Rth(j-c)	Junction-Case Thermal Resistance		50	°C/W
T _J	Junction Temperature		-40~150	°C
T _{opr}	Operation Temperature		-40~125	°C
T _{stg}	Storage Temperature		-55~150	°C
TL	Solder Heatproof	RoHS Correspondence	255:10s,max 260	°C

RECOMMENDED OPERATING CONDITIONS

Symbol	Parameter	Test conditions	Limits			Unit
			Min.	Typ.	Max.	
V _B	High Side Floating Supply Absolute Voltage		V _S +10	—	V _S +20	V
V _S	High Side Floating Supply Offset Voltage	V _B >10V	-5	—	500	V
V _{BS}	High Side Floating Supply Voltage	V _{BS} =V _B -V _S	10	—	20	V
V _{HO}	High Side Output Voltage		V _S	—	V _B	V
V _{CC}	Low Side Fixed Supply Voltage		10	—	20	V
V _{LO}	Low Side Output Voltage		0	—	V _{CC}	V
V _{IN}	Logic Input Voltage	HIN, LIN	0	—	V _{CC}	V

* For proper operation, the device should be used within the recommended conditions

THERMAL DERATING FACTOR CHARACTERISTIC (MAXIMUM RATING)

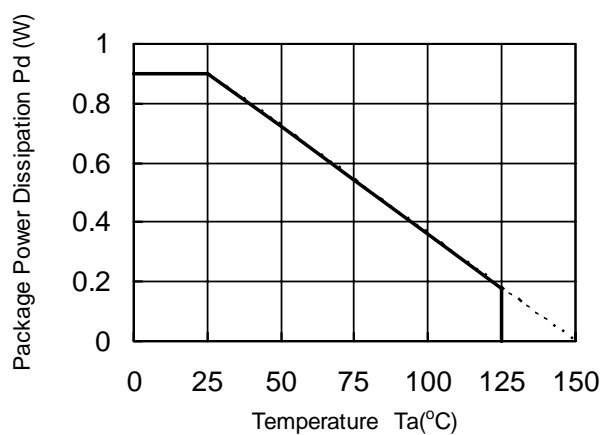

ELECTRICAL CHARACTERISTICS (Ta=25°C, V_{CC}=V_{BS}(=V_B-V_S)=15V, unless otherwise specified)

Symbol	Parameter	Test conditions	Limits			Unit
			Min.	Typ.*	Max.	
I _{FS}	Floating Supply Leakage Current	V _B = V _S = 600V	—	—	1.0	μA
I _{BS}	V _{BS} Standby Current	HIN = LIN = 0V	—	0.22	0.5	mA
I _{CC}	V _{CC} Standby Current	HIN = LIN = 0V	0.2	0.5	1.0	mA
V _{OH}	High Level Output Voltage	I _O = -200mA, LO, HO	13.8	14.4	—	V
V _{OL}	Low Level Output Voltage	I _O = 200mA, LO, HO	—	—	0.1	V
V _{IH}	High Level Input Threshold Voltage	HIN, LIN	4.0	—	—	V
V _{IL}	Low Level Input Threshold Voltage	HIN, LIN	—	—	1.0	V
V _{INh}	Input Hysteresis Voltage	V _{INh} = V _{IH} - V _{IL}	1.0	1.5	2.0	V
I _{IH}	High Level Input Bias Current	V _{IN} = 5V	—	25	75	μA
I _{IL}	Low Level Input Bias Current	V _{IN} = 0 V	—	—	1.0	μA
V _{BSuvr}	V _{BS} Supply UV Reset Voltage		7.4	8.6	9.8	V
V _{BSuvh}	V _{BS} Supply UV Hysteresis Voltage		0.2	0.5	0.8	V
t _{VBSuv}	V _{BS} Supply UV Filter Time		—	7.5	—	μs
V _{CCuvr}	V _{CC} Supply UV Reset Voltage		7.4	8.6	9.8	V
V _{CCuvh}	V _{CC} Supply UV Hysteresis Voltage		0.2	0.5	0.8	V
t _{VCCuv}	V _{CC} Supply UV Filter Time		—	7.5	—	μs
I _{OH}	Output High Level Short Circuit Pulsed Current	V _O = 0V, V _{IN} = 5V, PW < 10μs	-340	-570	-800	mA
I _{OL}	Output Low Level Short Circuit Pulsed Current	V _O = 15V, V _{IN} = 0V, PW < 10μs	360	600	840	mA
R _{OH}	Output High Level On Resistance	I _O = -200mA, R _{OH} = (V _{CC} -V _O)/I _O	18	35	45	Ω
R _{OL}	Output Low Level On Resistance	I _O = 200mA, R _{OL} = V _O /I _O	6	12	16	Ω
V _{ponr}	Power reset voltage		—	—	6.0	V
t _{Ponr(FIL)}	Power reset filter time		300	—	—	ns
t _{dLH(HO)}	High Side Turn-On Propagation Delay	CL = 1000pF between HO-V _S	90	125	160	ns
t _{dHL(HO)}	High Side Turn-Off Propagation Delay	CL = 1000pF between HO-V _S	85	115	145	ns
t _{rH}	High Side Turn-On Rise Time	CL = 1000pF between HO-V _S	27.5	55	110	ns
t _{fH}	High Side Turn-Off Fall Time	CL = 1000pF between HO-V _S	15	30	60	ns
t _{dLH(LO)}	Low Side Turn-On Propagation Delay	CL = 1000pF between LO-GND	90	125	160	ns
t _{dHL(LO)}	Low Side Turn-Off Propagation Delay	CL = 1000pF between LO-GND	85	115	145	ns
t _{rL}	Low Side Turn-On Rise Time	CL = 1000pF between LO-GND	27.5	55	110	ns
t _{fL}	Low Side Turn-Off Fall Time	CL = 1000pF between LO-GND	15	30	60	ns
Δt _{dLH}	Delay Matching, High Side and Low Side Turn-On	t _{dLH(HO)} - t _{dLH(LO)}	—	0	30	ns
Δt _{dHL}	Delay Matching, High Side and Low Side Turn-Off	t _{dHL(HO)} - t _{dHL(LO)}	—	0	30	ns

* Typ. is not specified.

TIMING REQUIREMENT

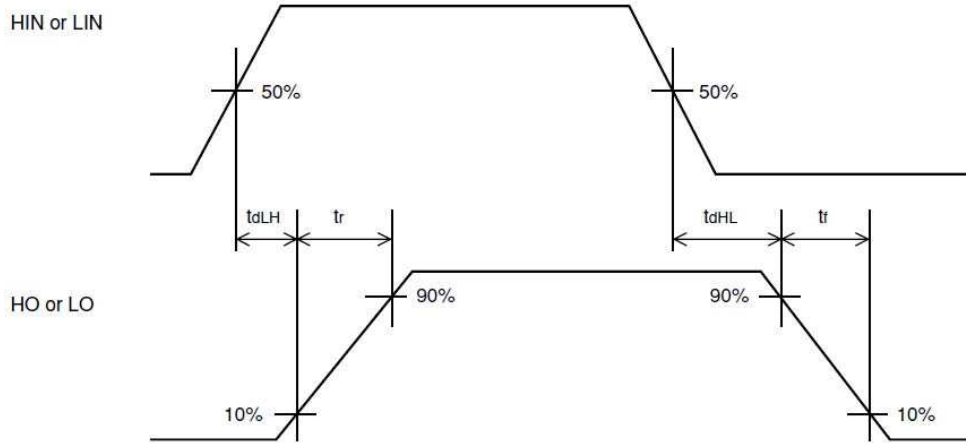

FUNCTION TABLE

HIN	LIN	V _{BS} UV	V _{CC} UV	HO	LO	Behavioral state
H→L	L	H	H	L	L	LO = HO = Low
H→L	H	H	H	L	H	LO = High
L→H	L	H	H	H	L	HO = High
L→H	H	H	H	L	L	LO = HO = Low
X	L	L	H	L	L	HO = Low, V _{BS} UV
X	H	L	H	L	H	LO = High, V _{BS} UV
H→L	X	H	L	L	L	LO = Low, V _{CC} UV
L→H	X	H	L	L	L	HO = LO = Low, V _{CC} UV

Note1 : "L" state of V_{BS} UV, V_{CC} UV means that UV trip voltage.

2 : In the case of both input signals (HIN and LIN) are "H", output signals (HO and LO) become "L".

3 : X (HIN) : L→H or H → L. X(LIN) : H or L.

4 : Output signal (HO) is triggered by the edge of input signal.

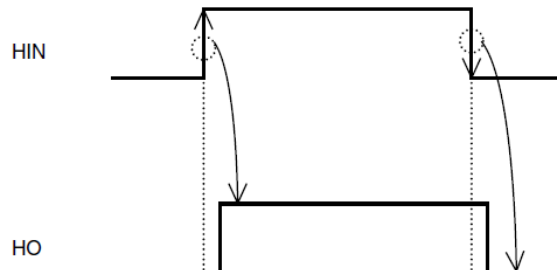

TIMING DIAGRAM

1. Input/Output Timing Diagram

HIGH ACTIVE (When input signal (HIN or LIN) is "H", then output signal (HO or LO) is "H".)

In the case of both input signals (HIN and LIN) are "H", output signals (HO and LO) become "L".

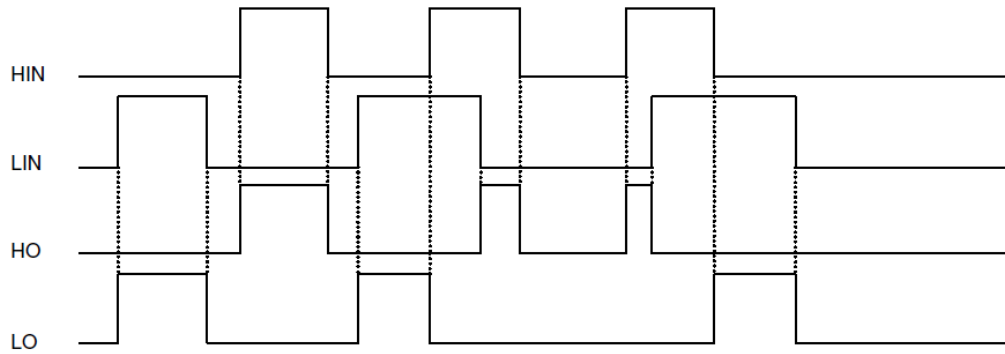

2. V_{CC} (V_{BS}) Supply Under Voltage Lockout Timing Diagram

If V_{CC} supply voltage drops below UV trip voltage ($V_{CCUVT} = V_{CCUVR} - V_{CCUVH}$) for V_{CC} supply UV filter time, output signal becomes "L". As soon as V_{CC} supply voltage rises over UV reset voltage, output signal LO becomes "H".

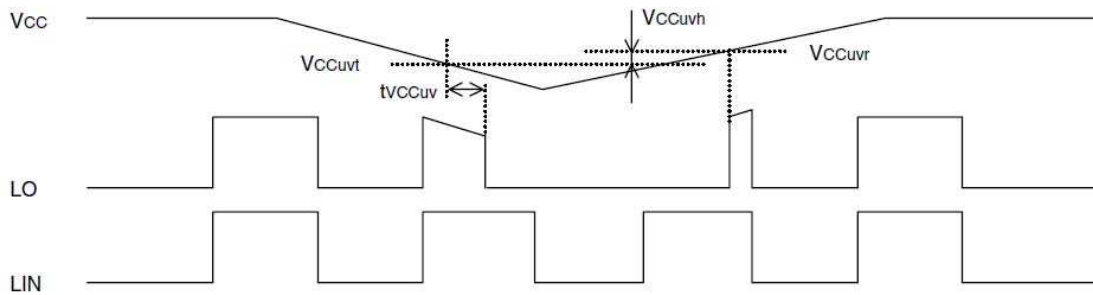

If V_{CC} supply voltage drops below UV trip voltage ($V_{CCUVT} = V_{CCUVR} - V_{CCUVH}$) for V_{CC} supply UV filter time, output signal becomes "L". As soon as V_{CC} supply voltage rises over UV reset voltage, output signal HO becomes "H" if input signal is "H". ($V_{CC} > V_{BS}$)

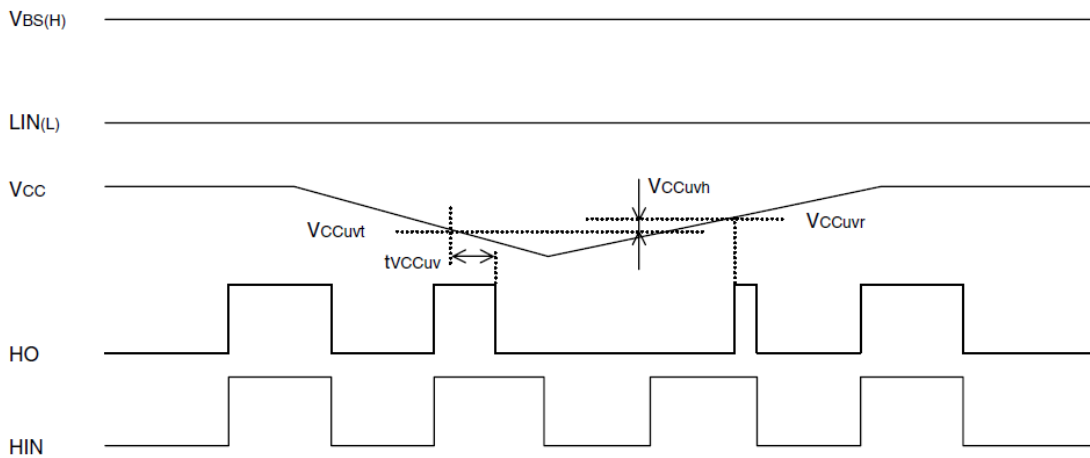

If V_{BS} supply voltage drops below UV trip voltage ($V_{BSuvt} = V_{BSuvr} - V_{BSuvh}$) for V_{BS} supply UV filter time, output signal becomes "L". As soon as V_{BS} supply voltage rises over UV reset voltage, output signal HO becomes "H" at following "H" edge of input signal.

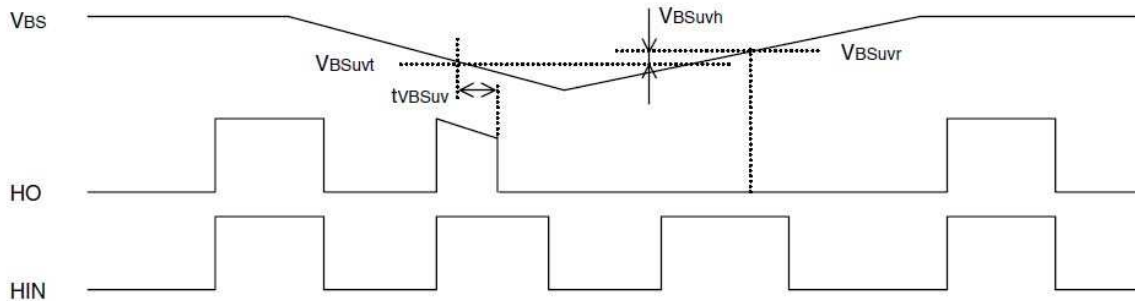

3. Allowable Supply Voltage Transient

It is recommended to supply V_{CC} firstly and supply V_{BS} secondly. In the case of shutting off supply voltage, please shut off V_{BS} firstly and shut off V_{CC} secondly. When applying V_{CC} and V_{BS} , power supply should be applied slowly. If it rises rapidly, output signal (HO or LO) may be malfunction.

PACKAGE OUTLINE

