

< HVIC >

M81729JFP

HIGH VOLTAGE HALF BRIDGE DRIVER FOR AUTOMOTIVE APPLICATIONS

DESCRIPTION

M81729JFP is high voltage Power MOSFET and IGBT gate driver for half bridge applications.

FEATURES

- Floating Supply Voltage 600V
- Output Current +120mA/-250mA (min)
- Half Bridge Driver
- SOP-8 Package

APPLICATIONS

MOSFET and IGBT gate driver.

PIN CONFIGURATION (TOP VIEW)

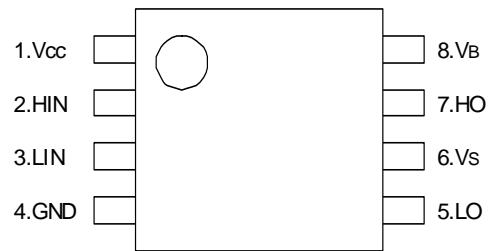

Outline:8P2S

BLOCK DIAGRAM

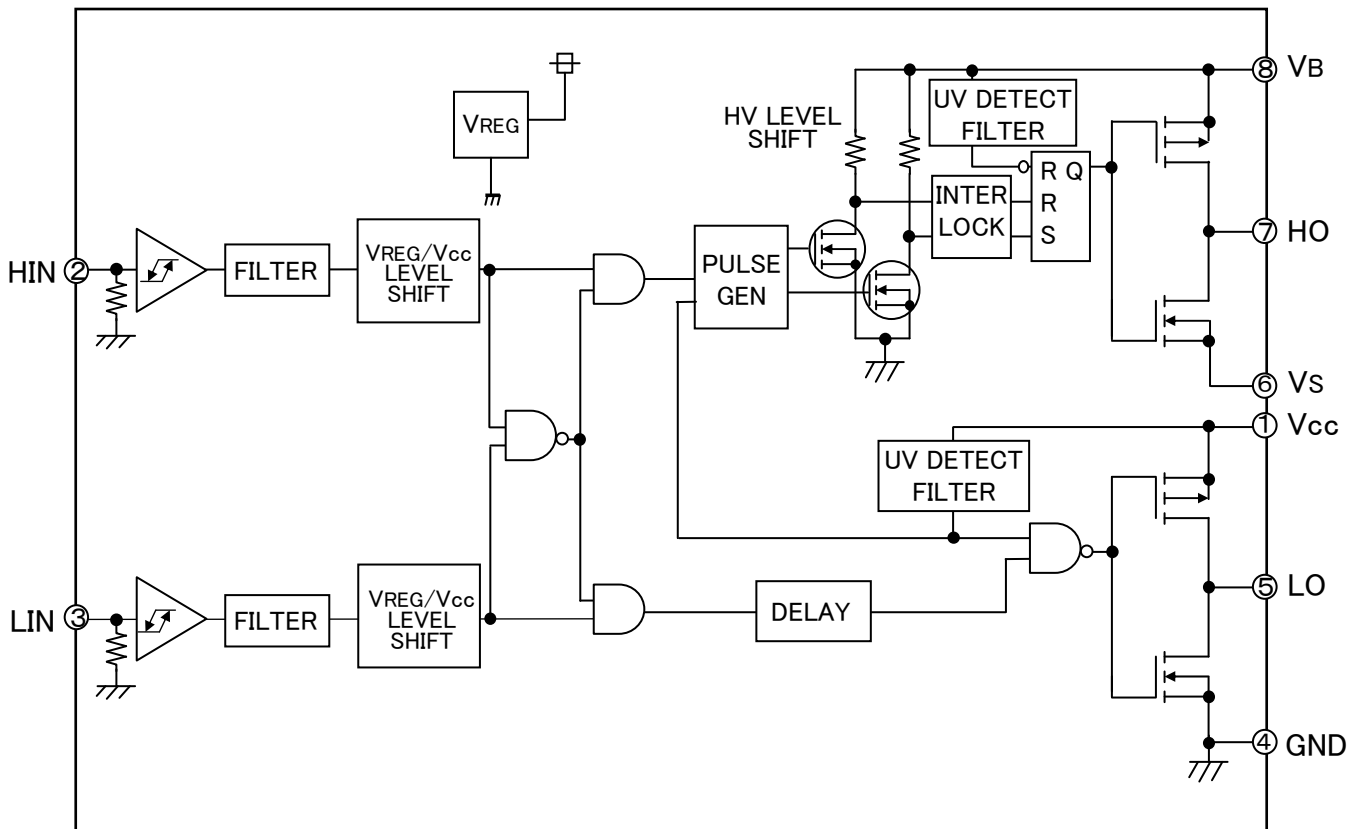

ABSOLUTE MAXIMUM RATINGS (Ta=25°C unless otherwise specified)

Symbol	Parameter	Test conditions	Ratings	Unit
V _B	High Side Floating Supply Absolute Voltage		-0.5 ~ 624	V
V _S	High Side Floating Supply Offset Voltage		V _B -24 ~ V _B +0.5	V
V _{BS}	High Side Floating Supply Voltage	V _{BS} =V _B -V _S	-0.5 ~ 24	V
V _{HO}	High Side Output Voltage		V _S -0.5 ~ V _B +0.5	V
V _{CC}	Low Side Fixed Supply Voltage		-0.5 ~ 24	V
V _{LO}	Low Side Output Voltage		-0.5 ~ V _{CC} +0.5	V
V _{IN}	Logic Input Voltage	HIN,LIN	-0.5 ~ V _{CC} +0.5	V
P _D	Package Power Dissipation	Ta= 25 °C ,On Board	0.6	W
Kθ	Linear Derating Factor	Ta> 25 °C ,On Board	4.8	mW/°C
Rth(j-c)	Junction-Case Thermal Resistance		50	°C/W
T _J	Junction Temperature		-40 ~ +150 *	°C
T _{opr}	Operation Temperature		-40 ~ +125	°C
T _{stg}	Storage Temperature		-40 ~ +150	°C
TL	Solder Heatproof	RoHS Correspondence	255:10s,max 260	°C

*When temperature exceeds 125 °C, please make VS voltage less than 500V.

RECOMMENDED OPERATING CONDITIONS

Symbol	Parameter	Test conditions	Limits			Unit
			Min.	Typ.	Max.	
V _B	High Side Floating Supply Absolute Voltage		V _S +10	—	V _S +20	V
V _S	High Side Floating Supply Offset Voltage	T _J ≤ 125 °C	0	—	550	V
		T _J > 125 °C	0	—	500	V
V _{BS}	High Side Floating Supply Voltage	V _{BS} =V _B -V _S	10	—	20	V
V _{HO}	High Side Output Voltage		V _S	—	V _B	V
V _{CC}	Low Side Fixed Supply Voltage		10	—	20	V
V _{LO}	Low Side Output Voltage		0	—	V _{CC}	V
V _{IN}	Logic Input Voltage	HIN,LIN	0	—	7	V

* For proper operation, the device should be used within the recommended conditions

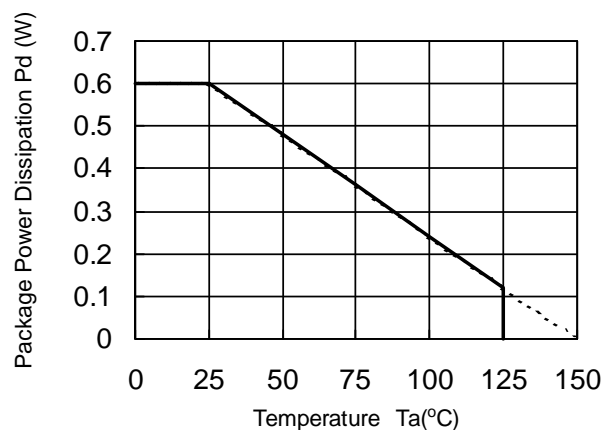
THERMAL DERATING FACTOR CHARACTERISTIC (MAXIMUM RATING)

ELECTRICAL CHARACTERISTICS (Ta=-40~125°C, V_{CC}=V_{BS}(=V_B-V_S)=15V, unless otherwise specified)

Symbol	Parameter	Test conditions	Limits			Unit
			Min.	Typ.*	Max.	
I _{FS}	Floating Supply Leakage Current	V _B = V _S = 600V	—	—	1.0	μA
I _{BS}	V _{BS} Standby Current	HIN= LIN= 0V	—	0.2	0.5	mA
I _{CC}	V _{CC} Standby Current	HIN= LIN= 0V	0.2	0.6	1.0	mA
V _{OH}	High Level Output Voltage	I _O = -20mA, LO, HO	13.6	14.2	—	V
V _{OL}	Low Level Output Voltage	I _O = 20mA, LO, HO	—	0.3	0.6	V
V _{IH}	High Level Input Threshold Voltage		2.7	—	—	V
V _{IL}	Low Level Input Threshold Voltage		—	—	0.8	V
I _{IH}	High Level Input Bias Current	V _{IN} = 5V	—	25	100	μA
I _{IL}	Low Level Input Bias Current	V _{IN} = 0V	—	—	2	μA
V _{BSuvr}	V _{BS} Supply UV Reset Voltage		8.0	8.9	9.8	V
V _{BSuvt}	V _{BS} Supply UV Trip Voltage		7.4	8.2	9.0	V
V _{BSuvh}	V _{BS} Supply UV Hysteresis Voltage		0.5	0.7	—	V
t _{VBSuv}	V _{BS} Supply UV Filter Time		—	7.5	—	μs
V _{CCuvr}	V _{CC} Supply UV Reset Voltage		8.0	8.9	9.8	V
V _{CCuvt}	V _{CC} Supply UV Trip Voltage		7.4	8.2	9.0	V
V _{CCuvh}	V _{CC} Supply UV Hysteresis Voltage		0.5	0.7	—	V
t _{VCCuv}	V _{CC} Supply UV Filter Time		—	7.5	—	μs
I _{OH}	Output High Level Short Circuit Pulsed Current	V _O = 0V, V _{IN} = 5V, PW < 10μs**	120	200	—	mA
I _{OL}	Output Low Level Short Circuit Pulsed Current	V _O = 15V, V _{IN} = 0V, PW < 10μs ** (T _j ≤ 125 °C)	250	350	—	mA
R _{OH}	Output High Level On Resistance	I _O = -20mA, R _{OH} = (V _{CC} - V _O) / I _O	—	40	70	Ω
R _{OL}	Output Low Level On Resistance	I _O = 20mA, R _{OL} = V _O / I _O	—	15	30	Ω
t _{dLH(HO)}	High Side Turn-On Propagation Delay	CL = 1000pF between HO-V _S , 25 °C CL = 1000pF between HO-V _S	—	450	650	ns
t _{dHL(HO)}	High Side Turn-Off Propagation Delay	CL = 1000pF between HO-V _S , 25 °C CL = 1000pF between HO-V _S	—	450	650	ns
t _{rH}	High Side Turn-On Rise Time	CL = 1000pF between HO-V _S	—	130	220	ns
t _{fH}	High Side Turn-Off Fall Time	CL = 1000pF between HO-V _S	—	50	80	ns
t _{dLH(LO)}	Low Side Turn-On Propagation Delay	CL = 1000pF between LO-GND, 25 °C CL = 1000pF between LO-GND	—	450	650	ns
t _{dHL(LO)}	Low Side Turn-Off Propagation Delay	CL = 1000pF between LO-GND, 25 °C CL = 1000pF between LO-GND	—	450	650	ns
t _{rL}	Low Side Turn-On Rise Time	CL = 1000pF between LO-GND	—	130	220	ns
t _{fL}	Low Side Turn-Off Fall Time	CL = 1000pF between LO-GND	—	50	80	ns
Δt _{dLH}	Turn-On Propagation Delay Matching	t _{dLH(HO)} - t _{dLH(LO)} , 25 °C t _{dLH(HO)} - t _{dLH(LO)}	—	0	30	ns
Δt _{dHL}	Turn-Off Propagation Delay Matching	t _{dHL(HO)} - t _{dHL(LO)} , 25 °C t _{dHL(HO)} - t _{dHL(LO)}	—	0	30	ns
t _{inon}	On Input Filter Time	Convex Pulse	150	250	350	ns
		Concave Pulse	250	350	450	ns
t _{inoff}	Off Input Filter Time	Convex Pulse	150	250	350	ns
		Concave Pulse	250	350	450	ns
ΔP _{WIO}	Difference of Input Pulse Width and Output Pulse Width	P _{W(IN)} - P _{W(OUT)}	—	—	100	ns

*Typ. is not specified.

**The short circuit pulse cannot be entered continuously.

M81729JFP

HIGH VOLTAGE HALF BRIDGE DRIVER FOR AUTOMOTIVE APPLICATIONS

TIMING REQUIREMENT (INPUT FUREQUENCY : 200kHz(duty50%) or less)

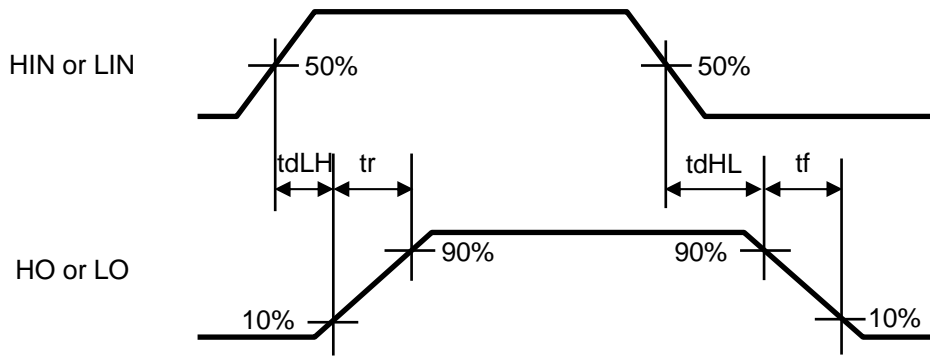

FUNCTION TABLE (X:H or L)

HIN	LIN	V _{BS} UV	V _{CC} UV	HO	LO	Behavioral state
H → L	L	H	H	L	L	LO = HO = LOW
H → L	H	H	H	L	H	LO = HIGH
L → H	L	H	H	H	L	HO = HIGH
L → H	H	H	H	L	L	LO = HO = LOW
X	L	L	H	L	L	HO = LOW , V _{BS} UV tripped
X	H	L	H	L	H	LO = HIGH , V _{BS} UV tripped
H → L	X	H	L	L	L	LO = LOW , V _{CC} UV tripped
L → H	X	H	L	L	L	HO = LO = LOW , V _{CC} UV tripped

Note1 : "L" state of V_{BS} UV, V_{CC} UV means that UV trip voltage.

2 : IN the case of both input signals (LIN and HIN) are "H", output signals (LO and HO) become "L".

3. X(HIN):L→H or H→L. X(LIN):H or L.

4. Output signal (HO) is triggered by the edge of input signal.

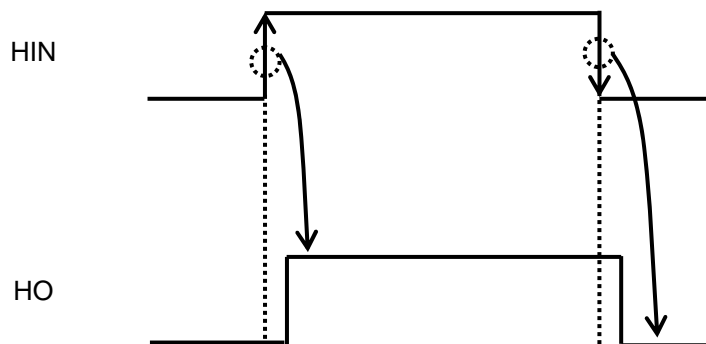

TIMING DIAGRAM

1. Input/Output Timing Diagram

HIGN ACTHVE (When input signal (HIN or LIN) is "H", then output signal (HO or LO) is "H".)

In the case of both input signals (HIN and LIN) are "H", output signals (HO and LO) become "L".

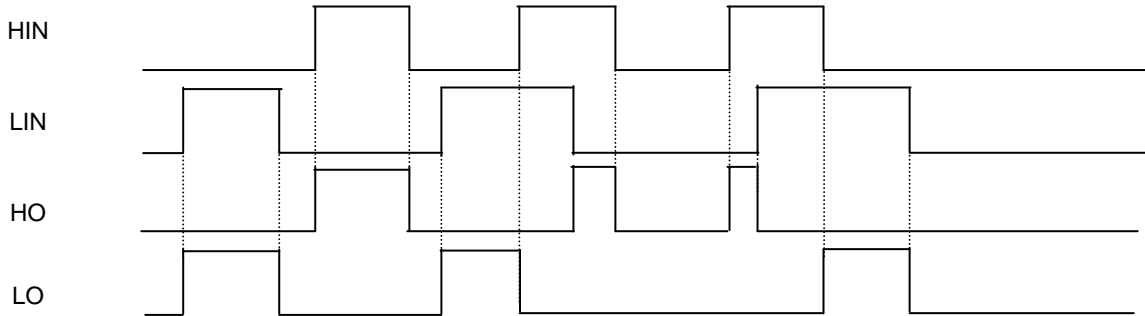

2. V_{CC} (V_{BS}) Supply Under Voltage Lockout Timing Diagram

If V_{CC} Supply voltage drops below UV trip voltage ($V_{CCuvt} = V_{CCuvr} - V_{CCuvh}$) for V_{CC} supply UV filter time, output signal LO becomes "L". As soon as V_{CC} supply voltage rises over UV reset voltage, output signal LO becomes "H" if input signal is "H".

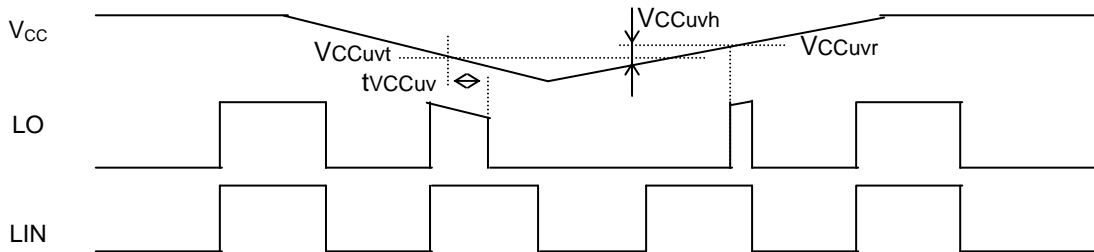

If V_{CC} Supply voltage drops below UV trip voltage ($V_{CCuvt} = V_{CCuvr} - V_{CCuvh}$) for V_{CC} supply UV filter time, output signal HO becomes "L". As soon as V_{CC} supply voltage rises over UV reset voltage, output signal HO becomes "H" if input signal is "H".

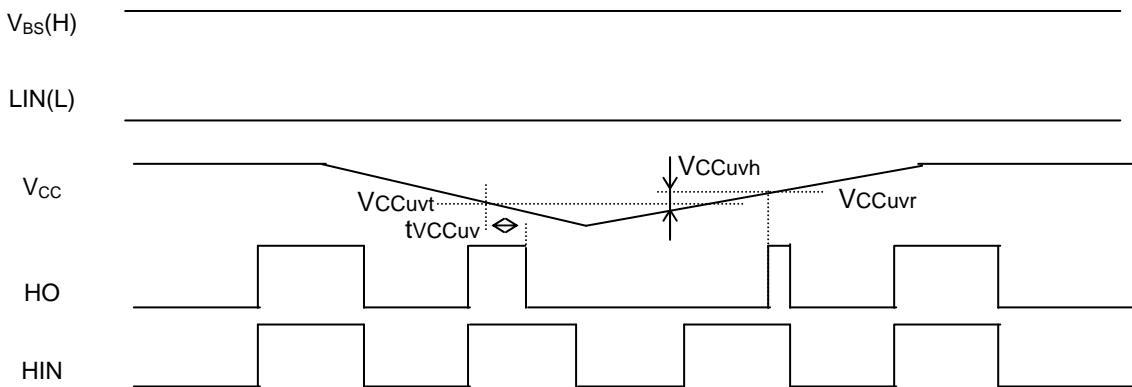

If V_{BS} Supply voltage drops below UV trip voltage ($V_{BSuvt} = V_{BSuvr} - V_{BSuvh}$) for V_{BS} supply UV filter time, output signal HO becomes "L". As soon as V_{BS} supply voltage rises over UV reset voltage, output signal HO becomes "H" at following "H" edge of input signal.

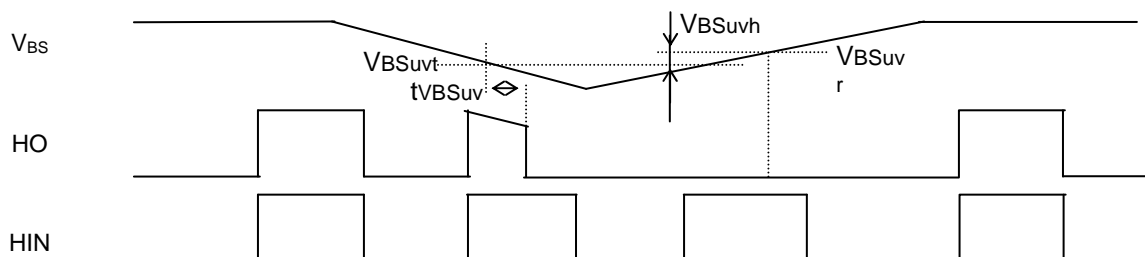

<HVIC>

M81729JFP

HIGH VOLTAGE HALF BRIDGE DRIVER FOR AUTOMOTIVE APPLICATIONS

3. NOTES

1) Allowable supply voltage transient

It is recommended to supply V_{CC} firstly and supply V_{BS} secondly. In the case of shutting off supply voltage, please shut off V_{BS} firstly and shut off V_{CC} secondly. When applying V_{CC} and V_{BS} , power supply should be applied slowly. If it rises rapidly, output signal (HO or LO) may be malfunction.

2) Supply voltage start up or restart after shut down

If V_{CC} supply is less than 10V(outside of RECOMMENDED OPERATING CONDITIONS), there is some possibility that output does not change in response to input. Please evaluate carefully about supply start up or restart after shut down in your application systems.

3) V_B supply voltage

Please use V_B supply voltage within RECOMMENDED OPERATING CONDITIONS ($V_S+10V < V_B < V_S +20V : V_S \text{ Min} = 0V$). When V_B supply voltage is used on the other conditions, output signal HO may be malfunction. Please evaluate carefully about V_B supply voltage in your application systems.

4) dV/dt of V_S supply voltage

Please rises or falls V_S supply voltage by less than $6KV/\mu s$. If it rises or falls rapidly, output signal HO may be malfunction.

5) Narrow pulse input dead time of HIN and LIN

Please set up "H" input dead time of HIN and LIN more than 300ns.

6) Processing between IC terminals

As for this product, the terminal of low voltage part and high voltage part is very clear (The Fifth: LO, The Sixth: V_S). Therefore, pin insulation space distance should be taken enough.

PACKAGE OUTLINE

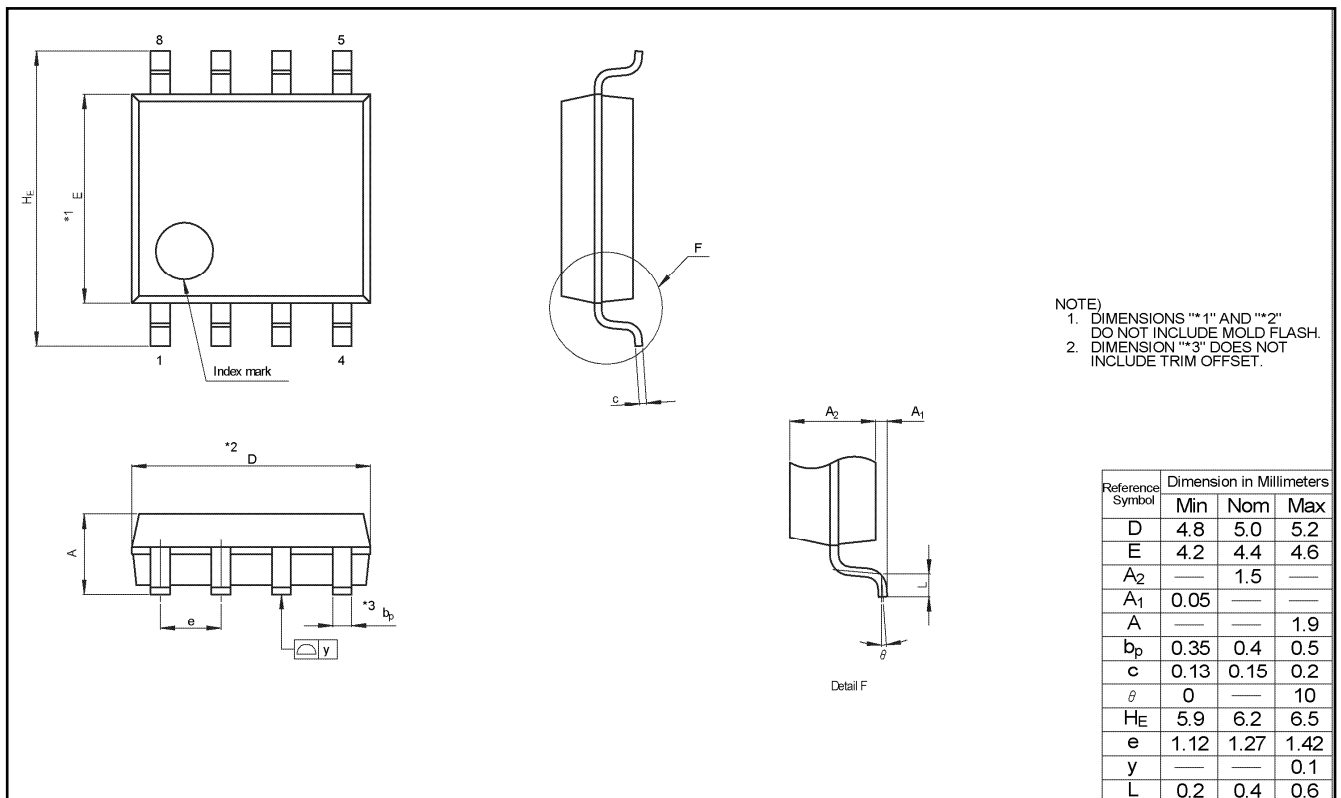

<HVIC>

M81729JFP

HIGH VOLTAGE HALF BRIDGE DRIVER FOR AUTOMOTIVE APPLICATIONS

Main Revision for this Edition

No.	Date	Revision	
		Pages	Points
A	2012.03.27	-	New

Keep safety first in your circuit designs!

Mitsubishi Electric Corporation puts the maximum effort into making semiconductor products better and more reliable, but there is always the possibility that trouble may occur with them. Trouble with semiconductors may lead to personal injury, fire or property damage. Remember to give due consideration to safety when making your circuit designs, with appropriate measures such as (i) placement of substitutive, auxiliary circuits, (ii) use of non-flammable material or (iii) prevention against any malfunction or mishap.

Notes regarding these materials

- These materials are intended as a reference to assist our customers in the selection of the Mitsubishi semiconductor product best suited to the customer's application; they do not convey any license under any intellectual property rights, or any other rights, belonging to Mitsubishi Electric Corporation or a third party.
- Mitsubishi Electric Corporation assumes no responsibility for any damage, or infringement of any third-party's rights, originating in the use of any product data, diagrams, charts, programs, algorithms, or circuit application examples contained in these materials.
- All information contained in these materials, including product data, diagrams, charts, programs and algorithms represents information on products at the time of publication of these materials, and are subject to change by Mitsubishi Electric Corporation without notice due to product improvements or other reasons. It is therefore recommended that customers contact Mitsubishi Electric Corporation or an authorized Mitsubishi Semiconductor product distributor for the latest product information before purchasing a product listed herein.

The information described here may contain technical inaccuracies or typographical errors. Mitsubishi Electric Corporation assumes no responsibility for any damage, liability, or other loss rising from these inaccuracies or errors.

Please also pay attention to information published by Mitsubishi Electric Corporation by various means, including the Mitsubishi Semiconductor home page (<http://www.MitsubishiElectric.com/>).

- When using any or all of the information contained in these materials, including product data, diagrams, charts, programs, and algorithms, please be sure to evaluate all information as a total system before making a final decision on the applicability of the information and products. Mitsubishi Electric Corporation assumes no responsibility for any damage, liability or other loss resulting from the information contained herein.
- Mitsubishi Electric Corporation semiconductors are not designed or manufactured for use in a device or system that is used under circumstances in which human life is potentially at stake. Please contact Mitsubishi Electric Corporation or an authorized Mitsubishi Semiconductor product distributor when considering the use of a product contained herein for any specific purposes, such as apparatus or systems for transportation, vehicular, medical, aerospace, nuclear, or undersea repeater use.
- The prior written approval of Mitsubishi Electric Corporation is necessary to reprint or reproduce in whole or in part these materials.
- If these products or technologies are subject to the Japanese export control restrictions, they must be exported under a license from the Japanese government and cannot be imported into a country other than the approved destination.
Any diversion or re-export contrary to the export control laws and regulations of Japan and/or the country of destination is prohibited.
- Please contact Mitsubishi Electric Corporation or an authorized Mitsubishi Semiconductor product distributor for further details on these materials or the products contained therein.