

M81723FP

HIGH VOLTAGE HALF BRIDGE DRIVER

DESCRIPTION

M81723FP is high voltage Power MOSFET and IGBT module driver for half bridge applications.

FEATURES

- FLOATING SUPPLY VOLTAGE 600V
- OUTPUT CURRENT +130mA/-100mA (typ)
- UNDERVOLTAGE LOCKOUT
- SOP-16 PACKAGE

APPLICATIONS

IGBT/MOSFET driver

PIN CONFIGURATION (TOP VIEW)

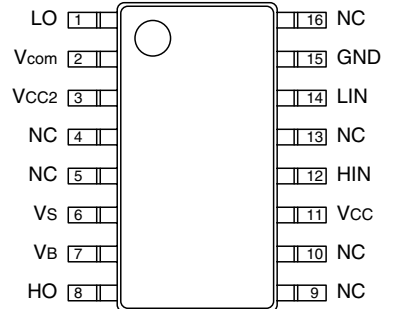

NC:NO CONNECTION

Outline:16P2N

BLOCK DIAGRAM

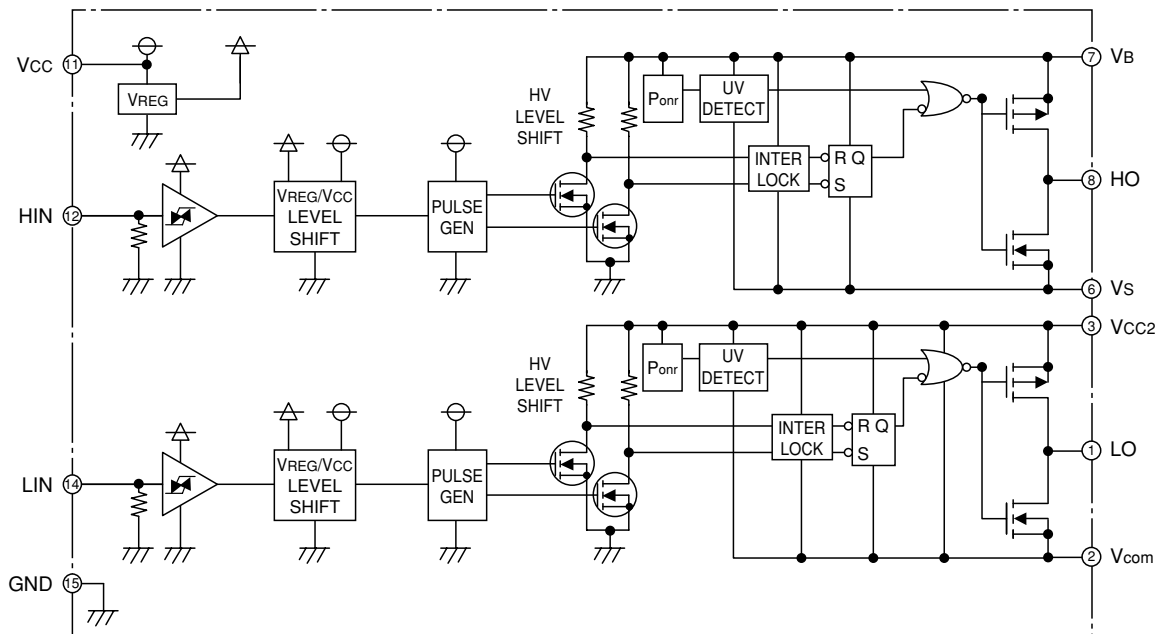

M81723FP

HIGH VOLTAGE HALF BRIDGE DRIVER

ABSOLUTE MAXIMUM RATINGS (Ta = 25°C unless otherwise specified)

Symbol	Parameter	Test conditions	Ratings	Unit
V _B	High Side Floating Supply Absolute Voltage		-0.5 ~ 624	V
V _S	High Side Floating Supply Offset Voltage		V _B -24 ~ V _B +0.5	V
V _{BS}	High Side Floating Supply Voltage	V _{BS} = V _B -V _S	-0.5 ~ 24	V
V _{HO}	High Side Output Voltage		V _S -0.5 ~ V _B +0.5	V
V _{CC2}	Low Side Floating Supply Absolute Voltage		-0.5 ~ 624	V
V _{com}	Output Standard Voltage		V _{CC2} -24 ~ V _{CC2} +0.5	V
V _{CC2com}	Low Side Floating Supply Voltage	V _{CC2com} = V _{CC2} -V _{com}	-0.5 ~ 24	V
V _{LO}	Low Side Output Voltage		V _{com} -0.5 ~ V _{CC2} +0.5	V
V _{CC}	Low Side Fixed Supply Voltage		-0.5 ~ 24	V
V _{IN}	Logic Input Voltage	HIN, LIN	-0.5 ~ V _{CC} +0.5	V
dV _S /dt	Allowable Offset Voltage Transient		±50	V/ns
P _d	Package Power Dissipation	Ta = 25°C, On Board	0.11	W
K _θ	Linear Derating Factor	Ta > 25°C, On Board	-8.9	mW/°C
R _{th(j-c)}	Junction-Case Thermal Resistance		45	°C/W
T _j	Junction Temperature		-40 ~ 125*	°C
T _{opr}	Operation Temperature		-40 ~ 100	°C
T _{stg}	Storage Temperature		-55 ~ 150	°C
TL	Solder Heat-proof (Reflow)	Pb Free	255:10s, max 260	°C

* Please adjust the V_S potential to 500V or less when the junction temperature (T_j) exceeds 125°C.

RECOMMENDED OPERATING CONDITIONS

Symbol	Parameter	Test conditions	Limits			Unit
			Min.	Typ.	Max.	
V _B	High Side Floating Supply Absolute Voltage		V _S +10	—	V _S +20	V
V _S	High Side Floating Supply Offset Voltage	V _B > 10V	-5	—	500	V
V _{BS}	High Side Floating Supply Voltage	V _{BS} = V _B -V _S	10	—	20	V
V _{HO}	High Side Output Voltage		V _S	—	V _B	V
V _{CC2}	Low Side Floating Supply Absolute Voltage		V _{com} +10	—	V _{com} +20	V
V _{com}	Output Standard Voltage	V _{CC2} > 10V	-5	—	500	V
V _{CC2com}	Low Side Floating Supply Voltage	V _{CC2com} = V _{CC2} -V _{com}	10	—	20	V
V _{LO}	Low Side Output Voltage		V _{com}	—	V _{CC2}	V
V _{CC}	Low Side Fixed Supply Voltage		10	—	20	V
V _{IN}	Logic Input Voltage	HIN, LIN	0	—	V _{CC}	V

* For proper operation, the device should be used within the recommended conditions.

THERMAL DERATING FACTOR CHARACTERISTIC (MAXIMUM RATING)

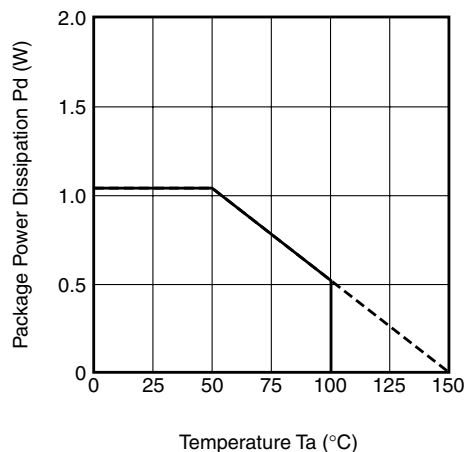

ELECTRICAL CHARACTERISTICS (Ta = 25°C, Vcc = Vcc2com (= Vcc2-Vcom) = Vbs (= Vb-Vs) = 15V, Vs = Vcom = 0V, unless otherwise specified)

Symbol	Parameter	Test conditions	Limits			Unit
			Min.	Typ.*	Max.	
IFS	Floating Supply Leakage Current	Vb = Vs = 600V	—	—	1.0	μA
IFcom	Vcom Floating Supply Leakage Current	Vcc2 = Vcom = 600V	—	—	1.0	μA
IBS	Vbs Standby Current	HIN = LIN = 0V	—	0.20	0.4	mA
ICC	Vcc Standby Current	HIN = LIN = 0V	—	0.30	0.6	mA
ICC2	Vcc2 Standby Current	HIN = LIN = 0V	—	0.20	0.4	mA
IBSH	Vbs Standby Current H	HIN = 5V	—	0.25	0.5	mA
ICCH	Vcc Standby Current H	HIN = 5V	—	0.37	0.75	mA
ICC2H	Vcc2 Standby Current H	HIN = 5V	—	0.20	0.4	mA
IBSL	Vbs Standby Current L	LIN = 5V	—	0.20	0.4	mA
ICCL	Vcc Standby Current L	LIN = 5V	—	0.37	0.75	mA
ICC2L	Vcc2 Standby Current L	LIN = 5V	—	0.25	0.5	mA
VOH	High Level Output Voltage	Io = 0A, LO, HO	14.9	—	—	V
VOL	Low Level Output Voltage	Io = 0A, LO, HO	—	—	0.1	V
VIH	High Level Input Threshold Voltage	HIN, LIN	4.0	—	—	V
VIL	Low Level Input Threshold Voltage	HIN, LIN	—	—	0.6	V
VINh	Input Hysteresis Voltage	VINh = VIH-VIL	1.0	1.5	2.0	V
IiH5	High Level Input Bias Current 5	VIN = 5V	—	25	75	μA
IiH15	High Level Input Bias Current 15	VIN = 15V	—	75	150	μA
IiL	Low Level Input Bias Current	VIN = 0V	—	—	1.0	μA
VBSuvr	Vbs Supply UV Reset Voltage		7.2	8.4	9.7	V
VBSuvh	Vbs Supply UV Hysteresis Voltage		0.1	0.4	0.7	V
tVBSuv	Vbs Supply UV Filter Time		—	7.5	—	μs
VCC2uvr	Vcc2 Supply UV Reset Voltage		7.2	8.4	9.7	V
VCC2uvh	Vcc2 Supply UV Hysteresis Voltage		0.1	0.4	0.7	V
tVCC2ur	Vcc2 Supply UV Filter Time		—	7.5	—	μs
VPonr	Power-On Reset Voltage		—	—	6.0	V
tPonr(FIL)	Power-On Reset Filter Time		300	—	—	ns
IOH	Output High Level Short Circuit Pulsed Current	Vo = 0V, VIN = 5V, PW < 10μs	80	130	180	mA
IOL	Output Low Level Short Circuit Pulsed Current	Vo = 15V, VIN = 0V, PW < 10μs	60	100	140	mA
ROH	Output High Level On Resistance	Io = -20mA, ROH = (VOH-Vo)/Io	—	55	100	Ω
ROL	Output Low Level On Resistance	Io = 20mA, ROL = Vo/Io	—	45	70	Ω
tdLH(HO)	High Side Turn-On Propagation Delay	CL = 200pF between HO-Vs	75	95	120	ns
tdHL(HO)	High Side Turn-Off Propagation Delay	CL = 200pF between HO-Vs	85	115	145	ns
trH	High Side Turn-On Rise Time	CL = 200pF between HO-Vs	15	35	70	ns
tfH	High Side Turn-Off Fall Time	CL = 200pF between HO-Vs	10	30	80	ns
tdLH(LO)	Low Side Turn-On Propagation Delay	CL = 200pF between LO-Vcom	70	95	120	ns
tdHL(LO)	Low Side Turn-Off Propagation Delay	CL = 200pF between LO-Vcom	85	115	145	ns
trL	Low Side Turn-On Rise Time	CL = 200pF between LO-Vcom	15	35	70	ns
tfL	Low Side Turn-Off Fall Time	CL = 200pF between LO-Vcom	10	30	80	ns
ΔtdLH	Delay Matching, High Side and Low Side Turn-On	tdLH(HO)-tdLH(LO)	—	—	15	ns
ΔtdHL	Delay Matching, High Side and Low Side Turn-Off	tdHL(HO)-tdHL(LO)	—	—	15	ns
VOPW	Output Pulse Width	VIN : PW = 200ns	200	220	240	ns

* Typ. is not specified.

FUNCTION TABLE

HIN	LIN	VBS UV	VCC2com UV	HO	LO	Behavioral state
H→L	H→L	H	H	L	L	LO = HO = Low
H→L	L→H	H	H	L	H	LO = High
L→H	H→L	H	H	H	L	HO = High
L→H	L→H	H	H	H	H	LO = HO = High
X	H→L	L	H	L	L	HO = Low, VBS UV tripped
X	L→H	L	H	L	H	LO = High, VBS UV tripped
H→L	X	H	L	L	L	LO = Low, VCC2com UV tripped
L→H	X	H	L	H	L	HO = High, VCC2com UV tripped

Note1 : "L" state of Vbs UV, Vcc UV means that UV trip voltage.

2 : In the case of both input signals (HIN and LIN) are "H", output signals (HO and LO) become "H".

3 : X : L→H or H→L.

4 : Output signal (HO, LO) is triggered by the edge of input signal.

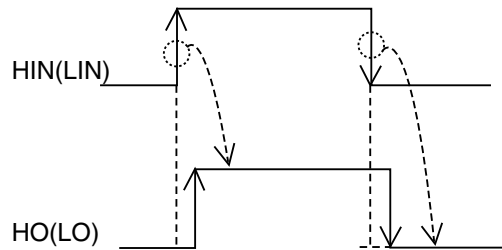

TIMING DIAGRAM

1. Input/Output Timing Diagram

HIGH ACTIVE (When input signal (HIN or LIN) is "H", then output signal (HO or LO) is "H".)

In the case of both input signals (HIN and LIN) are "H", output signals (HO and LO) become "H".

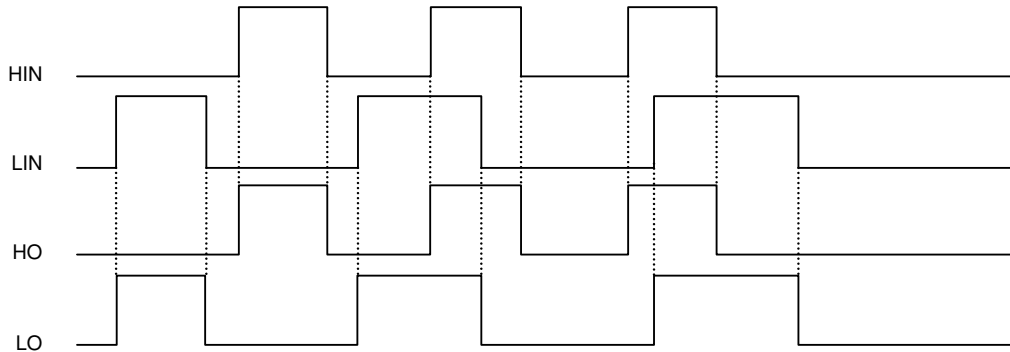

2. VCC2com (VBS) Supply Under Voltage Lockout Timing Diagram

If supply voltage drops below UV trip voltage (** v_{uvt} = ** v_{uvr} - ** v_{uvh}) for supply UV filter time, output signal becomes "L". As soon as supply voltage is higher than UV reset voltage, output becomes normal.

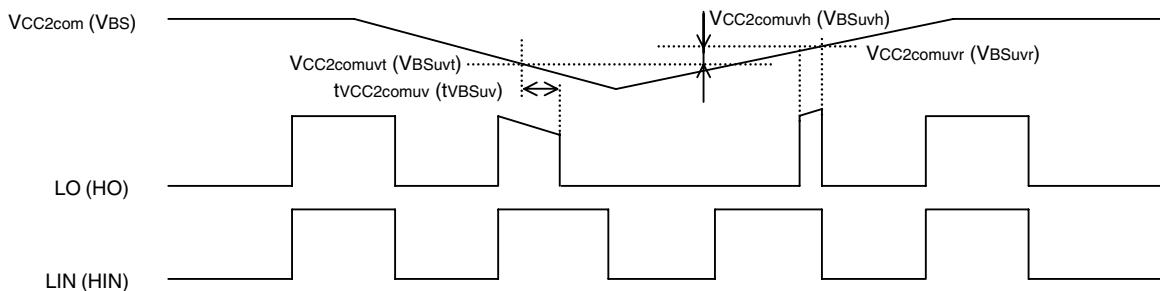

M81723FP

HIGH VOLTAGE HALF BRIDGE DRIVER

3. Allowable Supply Voltage Transient

It is recommended to supply VCC firstly and supply VCC2com secondly and supply VBS at last. In the case of shutting off supply voltage, please shut off VBS supply voltage firstly. Secondly, shut off VCC2com Supply Voltage. And at last, shutting off VCC supply voltage.

When applying VCC2com and VBS, power supply should be applied slowly. If it rises rapidly, output signal (HO or LO) may be malfunction.

PACKAGE OUTLINE

