

<TRANSISTOR ARRAY>

M54522FP

8-UNIT 400mA DARLINGTON TRANSISTOR ARRAY WITH CLAMP DIODE SINK TYPE

DESCRIPTION

M54522FP is an eight-circuit Darlington transistor arrays with clamping diodes. The circuits are made of NPN transistors. Both the semiconductor integrated circuits perform high-current driving with extremely low input-current supply.

FEATURES

- High breakdown voltage ($BV_{CEO} \geq 40V$)
- High-current driving ($I_{c(max)} = 400mA$)
- With clamping diodes
- Driving available with PMOS IC output

APPLICATIONS

Drives of relays and printers, digit drives of indication elements (LEDs and lamps), and interfaces between microcomputer output and high-current or high-voltage systems

FUNCTION

The M54522FP each have eight circuits consisting of NPN Darlington transistors. This ICs have resistance of 20k Ω between input transistor bases and input pins.

A spike-killer clamping diode is provided between each output pin (collector) and COM pin. The output transistor emitters are all connected to the GND pin (pin 10).

The collector current is 400mA maximum. Collector-emitter supply voltage is 40V maximum.

PIN CONFIGURATION

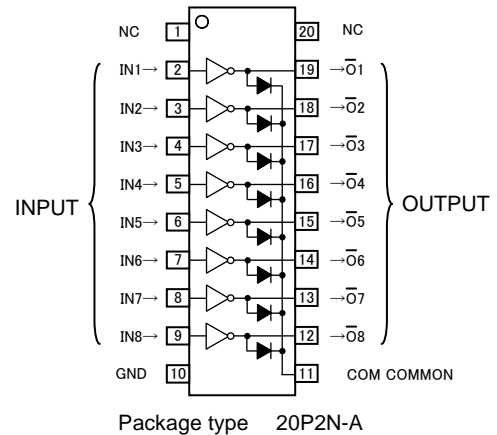

CIRCUIT DIAGRAM

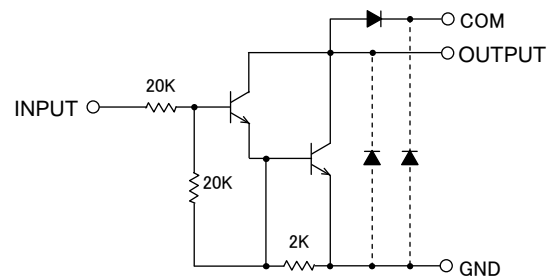

The eight circuits share the COM and GND.

The diode, indicated with the dotted line, is parasitic, and cannot be used.

Unit : Ω

ABSOLUTE MAXIMUM RATINGS (Unless otherwise noted, $T_a = -20 \sim +75^\circ C$)

Symbol	Parameter	Conditions	Ratings	Unit
V_{CEO}	Collector-emitter voltage	Output , H	-0.5 ~ +40	V
I_C	Output current	Current per circuit output, L	400	mA
V_i	Input voltage		-0.5 ~ +40	V
I_F	Clamping diode forward current		400	mA
V_R	Clamping diode reverse voltage		40	V
P_d	Power dissipation	$T_a = 25^\circ C$, when mounted on board	1.10	W
T_{opr}	Operating temperature		-20 ~ +75	$^\circ C$
T_{stg}	Storage temperature		-55 ~ +125	$^\circ C$

<TRANSISTOR ARRAY>

M54522FP

8-UNIT 400mA DARLINGTON TRANSISTOR ARRAY WITH CLAMP DIODE SINK TYPE

RECOMMENDED OPERATING (Unless otherwise noted, Ta = -20 ~ +75°C)

Symbol	Parameter		Limits			Unit
			min	typ	max	
V _o	Output voltage		0	—	40	V
I _c	Collector current (Current per 1 circuit when 8 circuits are coming on simultaneously)	Duty Cycle no more than 5%	0	—	400	mA
		Duty Cycle no more than 20%	0	—	200	
V _{IH}	“H” input voltage	I _c ≤ 400mA	8	—	30	V
		I _c ≤ 200mA	4	—		
V _{IL}	“L” input voltage		0	—	0.5	V

ELECTRICAL CHARACTERISTICS (Unless otherwise noted, Ta = -20~+75°C)

Symbol	Parameter	Test conditions	Limits			Unit
			min	typ *	max	
V _{(BR)CEO}	Collector-emitter breakdown voltage	I _{CEO} = 100 μA	40	—	—	V
V _{CE(sat)}	Collector-emitter saturation voltage	V _I = 8V, I _c = 400mA	—	1.15	2.4	V
		V _I = 4V, I _c = 200mA	—	0.95	1.6	
I _I	Input current	V _I = 17V	0.3	0.85	1.8	mA
V _F	Clamping diode forward voltage	I _F = 400mA	—	1.5	2.4	V
I _R	Clamping diode reverse current	V _R = 40V	—	—	100	μA
h _{FE}	DC amplification factor	V _{CE} = 4V, I _c = 300mA, Ta = 25°C	1000	8000	—	—

* : The typical values are those measured under ambient temperature (Ta) of 25°C.
There is no guarantee that these values are obtained under any conditions.

SWITCHING CHARACTERISTICS (Unless otherwise noted, Ta = 25°C)

Symbol	Parameter	Test conditions	Limits			Unit
			min	typ	max	
t _{on}	Turn-on time	C _L = 15pF (note 1)	—	30	—	ns
t _{off}	Turn-off time		—	930	—	ns

NOTE 1 TEST CIRCUIT

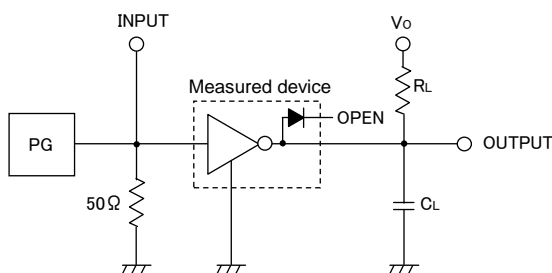

- (1) Pulse generator (PG) characteristics: PRR = 1kHz, t_w = 10 μs, t_r = 6ns, t_f = 6ns, Z_o = 50 Ω, V_{IN} = 0 to 8V
- (2) Input-output conditions : R_L = 25 Ω, V_O = 10V
- (3) Electrostatic capacity C_L includes floating capacitance at connections and input capacitance at probes

TIMING DIAGRAM

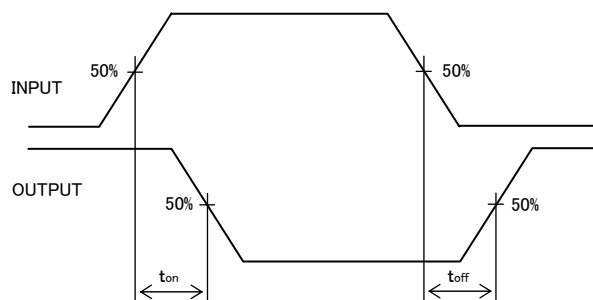

<TRANSISTOR ARRAY>

M54522FP

8-UNIT 400mA DARLINGTON TRANSISTOR ARRAY WITH CLAMP DIODE
SINK TYPE

TYPICAL CHARACTERISTICS

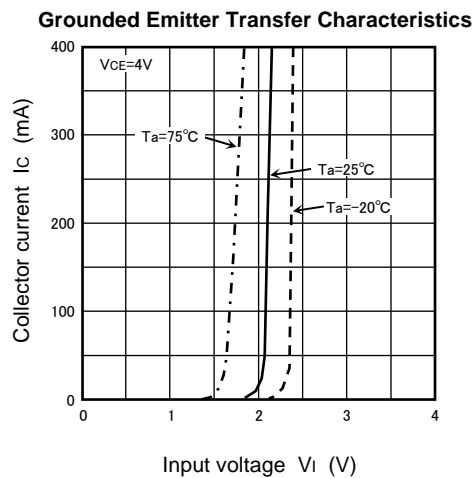
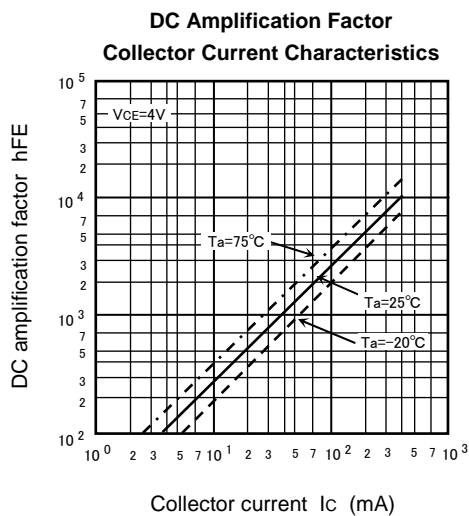
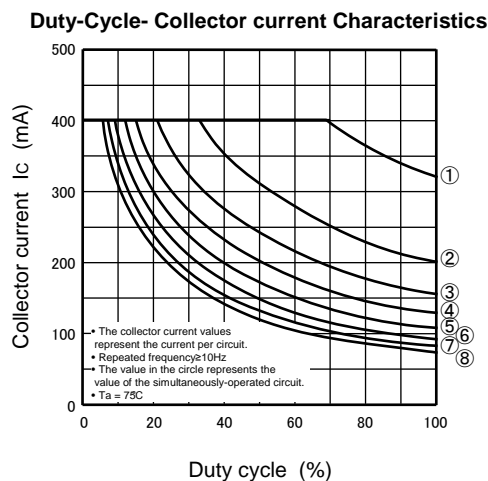
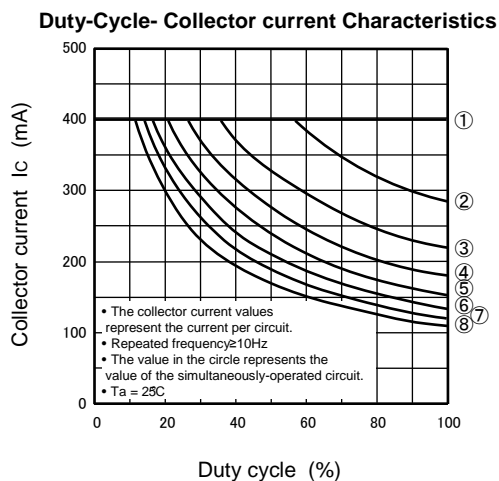
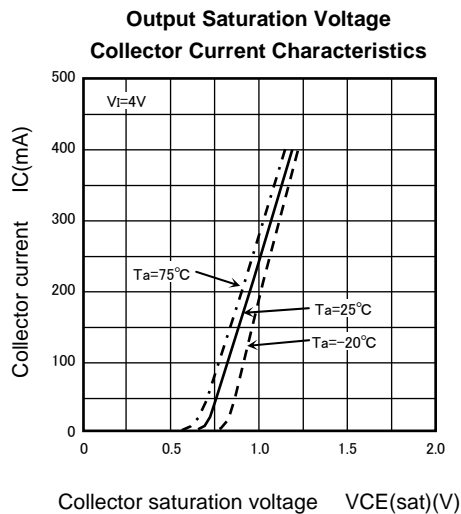
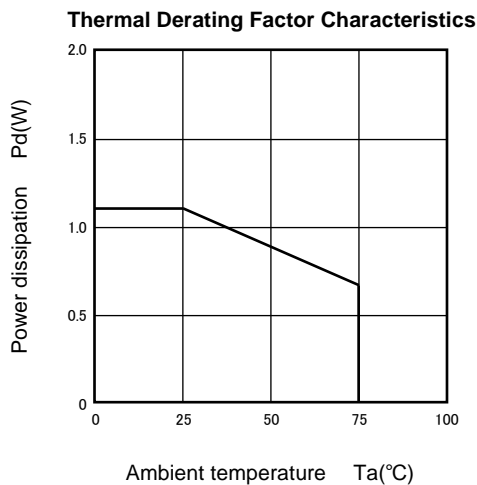

<TRANSISTOR ARRAY>

M54522FP

8-UNIT 400mA DARLINGTON TRANSISTOR ARRAY WITH CLAMP DIODE
SINK TYPE

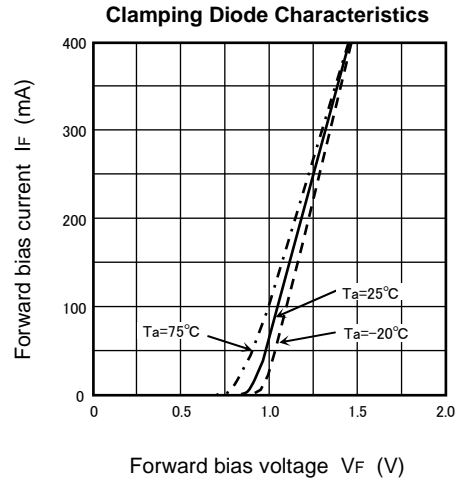
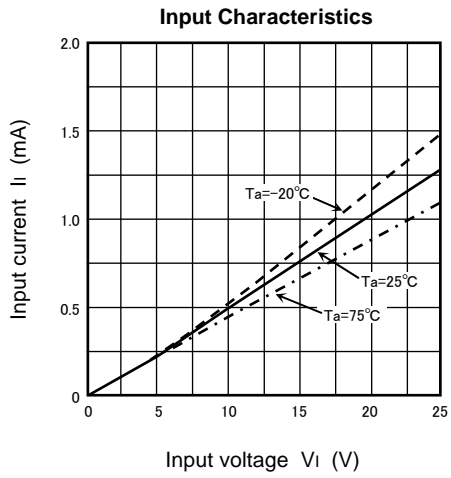

<TRANSISTOR ARRAY>

M54522FP

8-UNIT 400mA DARLINGTON TRANSISTOR ARRAY WITH CLAMP DIODE
SINK TYPE

PACKAGE OUTLINE

20P2N-A

JEITA Package Code	JEDEC Code	Weight(g)	Lead Material
P-SOP20-5.3x12.6-1.27	-	0.26	Cu Alloy

Plastic 20pin 300mil SOP

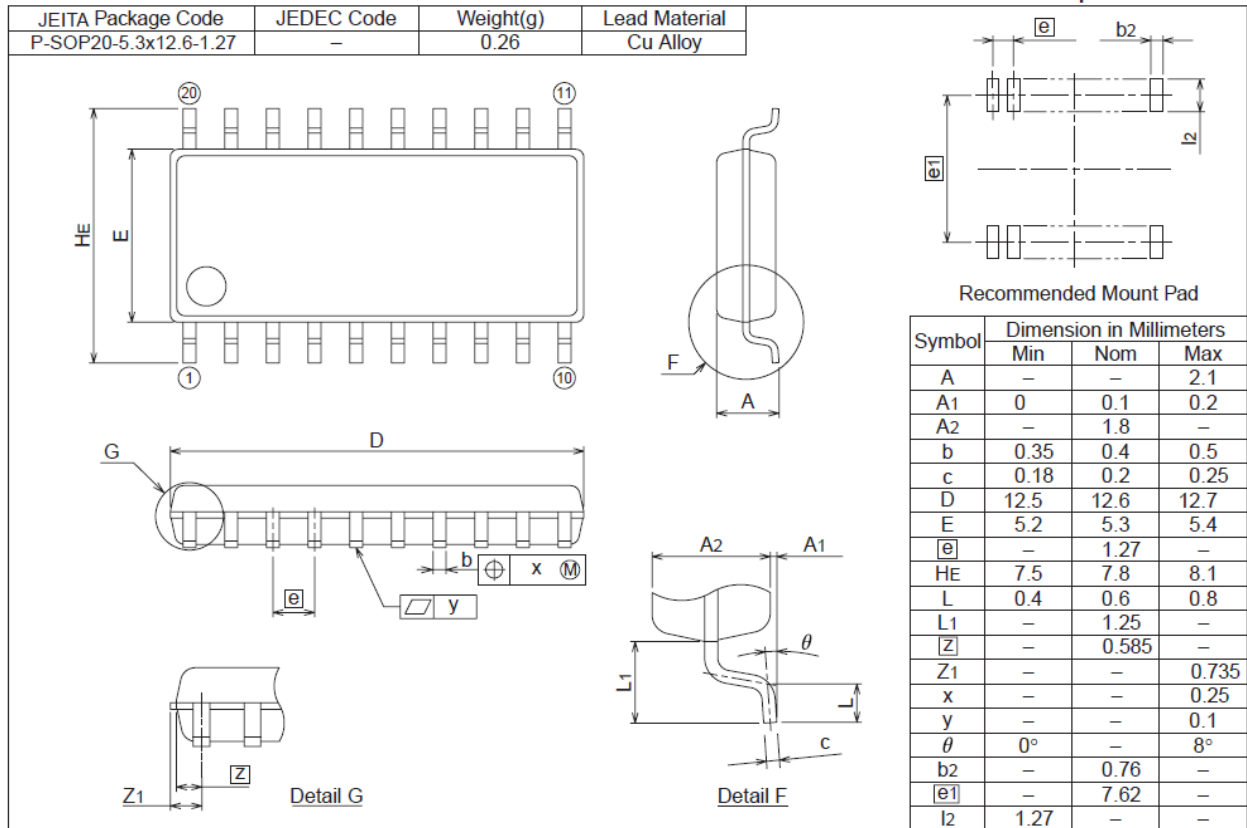

Keep safety first in your circuit designs!

Mitsubishi Electric Corporation puts the maximum effort into making semiconductor products better and more reliable, but there is always the possibility that trouble may occur with them. Trouble with semiconductors may lead to personal injury, fire or property damage. Remember to give due consideration to safety when making your circuit designs, with appropriate measures such as (i) placement of substitutive, auxiliary circuits, (ii) use of non-flammable material or (iii) prevention against any malfunction or mishap.

Notes regarding these materials

- These materials are intended as a reference to assist our customers in the selection of the Mitsubishi semiconductor product best suited to the customer's application; they do not convey any license under any intellectual property rights, or any other rights, belonging to Mitsubishi Electric Corporation or a third party.
- Mitsubishi Electric Corporation assumes no responsibility for any damage, or infringement of any third-party's rights, originating in the use of any product data, diagrams, charts, programs, algorithms, or circuit application examples contained in these materials.
- All information contained in these materials, including product data, diagrams, charts, programs and algorithms represents information on products at the time of publication of these materials, and are subject to change by Mitsubishi Electric Corporation without notice due to product improvements or other reasons. It is therefore recommended that customers contact Mitsubishi Electric Corporation or an authorized Mitsubishi Semiconductor product distributor for the latest product information before purchasing a product listed herein.

The information described here may contain technical inaccuracies or typographical errors. Mitsubishi Electric Corporation assumes no responsibility for any damage, liability, or other loss rising from these inaccuracies or errors.

Please also pay attention to information published by Mitsubishi Electric Corporation by various means, including the Mitsubishi Semiconductor home page (<http://www.MitsubishiElectric.com/>).

- When using any or all of the information contained in these materials, including product data, diagrams, charts, programs, and algorithms, please be sure to evaluate all information as a total system before making a final decision on the applicability of the information and products. Mitsubishi Electric Corporation assumes no responsibility for any damage, liability or other loss resulting from the information contained herein.
- Mitsubishi Electric Corporation semiconductors are not designed or manufactured for use in a device or system that is used under circumstances in which human life is potentially at stake. Please contact Mitsubishi Electric Corporation or an authorized Mitsubishi Semiconductor product distributor when considering the use of a product contained herein for any specific purposes, such as apparatus or systems for transportation, vehicular, medical, aerospace, nuclear, or undersea repeater use.
- The prior written approval of Mitsubishi Electric Corporation is necessary to reprint or reproduce in whole or in part these materials.
- If these products or technologies are subject to the Japanese export control restrictions, they must be exported under a license from the Japanese government and cannot be imported into a country other than the approved destination.
Any diversion or re-export contrary to the export control laws and regulations of Japan and/or the country of destination is prohibited.
- Please contact Mitsubishi Electric Corporation or an authorized Mitsubishi Semiconductor product distributor for further details on these materials or the products contained therein.