

<TRANSISTOR ARRAY>

M54513FP

8-UNIT 50mA TRANSISTOR ARRAY
SINK TYPE

DESCRIPTION

M54513FP are eight-circuit transistor arrays. The circuits are made of NPN transistors. Both the semiconductor integrated circuits perform high-current driving with extremely low input-current supply.

FEATURES

- High breakdown voltage ($BV_{CEO} \geq 40V$)
- Synchronizing current ($I_c(\max) = 50mA$)

APPLICATION

Driving of digit drives of indication elements (LEDs and lamps) with small signals

FUNCTION

The M54513FP each have eight circuits consisting of NPN transistors. These ICs have resistance of $2k\Omega$ at inputs and of $13.6k\Omega$ between the base and emitter. The GND is used in common in each circuit.

The transistors allow synchronous flow of 50mA collector current. A maximum of 40V voltage can be applied between the collector and emitter.

PIN CONFIGURATION

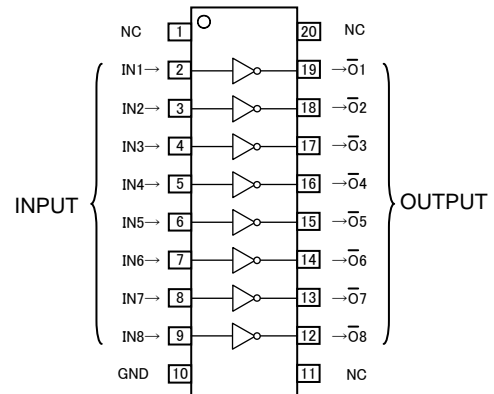

Package type 20P2N-A
NC : No connection

CIRCUIT DIAGRAM

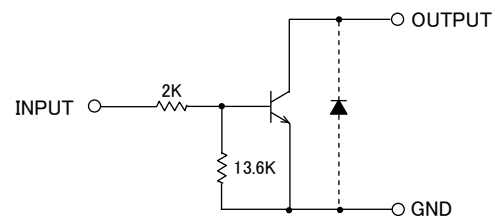

The eight circuits share the GND.
The diode, indicated with the dotted line, is parasitic, and cannot be used.

Unit : Ω

ABSOLUTE MAXIMUM RATINGS (Unless otherwise noted, $T_a = -20 \sim +75\text{ C}$)

Symbol	Parameter	Conditions	Ratings	Unit
V_{CEO}	Collector-emitter voltage	Output, H	-0.5 ~ +40	V
V_i	Input voltage		-0.5 ~ +10	V
I_c	Collector current	Current per circuit output, L	50	mA
P_d	Power dissipation	$T_a = 25\text{ C}$, when mounted on board	1.10	W
T_{opr}	Operating temperature		-20 ~ +75	$^{\circ}\text{C}$
T_{stg}	Storage temperature		-55 ~ +125	$^{\circ}\text{C}$

<TRANSISTOR ARRAY>

M54513FP

8-UNIT 50mA TRANSISTOR ARRAY SINK TYPE

RECOMMENDED OPERATING CONDITIONS (Unless otherwise noted, $T_a = -20 \sim +75 \text{ C}$)

Symbol	Parameter	Limits			Unit
		min	typ	max	
V_o	Output voltage	0	—	40	V
I_c	Collector current	0	—	30	mA
V_{IH}	“H” input voltage	2	—	8	V
V_{IL}	“L” input voltage	0	—	0.2	V

ELECTRICAL CHARACTERISTICS (Unless otherwise noted, $T_a = -20 \sim +75 \text{ C}$)

Symbol	Parameter	Test conditions	Limits			Unit
			min	typ	max	
$V_{(BR)CEO}$	Collector-emitter breakdown voltage	$I_{CEO} = 100 \mu A$	40	—	—	V
$V_{CE(sat)}$	Collector-emitter saturation voltage	$V_i = 2V, I_c = 10mA$	—	25	100	mV
		$V_i = 2.5V, I_c = 30mA$	—	70	170	
I_i	Input current	$V_i = 2.5V$	—	0.85	1.7	mA
h_{FE}	DC amplification factor	$V_{CE} = 4V, I_c = 30mA, T_a = 25^\circ C$	80	200	-	-

*: The typical values are those measured under ambient temperature (T_a) of 25 C. There is no guarantee that these values are obtained under any conditions.

SWITCHING CHARACTERISTICS (Unless otherwise noted, $T_a = -20 \sim +75 \text{ C}$)

Symbol	Parameter	Test conditions	Limits			Unit
			min	typ	max	
t_{on}	Turn-on time	$C_L = 15pF$ (note 1)	—	65	—	ns
t_{off}	Turn-off time		—	1200	—	ns

NOTE 1 TEST CIRCUIT

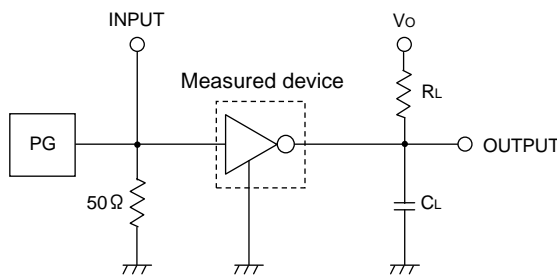

TIMING DIAGRAM

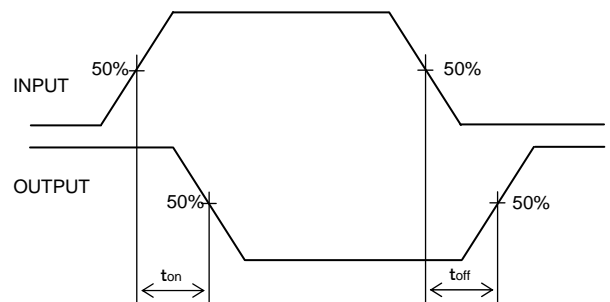

- (1) Pulse generator (PG) characteristics : PRR = 1kHz,
 $t_w = 10 \text{ s}, t_r = 6ns, t_f = 6ns, Z_0 = 50$
 $V_P = 2.5VP-P$
- (2) Output conditions : $R_L = 300 \Omega, V_O = 10V$
- (3) Electrostatic capacity C_L includes floating capacitance at connections and input capacitance at probes

TYPICAL CHARACTERISTICS

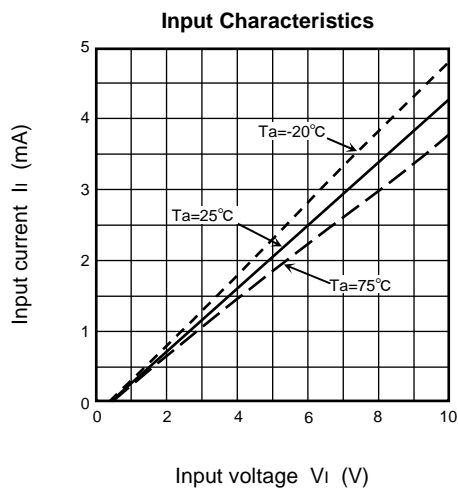
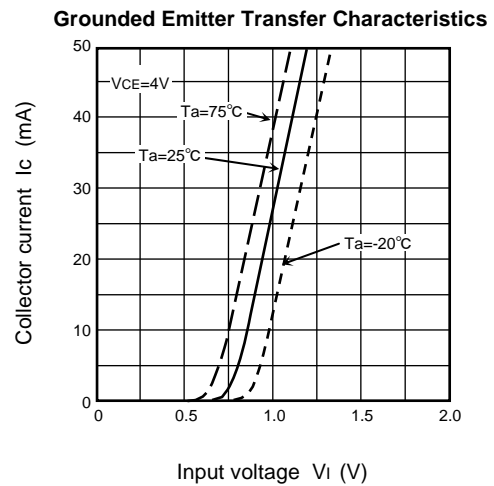
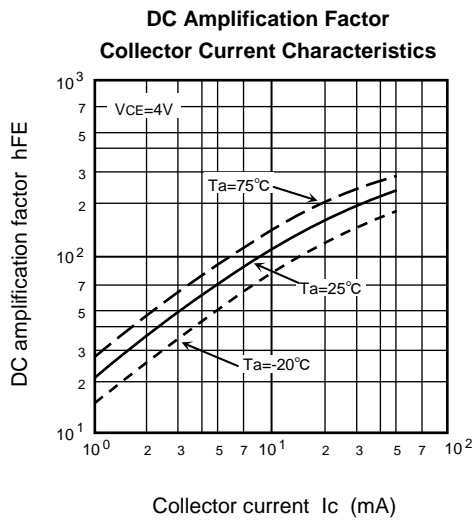
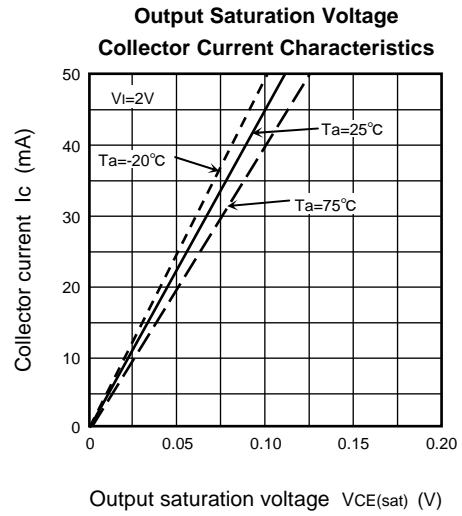
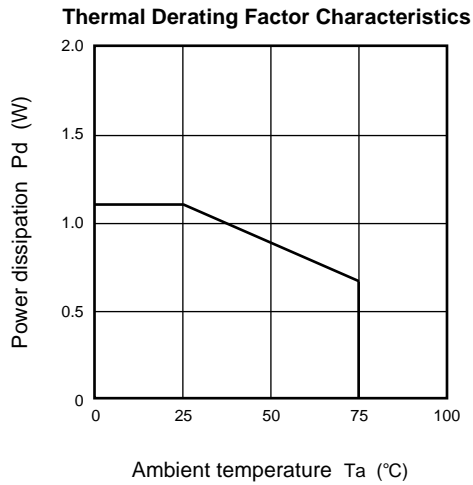

<TRANSISTOR ARRAY>

M54513FP

8-UNIT 50mA TRANSISTOR ARRAY
SINK TYPE

PACKAGE OUTLINE

20P2N-A

JEITA Package Code	JEDEC Code	Weight(g)	Lead Material
P-SOP20-5.3x12.6-1.27	-	0.26	Cu Alloy

Plastic 20pin 300mil SOP

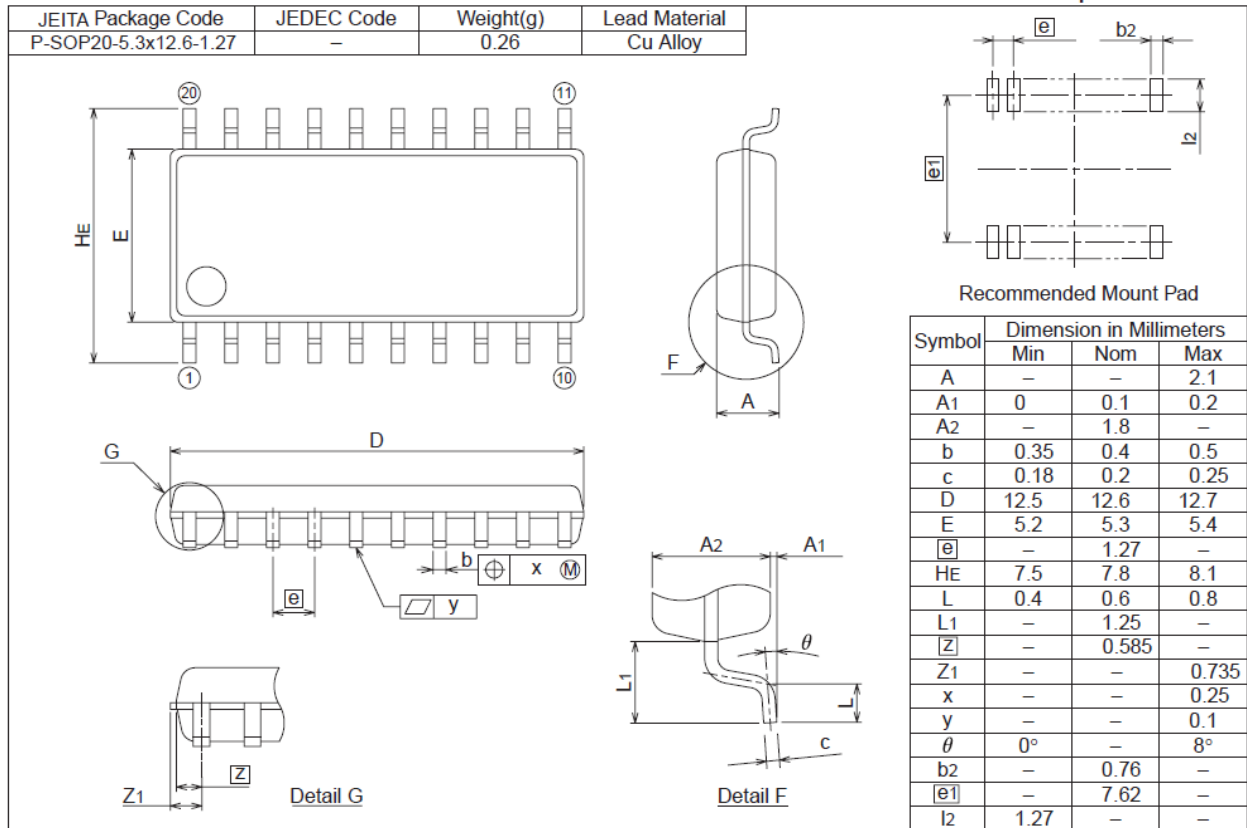

Keep safety first in your circuit designs!

Mitsubishi Electric Corporation puts the maximum effort into making semiconductor products better and more reliable, but there is always the possibility that trouble may occur with them. Trouble with semiconductors may lead to personal injury, fire or property damage. Remember to give due consideration to safety when making your circuit designs, with appropriate measures such as (i) placement of substitutive, auxiliary circuits, (ii) use of non-flammable material or (iii) prevention against any malfunction or mishap.

Notes regarding these materials

- These materials are intended as a reference to assist our customers in the selection of the Mitsubishi semiconductor product best suited to the customer's application; they do not convey any license under any intellectual property rights, or any other rights, belonging to Mitsubishi Electric Corporation or a third party.
- Mitsubishi Electric Corporation assumes no responsibility for any damage, or infringement of any third-party's rights, originating in the use of any product data, diagrams, charts, programs, algorithms, or circuit application examples contained in these materials.
- All information contained in these materials, including product data, diagrams, charts, programs and algorithms represents information on products at the time of publication of these materials, and are subject to change by Mitsubishi Electric Corporation without notice due to product improvements or other reasons. It is therefore recommended that customers contact Mitsubishi Electric Corporation or an authorized Mitsubishi Semiconductor product distributor for the latest product information before purchasing a product listed herein.

The information described here may contain technical inaccuracies or typographical errors. Mitsubishi Electric Corporation assumes no responsibility for any damage, liability, or other loss rising from these inaccuracies or errors.

Please also pay attention to information published by Mitsubishi Electric Corporation by various means, including the Mitsubishi Semiconductor home page (<http://www.MitsubishiElectric.com/>).

- When using any or all of the information contained in these materials, including product data, diagrams, charts, programs, and algorithms, please be sure to evaluate all information as a total system before making a final decision on the applicability of the information and products. Mitsubishi Electric Corporation assumes no responsibility for any damage, liability or other loss resulting from the information contained herein.
- Mitsubishi Electric Corporation semiconductors are not designed or manufactured for use in a device or system that is used under circumstances in which human life is potentially at stake. Please contact Mitsubishi Electric Corporation or an authorized Mitsubishi Semiconductor product distributor when considering the use of a product contained herein for any specific purposes, such as apparatus or systems for transportation, vehicular, medical, aerospace, nuclear, or undersea repeater use.
- The prior written approval of Mitsubishi Electric Corporation is necessary to reprint or reproduce in whole or in part these materials.
- If these products or technologies are subject to the Japanese export control restrictions, they must be exported under a license from the Japanese government and cannot be imported into a country other than the approved destination.
Any diversion or re-export contrary to the export control laws and regulations of Japan and/or the country of destination is prohibited.
- Please contact Mitsubishi Electric Corporation or an authorized Mitsubishi Semiconductor product distributor for further details on these materials or the products contained therein.