

GCU04AA-130

HIGH POWER INVERTER USE
PRESS PACK TYPE

GCU04AA-130

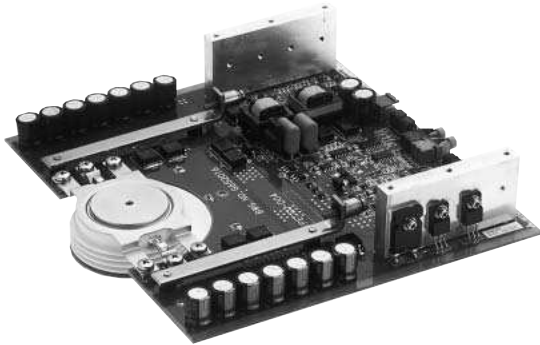

- Symmetrical GCT unit
- GCT and gate driver are connected
- IT(QRM): Repetitive controllable on-state current 400A
- IT(AV): Average on-state current 180A
- VDRM: Repetitive peak off-state voltage 6500V
- VRRM: Repetitive peak reverse voltage 6500V
- T_j: Operation junction temperature 125°C

APPLICATION

Current source inverters, DC choppers, Induction heaters, DC to DC converter

OUTLINE DRAWING

Dimensions in mm

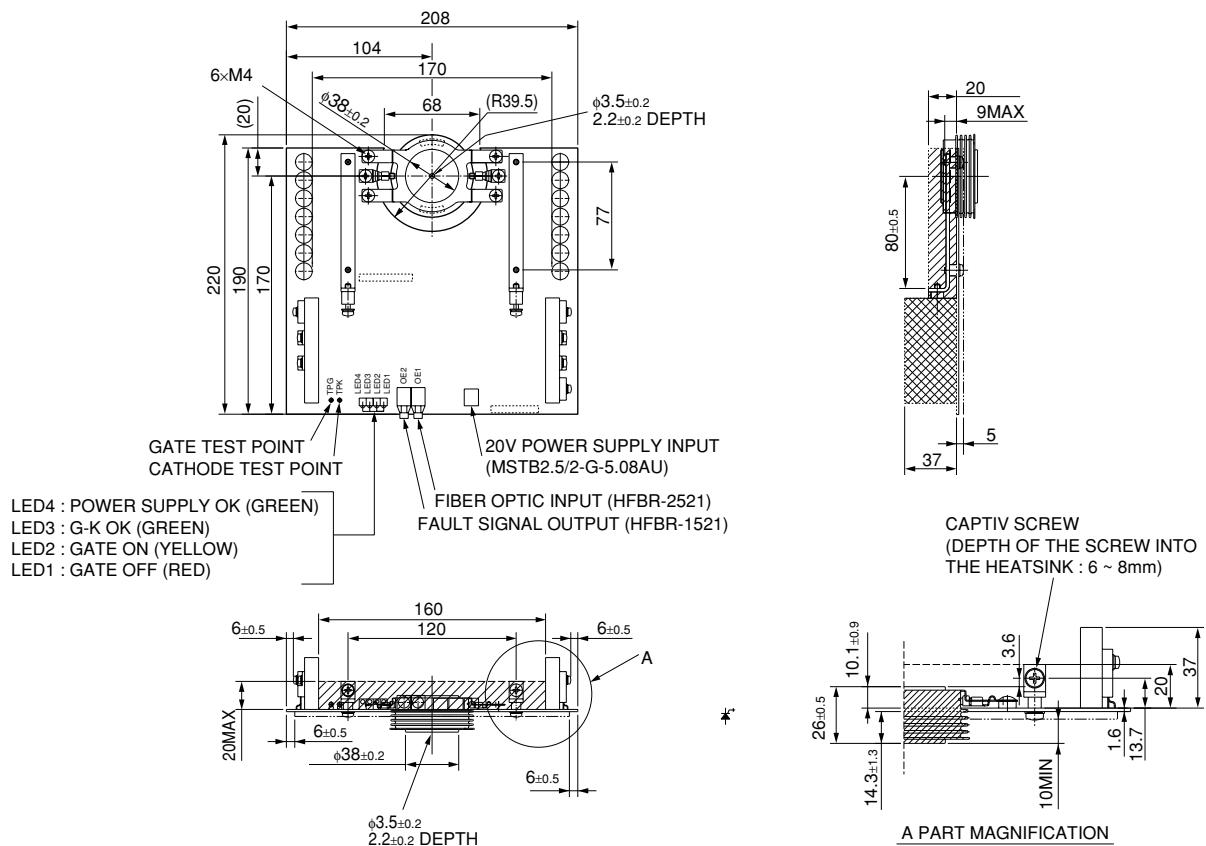

GCU04AA-130

**HIGH POWER INVERTER USE
PRESS PACK TYPE**

GCT PART

MAXIMUM RATINGS

Symbol	Parameter	Conditions	Voltage class	Unit
VRRM	Repetitive peak reverse voltage	—	6500	V
VRSM	Non-repetitive peak reverse voltage	—	6500	V
VDRM	Repetitive peak off-state voltage	Gate driver energized	6500	V
VDSM	Non-repetitive peak off-state voltage	Gate driver energized	6500	V
V(LTDS)	Long term DC stability voltage	Gate driver energized, $\lambda = 100$ Fit	3600	V

Symbol	Parameter	Conditions	Ratings	Unit
IT(RMS)	RMS on-state current	Applied for all condition angles	280	A
IT(AV)	Average on-state current	$f = 60\text{Hz}$, sinewave $\theta = 180^\circ$, $T_f = 55^\circ\text{C}$	180	A
ITQRM	Repetitive controllable on-state current	$V_{DM} = 4000\text{V}$, $V_D = 3000\text{V}$, $L_c = 0.3\mu\text{H}$ $T_j = 25/125^\circ\text{C}$ (See Fig. 1, 3)	400	A
ITSM	Surge on-state current	One half cycle at 60Hz, $T_j = 125^\circ\text{C}$ start	2.8	kA
I^2t	Current-squared, time integration		3.3×10^4	A^2s
diT/dt	Critical rate of rise of on-state current	$V_D = 3000\text{V}$, $I_T = 400\text{A}$, $C_s = 0.06\mu\text{F}$, $R_s = 15\Omega$ $T_j = 25/125^\circ\text{C}$, $f = 60\text{Hz}$ (See Fig. 1, 2)	1000	$\text{A}/\mu\text{s}$
diR/dt	Critical rate of rise of reverse recovery current	$I_T = 400\text{A}$, $V_R = 3000\text{V}$, $T_j = 25/125^\circ\text{C}$ $C_s = 0.06\mu\text{F}$, $R_s = 15\Omega$ (See Fig. 4, 5)	1000	$\text{A}/\mu\text{s}$
PFGM	Peak forward gate power dissipation		3	kW
PRGM	Peak reverse gate power dissipation		9	kW
PFG(AV)	Average forward gate power dissipation		50	W
PRG(AV)	Average reverse gate power dissipation		60	W
VFGM	Peak forward gate voltage		10	V
VRGM	Peak reverse gate voltage		21	V
IFGM	Peak forward gate current		250	A
IRGM	Peak reverse gate current		400	A

ELECTRICAL CHARACTERISTICS

Symbol	Parameter	Conditions	Limits			Unit
			Min	Typ	Max	
V _{TM}	On-state voltage	$I_T = 400\text{A}$, $T_j = 125^\circ\text{C}$	—	—	7.5	V
I _{RRM}	Repetitive peak reverse current	$V_{RM} = 6500\text{V}$, $T_j = 125^\circ\text{C}$	—	—	150	mA
I _{DRM}	Repetitive peak off-state current	$V_{DM} = 6500\text{V}$, $T_j = 125^\circ\text{C}$, Gate driver energized	—	—	100	mA
I _G RM	Reverse gate current	$V_{RG} = 21\text{V}$, $T_j = 125^\circ\text{C}$	—	—	50	mA
dv/dt	Critical rate of rise of off-state voltage	$V_D = 3000\text{V}$, $T_j = 125^\circ\text{C}$ Gate driver energized (Expo. wave)	3000	—	—	$\text{V}/\mu\text{s}$
t _{gt}	Turn-on time	$I_T = 400\text{A}$, $V_D = 3000\text{V}$, $di/dt = 1000\text{A}/\mu\text{s}$	—	—	5	μs
t _d	Turn-on delay time	$C_s = 0.06\mu\text{F}$, $R_s = 15\Omega$, $T_j = 125^\circ\text{C}$	—	—	1	μs
E _{on}	Turn-on switching energy	(See Fig. 1, 2)	—	—	0.7	J/P
t _s	Storage time	$I_T = 400\text{A}$, $V_{DM} = 4000\text{V}$, $V_D = 3000\text{V}$	—	—	3	μs
E _{off}	Turn-off switching energy	$C_s = 0.06\mu\text{F}$, $R_s = 15\Omega$, $T_j = 125^\circ\text{C}$ (See Fig. 1, 5)	—	—	2.9	J/P
Q _{RR}	Reverse recovery charge	$V_R = 3000\text{V}$, $I_T = 400\text{A}$, $di/dt = 1000\text{A}/\mu\text{s}$	—	—	1600	μC
E _{rec}	Reverse recovery energy	$C_s = 0.06\mu\text{F}$, $R_s = 15\Omega$, $T_j = 125^\circ\text{C}$ (See Fig. 4, 5)	—	—	4.1	J/P
I _{GT}	Gate trigger current	$V_D = 24\text{V}$, $R_L = 0.1\Omega$, $T_j = 25^\circ\text{C}$	—	—	0.35	A
V _{GT}	Gate trigger voltage	DC method	—	—	1.5	V

GCU04AA-130

HIGH POWER INVERTER USE
PRESS PACK TYPE

GATE DRIVER PART

Symbol	Parameter	Conditions	Limits			Unit
			Min	Typ	Max	
V _{GIN}	Power supply voltage	DC power supply	19	20	21	V
P _{GIN}	Gate power consumption	I _T = 230Arms, f = 780Hz, duty = 0.33	—	—	20	W
t _{fd}	Delay time of on gate current	T _a = 25°C	—	—	3.0	μs
t _{rd}	Delay time of off gate current	T _a = 25°C	—	—	3.0	μs
—	Control signal	Optical fiber data link Transmitter : HFBR-1521 : Agilent Receiver : HFBR-2521 : Agilent	—	—	—	—
—	Power supply connector	Phoenix contact Type name : MSTB2.5/2-G-5.08AU	—	—	—	—
—	Status signal	— (Note 1)	—	—	—	—

MECHANICAL DATA

Symbol	Parameter	Conditions	Limits			Unit
			Min	Typ	Max	
F _M	Mounting force	—	7.3	8.6	11	kN
—	Weight	—	—	700	—	g
—	Pole piece diameter (GTC device)	±0.2mm	—	38	—	mm
—	Housing thickness (GTC device)	±0.5mm	—	26	—	mm

THERMAL DATA

Symbol	Parameter	Conditions	Limits			Unit
			Min	Typ	Max	
T _j	Junction operating temperature	—	-10	—	125	°C
T _{stg}	Storage temperature	—	-10	—	60	°C
T _a	Ambient operation temperature	Recommend : ≤ 40°C	-10	—	60	°C
R _{t(j-f)}	Thermal resistance	Junction to Fin	—	—	0.04	K/W

GCU04AA-130

HIGH POWER INVERTER USE
PRESS PACK TYPE

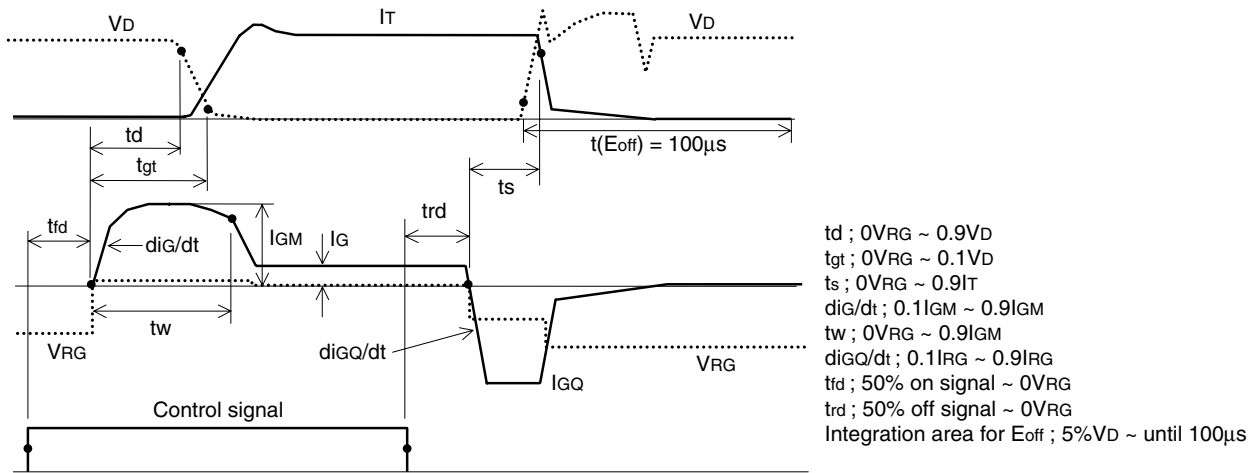

Fig. 1 Turn-on and Turn-off waveform

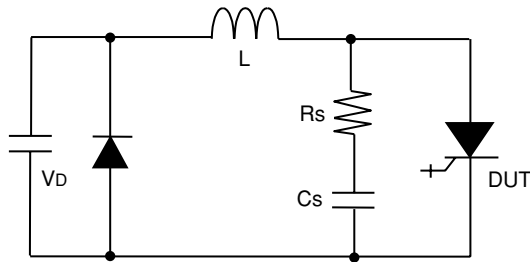

Fig. 2 Turn-on test circuit

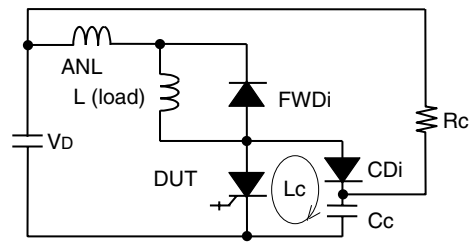

Fig. 3 Turn-off test circuit
(With clamp circuit)

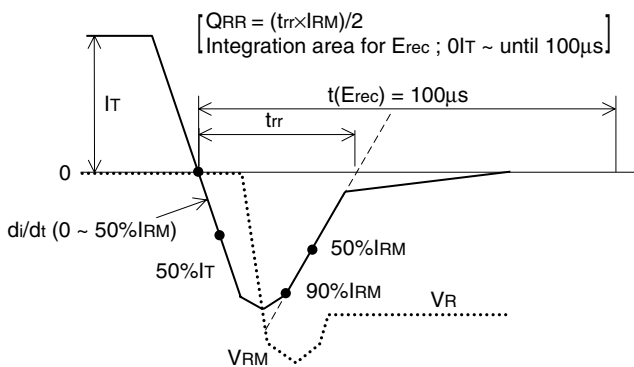

Fig. 4 Reverse recovery waveform

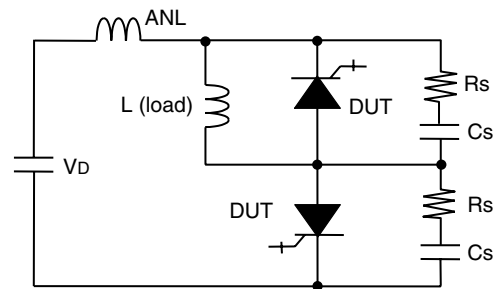

Fig. 5 Turn-off and Reverse recovery test circuit

GCU04AA-130

HIGH POWER INVERTER USE
PRESS PACK TYPE

Note 1. Status signal

1. Status signal from LED

(1) Status signal

Status of GCT	LED 1 (Red)	LED 2 (Yellow)
On state	OFF	ON
Off state	ON	OFF

(2) Fault signal

Status	G-K	Power Supply	G-K LED (LED 3) (Green)	PS LED (LED 4) (Green)
Normal	Normal	20±1V	On	On
Fault	Normal	Voltage down	Off	Off
Fault	G-K short	20±1V	Off	On
Fault	G-K short	Voltage down	Off	Off

2. Status signal from Transmitter

(L : Light NL : No light)

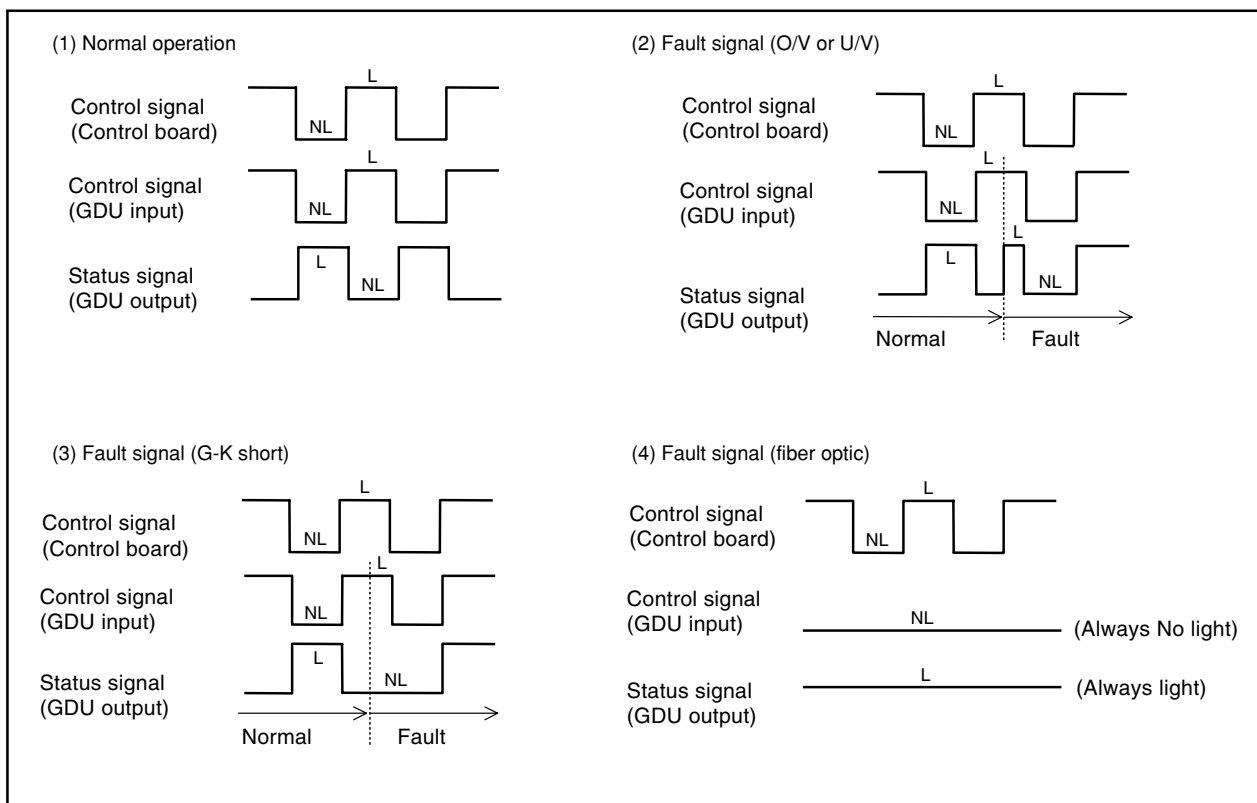

GCU04AA-130

HIGH POWER INVERTER USE
PRESS PACK TYPE

PERFORMANCE CURVES

MAXIMUM ON-STATE CHARACTERISTIC

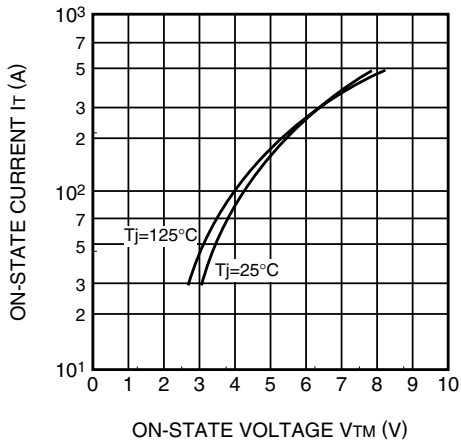

E_{on} VS I_T (Max)

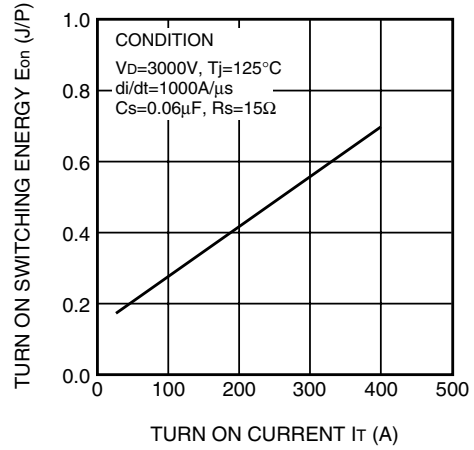

E_{off} VS I_T (Max)

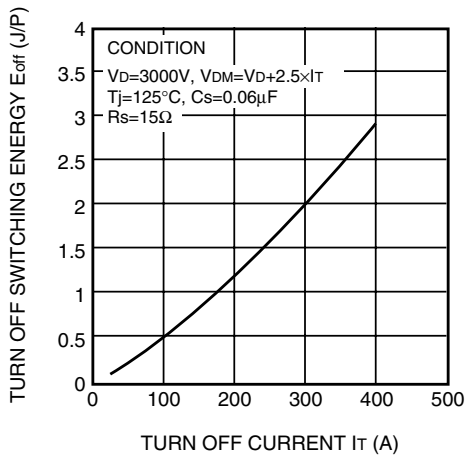

E_{rec} VS I_T (Max)

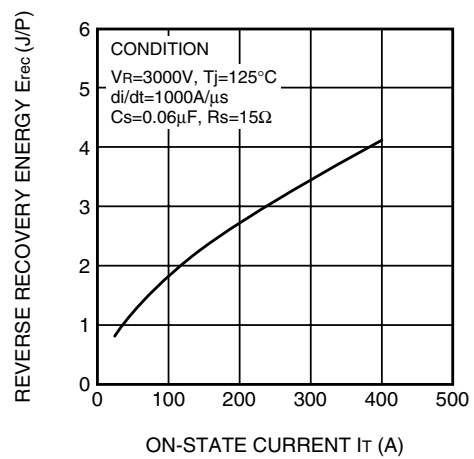

MAXIMUM THERMAL IMPEDANCE CHARACTERISTIC (JUNCTION TO FIN)

