

MITSUBISHI HVIGBT MODULES  
**CM600HG-90H**

3rd-Version HVIGBT (High Voltage Insulated Gate Bipolar Transistor) Modules

HIGH POWER SWITCHING USE  
**INSULATED TYPE**

**CM600HG-90H**



- IC ..... 600 A
- VCES ..... 4500 V
- High Insulated Type
- 1-element in a Pack
- AISiC Baseplate

**APPLICATION**

Traction drives, High Reliability Converters / Inverters, DC choppers

**OUTLINE DRAWING & CIRCUIT DIAGRAM**

Dimensions in mm

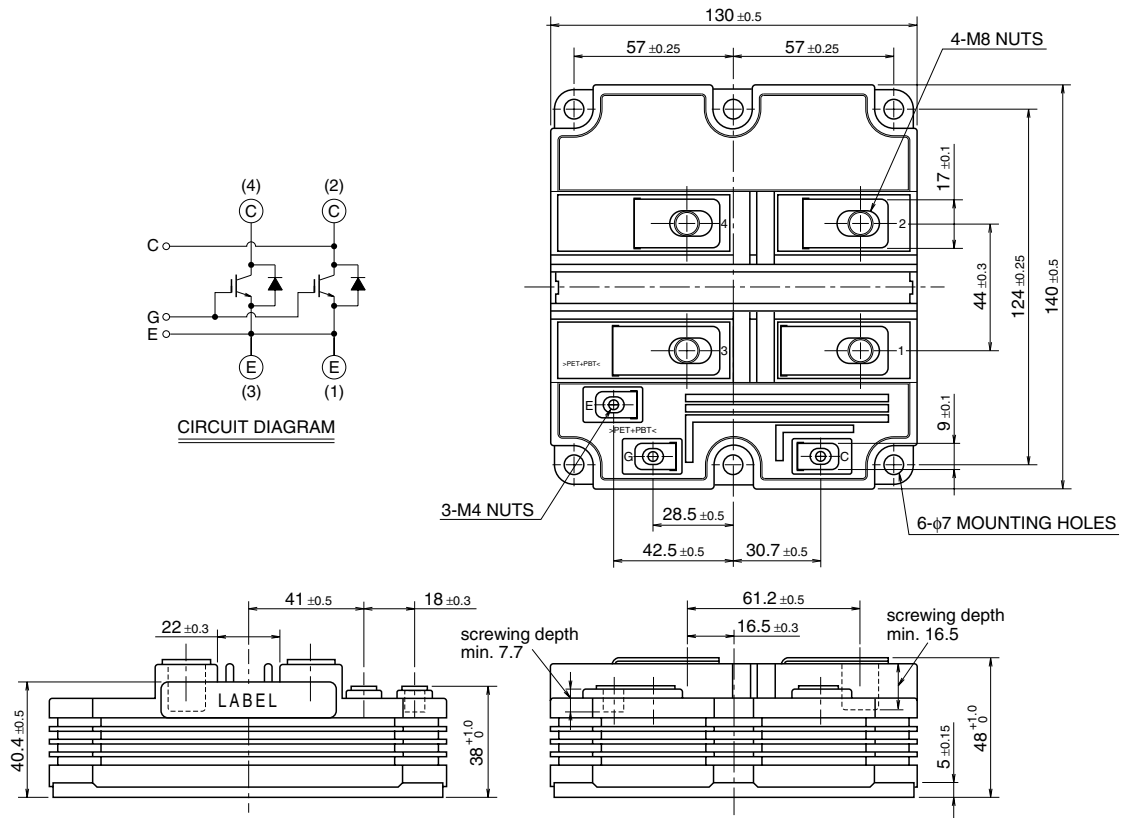

HVIGBT (High Voltage Insulated Gate Bipolar Transistor) Modules

May 2009

**CM600HG-90H**

**HIGH POWER SWITCHING USE  
INSULATED TYPE**

3rd-Version HVIGBT (High Voltage Insulated Gate Bipolar Transistor) Modules

**MAXIMUM RATINGS**

Symbol	Item	Conditions	Ratings	Unit
V <sub>CES</sub>	Collector-emitter voltage	V <sub>GE</sub> = 0V, T <sub>J</sub> = 25°C	4500	V
V <sub>GES</sub>	Gate-emitter voltage	V <sub>CE</sub> = 0V, T <sub>J</sub> = 25°C	± 20	V
I <sub>C</sub>	Collector current	DC, T <sub>c</sub> = 100°C	600	A
I <sub>CM</sub>		Pulse (Note 1)	1200	A
I <sub>E</sub>	Emitter current (Note 2)	DC	600	A
I <sub>EM</sub>		Pulse (Note 1)	1200	A
P <sub>c</sub>	Maximum power dissipation (Note 3)	T <sub>c</sub> = 25°C, IGBT part	7500	W
V <sub>iso</sub>	Isolation voltage	RMS, sinusoidal, f = 60Hz, t = 1 min.	10200	V
V <sub>e</sub>	Partial discharge extinction voltage	RMS, sinusoidal, f = 60Hz, Q <sub>PD</sub> ≤ 10 pC	5100	V
T <sub>J</sub>	Junction temperature		-40 ~ +150	°C
T <sub>op</sub>	Operating temperature		-40 ~ +125	°C
T <sub>stg</sub>	Storage temperature		-40 ~ +125	°C
t <sub>psc</sub>	Maximum short circuit pulse width	V <sub>CC</sub> = 3200V, V <sub>CE</sub> ≤ V <sub>CES</sub> , V <sub>GE</sub> = 15V, T <sub>J</sub> = 125°C	10	μs

**ELECTRICAL CHARACTERISTICS**

Symbol	Item	Conditions	Limits			Unit
			Min	Typ	Max	
I <sub>CES</sub>	Collector cutoff current	V <sub>CE</sub> = V <sub>CES</sub> , V <sub>GE</sub> = 0V T <sub>J</sub> = 25°C T <sub>J</sub> = 125°C	—	—	3.5 35	mA
V <sub>GE(th)</sub>	Gate-emitter threshold voltage	V <sub>CE</sub> = 10 V, I <sub>C</sub> = 60 mA, T <sub>J</sub> = 25°C	5.0	6.0	7.0	V
I <sub>GES</sub>	Gate leakage current	V <sub>GE</sub> = V <sub>GES</sub> , V <sub>CE</sub> = 0V, T <sub>J</sub> = 25°C	—	—	0.5	μA
C <sub>ies</sub>	Input capacitance	V <sub>CE</sub> = 10 V, V <sub>GE</sub> = 0 V, f = 100 kHz, T <sub>J</sub> = 25°C	—	108	—	nF
C <sub>oes</sub>	Output capacitance		—	8	—	nF
C <sub>res</sub>	Reverse transfer capacitance		—	2.4	—	nF
Q <sub>g</sub>	Total gate charge	V <sub>CC</sub> = 2250 V, I <sub>C</sub> = 600 A, V <sub>GE</sub> = ±15 V, T <sub>J</sub> = 25°C	—	10	—	μC
V <sub>CE(sat)</sub>	Collector-emitter saturation voltage	I <sub>C</sub> = 600 A (Note 4) V <sub>GE</sub> = 15 V T <sub>J</sub> = 25°C T <sub>J</sub> = 125°C	—	3.45 3.70	—	V
t <sub>d(on)</sub>	Turn-on delay time	V <sub>CC</sub> = 2250 V, I <sub>C</sub> = 600 A, V <sub>GE</sub> = ±15 V R <sub>G</sub> = 15 Ω, T <sub>J</sub> = 125°C, L <sub>S</sub> = 120 nH	—	—	2.40	μs
t <sub>r</sub>	Turn-on rise time		—	—	1.20	μs
E <sub>on(10%)</sub>	Turn-on switching energy (Note 5)	Inductive load	—	2.80	—	J/P
t <sub>d(off)</sub>	Turn-off delay time	V <sub>CC</sub> = 2250 V, I <sub>C</sub> = 600 A, V <sub>GE</sub> = ±15 V R <sub>G</sub> = 15 Ω, T <sub>J</sub> = 125°C, L <sub>S</sub> = 120 nH	—	—	6.00	μs
t <sub>f</sub>	Turn-off fall time		—	—	1.20	μs
E <sub>off(10%)</sub>	Turn-off switching energy (Note 5)	Inductive load	—	1.70	—	J/P
V <sub>EC</sub>	Emitter-collector voltage (Note 2)	I <sub>E</sub> = 600 A (Note 4) V <sub>GE</sub> = 0 V T <sub>J</sub> = 25°C T <sub>J</sub> = 125°C	—	4.80 4.15	—	V
t <sub>rr</sub>	Reverse recovery time (Note 2)	V <sub>CC</sub> = 2250 V, I <sub>E</sub> = 600 A, V <sub>GE</sub> = ±15 V R <sub>G</sub> = 15 Ω, T <sub>J</sub> = 125°C, L <sub>S</sub> = 120 nH Inductive load	—	—	1.80	μs
Q <sub>rr</sub>	Reverse recovery charge (Note 2)		—	610	—	μC
E <sub>rec(10%)</sub>	Reverse recovery energy (Note 2), (Note 5)		—	0.67	—	J/P

**CM600HG-90H**

**HIGH POWER SWITCHING USE  
INSULATED TYPE**

3rd-Version HVIGBT (High Voltage Insulated Gate Bipolar Transistor) Modules

**THERMAL CHARACTERISTICS**

Symbol	Item	Conditions	Limits			Unit
			Min	Typ	Max	
$R_{th(j-c)Q}$	Thermal resistance	Junction to Case, IGBT part	—	—	16.5	K/kW
$R_{th(j-c)R}$	Thermal resistance	Junction to Case, FWDi part	—	—	33.0	K/kW
$R_{th(c-f)}$	Contact thermal resistance	Case to Fin, $\lambda_{grease} = 1W/m-K$ , $D(c-f) = 100 \mu m$	—	9.0	—	K/kW

**MECHANICAL CHARACTERISTICS**

Symbol	Item	Conditions	Limits			Unit
			Min	Typ	Max	
$M_t$	Mounting torque	M8: Main terminals screw	7.0	—	15.0	N·m
$M_s$		M6: Mounting screw	3.0	—	6.0	N·m
$M_t$		M4: Auxiliary terminals screw	1.0	—	3.0	N·m
m	Mass		—	1.00	—	kg
CTI	Comparative tracking index		600	—	—	—
$d_a$	Clearance		26	—	—	mm
$d_s$	Creepage distance		56	—	—	mm
LP CE	Internal inductance		—	27	—	nH
$R_{CC+EE}$	Internal lead resistance	$T_c = 25^\circ C$	—	0.19	—	mΩ

- Note 1. Pulse width and repetition rate should be such that junction temperature ( $T_j$ ) does not exceed  $T_{opmax}$  rating (125°C).  
 2. The symbols represent characteristics of the anti-parallel, emitter to collector free-wheel diode (FWDi).  
 3. Junction temperature ( $T_j$ ) should not exceed  $T_{jmax}$  rating (150°C).  
 4. Pulse width and repetition rate should be such as to cause negligible temperature rise.  
 5.  $E_{on(10\%)} / E_{off(10\%)} / E_{rec(10\%)}$  are the integral of  $0.1V_{CE} \times 0.1I_C \times dt$ .

CM600HG-90H

HIGH POWER SWITCHING USE  
INSULATED TYPE

3rd-Version HVIGBT (High Voltage Insulated Gate Bipolar Transistor) Modules

PERFORMANCE CURVES

OUTPUT CHARACTERISTICS  
(TYPICAL)

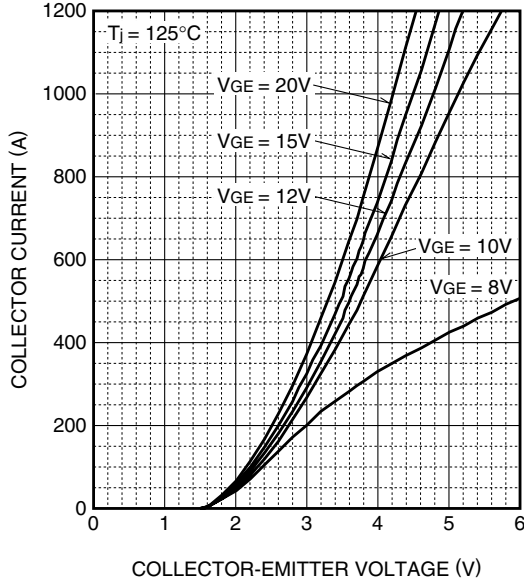

TRANSFER CHARACTERISTICS  
(TYPICAL)

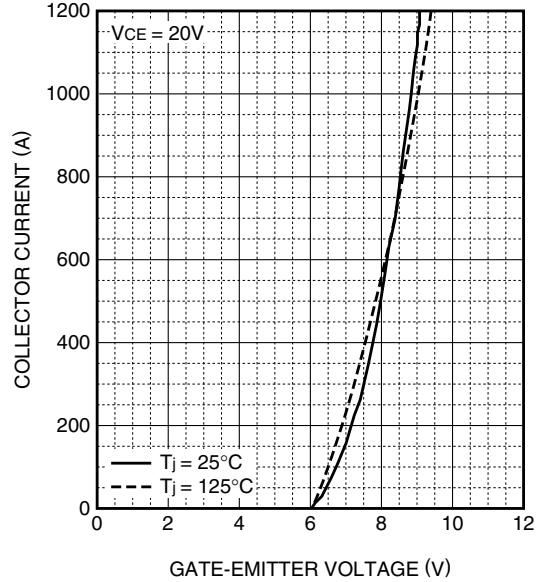

COLLECTOR-EMITTER SATURATION  
VOLTAGE CHARACTERISTICS  
(TYPICAL)

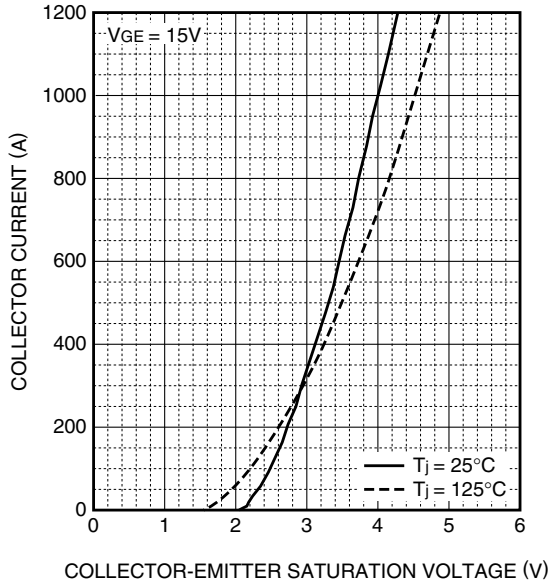

FREE-WHEEL DIODE  
FORWARD CHARACTERISTICS  
(TYPICAL)

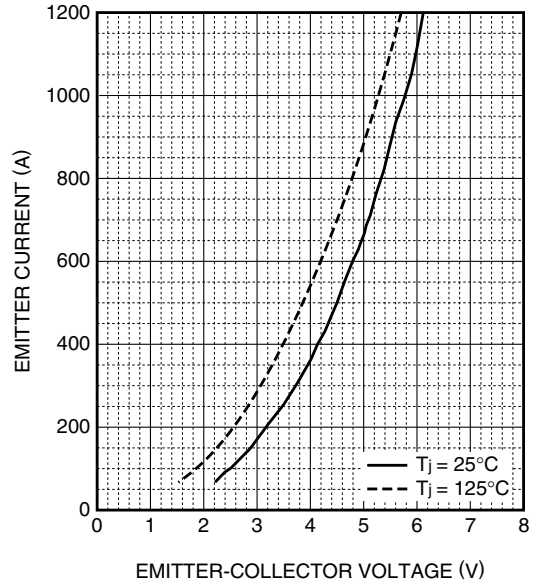

CM600HG-90H

HIGH POWER SWITCHING USE  
INSULATED TYPE

3rd-Version HVIGBT (High Voltage Insulated Gate Bipolar Transistor) Modules

CAPACITANCE CHARACTERISTICS  
(TYPICAL)

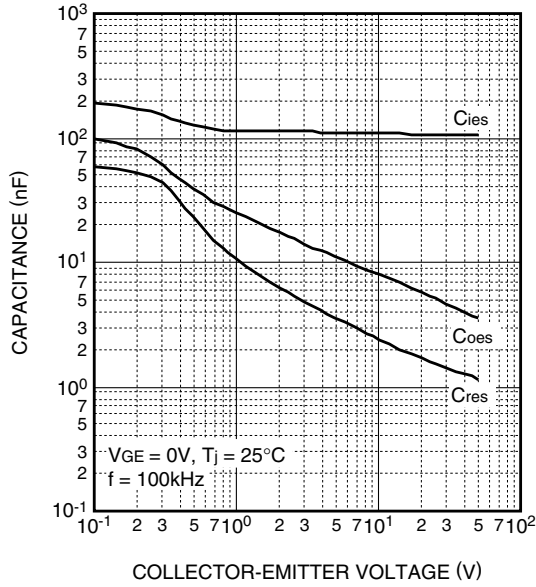

GATE CHARGE CHARACTERISTICS  
(TYPICAL)

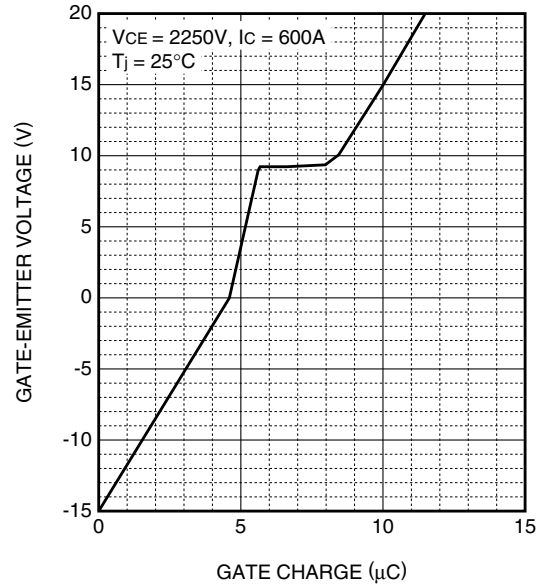

HALF-BRIDGE SWITCHING ENERGY  
CHARACTERISTICS  
(TYPICAL)

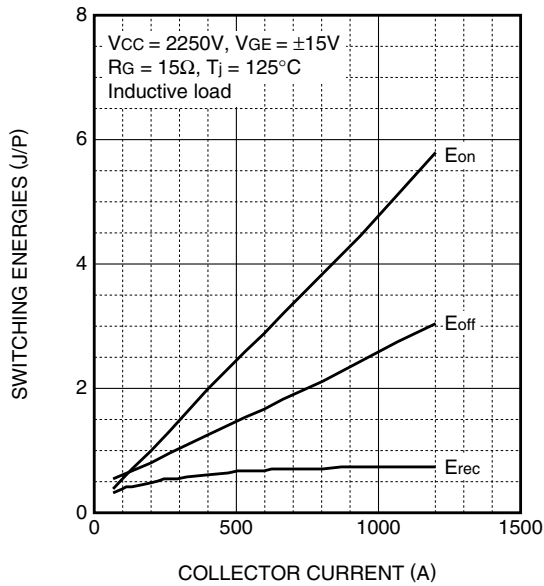

HALF-BRIDGE SWITCHING ENERGY  
CHARACTERISTICS  
(TYPICAL)

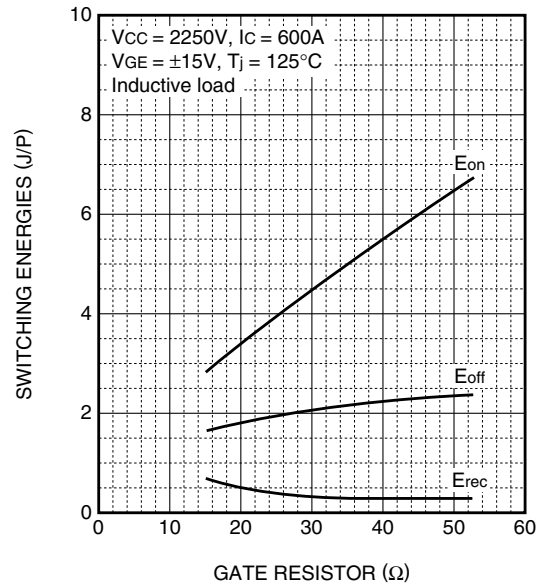

# CM600HG-90H

HIGH POWER SWITCHING USE  
INSULATED TYPE

3rd-Version HVIGBT (High Voltage Insulated Gate Bipolar Transistor) Modules

**HALF-BRIDGE SWITCHING TIME CHARACTERISTICS (TYPICAL)**

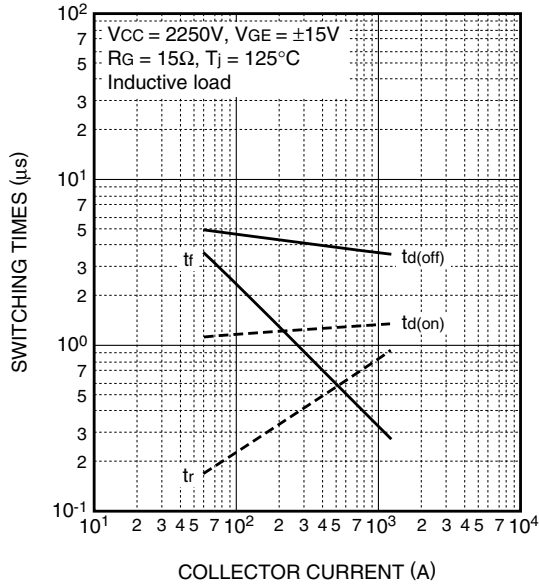

**FREE-WHEEL DIODE REVERSE RECOVERY CHARACTERISTICS (TYPICAL)**

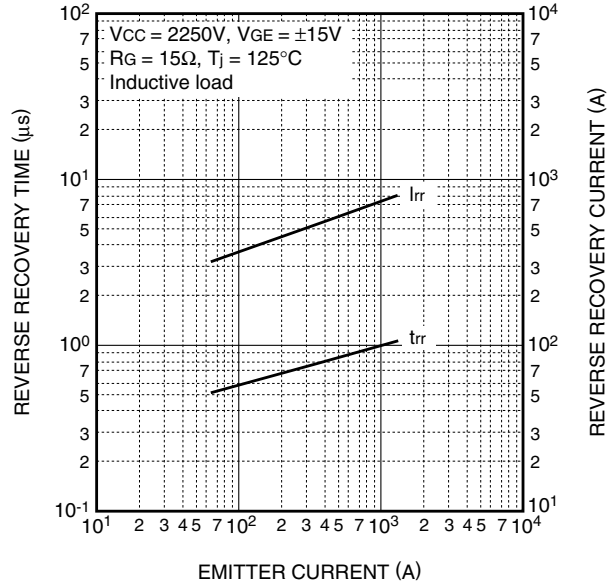

**TRANSIENT THERMAL IMPEDANCE CHARACTERISTICS**

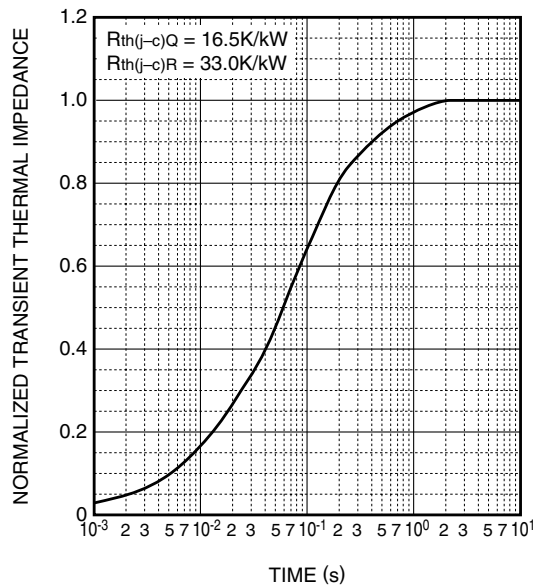

$$Z_{th(j-c)}(t) = \sum_{i=1}^n R_i \left\{ 1 - \exp\left(-\frac{t}{\tau_i}\right) \right\}$$

	1	2	3	4
$R_i$ [K/kW]	0.0059	0.0978	0.6571	0.2392
$\tau_i$ [sec]	0.0002	0.0074	0.0732	0.4488

**CM600HG-90H**

**HIGH POWER SWITCHING USE  
INSULATED TYPE**

3rd-Version HVIGBT (High Voltage Insulated Gate Bipolar Transistor) Modules

