

Femtosecond Streak Camera

C6138 (FESCA-200)



The FESCA-200 is an ultra fast streak camera with a temporal resolution of 200 femtoseconds (typ.). It is designed for use with single-shot or slow-repetitive phenomena. It can analyze the process of energy relaxation and the dynamics of chemical reaction in the femtosecond region in combination with femtosecond pulse laser.

*F*eatures

- Single-shot 200 fs (typ.) temporal resolution
- Simultaneous measurement of light intensity on both the temporal and spatial axis
- Dedicated readout system

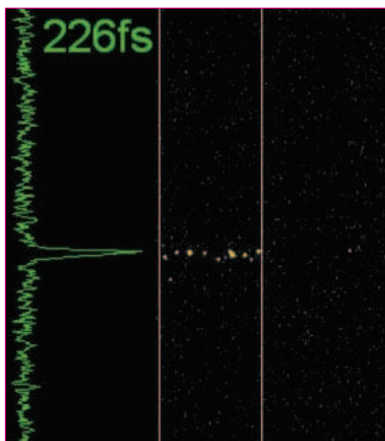

▲ Streak image and intensity profile of light pulses from Ti:Sapphire laser measured with the FESCA-200

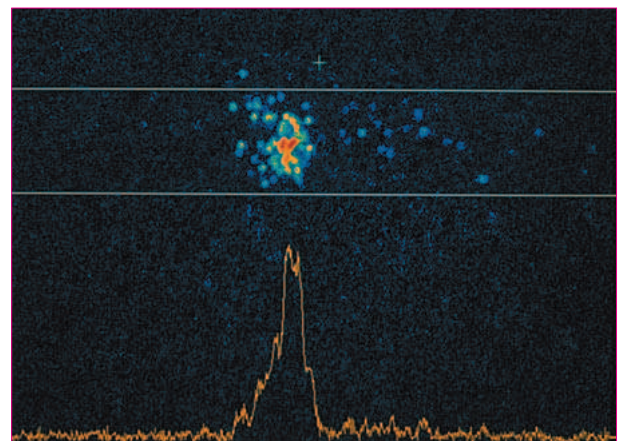

▲ This streak image, taken with the FESCA-200, was used to measure Cherenkov radiation. LINAC was used to generate an electronic pulse, which, in contact with the air, produced the Cherenkov radiation. Photo courtesy of Dr. Mitsuru Uesaka, Associate Professor, Nuclear Engineering Research Laboratory, Faculty of Engineering, University of Tokyo.

Applications

- Research of the process of energy relaxation of quantum well semiconductors
- Research of the dynamics of chemical reactions in the femtosecond region
- Research of the dynamics of ultra fast laser diodes, ultra fast optical logic devices, etc.
- Diagnosis of femtosecond lasers

System configuration

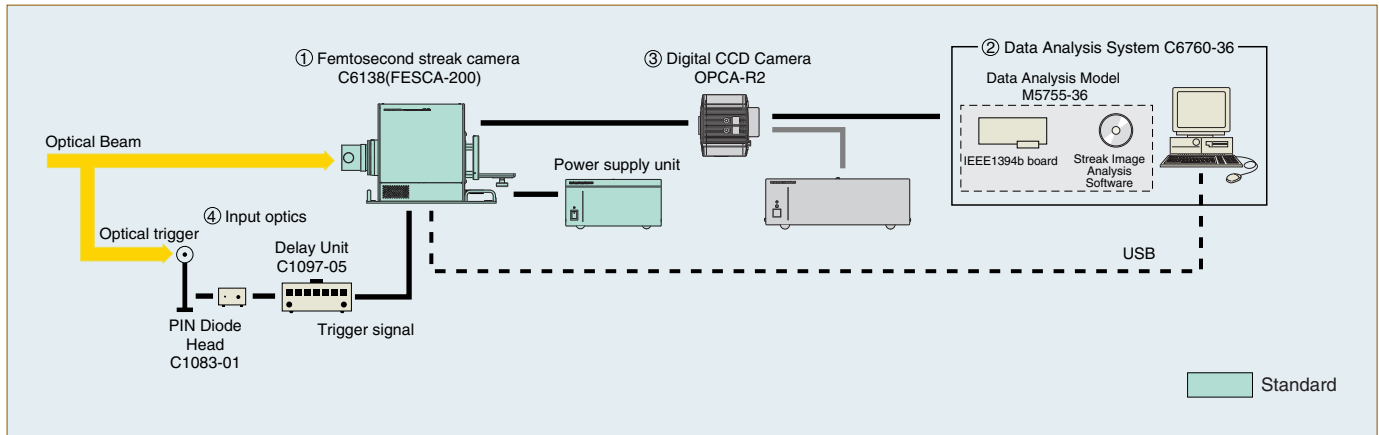

Operating Principle

The light pulse to be measured is projected onto the slit and is focused by the lens into an optical image on the photocathode of the streak tube. Changing the temporal and spatial offset slightly each time, four light pulses, each with a different light intensity, are introduced through the slit and conducted to the photocathode.

Here, the photons are converted into a number of electrons proportional to the intensity of the incident light. The four light pulses are converted sequentially to electrons which are then accelerated and conducted towards the photocathode.

As the group of electrons created from the four light pulses passes between a pair of sweep electrodes, a high-voltage is applied (see above), resulting in a high-speed sweep (the electrons are swept in the direction from top to bottom). The electrons are deflected at different times, and at slightly different angles in the perpendicular

direction, and are then conducted to the MCP (micro-channel plate). As the electrons pass the MCP, they are multiplied several thousands of times and are then bombarded against the phosphor screen, where they are converted back into light.

The fluorescence image corresponding to the first incident light pulse is positioned at the top of the phosphor screen, followed by the others, with images proceeding in descending order; in other words, the axis in the perpendicular direction on the phosphor screen serves as the temporal axis. The brightness of the various fluorescence images are proportional to the intensities of the corresponding incident light pulses. The positions in the horizontal direction on the phosphor screen correspond to the positions of the incident light in the horizontal direction.

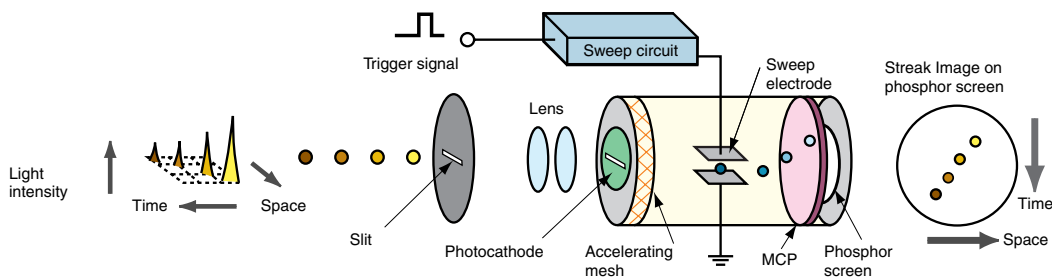

Operating Principle of the Streak Tube

Specifications

① Femtosecond Streak Camera C6138 (FESCA-200)

● Main body

Temporal resolution	200 fs (better than 300 fs) typ. (at the fastest sweep range)	
Effective phosphor screen size	Time axis	Approx. 10 mm
	Spatial axis	Approx. 9 mm
Sweep time/full screen (10 mm)	20 ps, 50 ps, 100 ps, 200 ps, 500 ps, 1 ns	
Trigger jitter	Less than ± 20 ps	
Trigger delay	Approx. 30 ns (at the fastest sweep range)	
Maximum sweep repetition frequency	100 Hz	
Trigger input	Maximum input voltage	± 5 V / 50 Ω
	Maximum input repetition frequency	150 MHz
	Trigger level	-4 V to +4 V
Power supply	AC 100 V to AC 240 V, 50 Hz/60 Hz	
Operating temperature	0 °C to +40 °C	
Operating humidity	Less than 70 % (with no condensation)	

● Streak tube

Photocathode/Material of Windows	Multi-alkali / Kovar glass
Effective photocathode size	Max. 3 mm (H)
Spectral response	280 nm to 850 nm
Phosphor screen size	ϕ 18 mm
Phosphor screen	P-43
Image magnification	1 : 3

● Image intensifier

Effective photocathode size	ϕ 18 mm
Photocathode	GaAsP
Light gain	More than 2500
Phosphor screen	P-43
Effective phosphor screen size	ϕ 18 mm

② Data Analysis System C6760-36

Application	For general	
Data Analysis Module	Type number	M5755-36
	Image Input board	IEEE1394b
	I/F	PCI
	Data acquisition	Monitoring, Analog integration, Photon counting
	External device control	Streak camera, Spectrometer etc.
	Profile analysis	Realtime monitoring, FWHM, Peak count etc.
	Calibration	Dark current, Shading, Time axis, Wavelength axis, Jitter
	File format (image)	Binary (16 bit), TIFF, ASCII
	File format (profile)	TEXT
Data processing	Windows PC	

③ Digital CCD Camera ORCA-R2

Type number	ORCA-R2	
Effective number of pixels	1344(H) \times 1024(V)	
Cell size	6.45 μ m (H) \times 6.45 μ m (V)	
Frame rate	Normal scan	8.5 Hz (binning : 1 \times 1)
		15.6 Hz (binning : 2 \times 2)
	Fast scan	16.2 Hz (binning : 1 \times 1)
		28.4 Hz (binning : 2 \times 2)
Readout noise (r.m.s.) typ.	Normal scan	6 electrons
	Fast scan	10 electrons
Dynamic range typ.	3 000 : 1 (Normal scan / binning : 1 \times 1)	
Cooling method / temperature	Forced-air cooled	- 35 °C
	Water cooled	- 40 °C (Water temperature : +20 °C)
Dark current	0.0005 electrons/pixel/s (- 40 °C)	
Dual A/D converter	12 bit or 16 bit	
Exposure time	10 μ s to 4200 s	

④ Input optics

Type number	Input optics A1976-01	Mirror optics A6856
Spectral transmittance	200 nm to 1600 nm	200 nm to 1600 nm
Image magnification	1 : 1	1 : 1
Effective F number	5.0	4.0

< Others >

- PIN Diode Head C1083-01
- Delay Unit C1097-05

Dimensional outlines (Unit:mm)

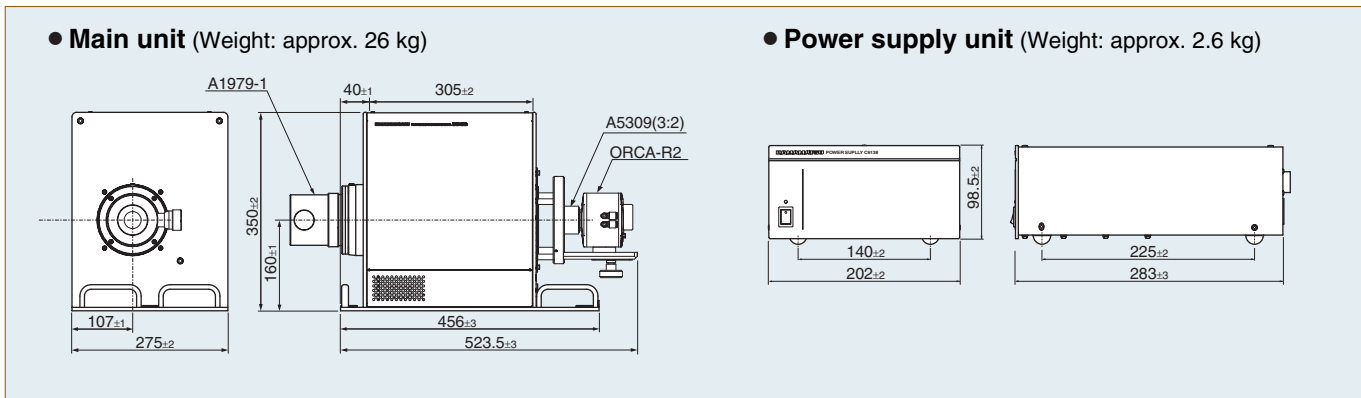

● The temporal resolution of Femtosecond Streak Camera C6138

The temporal resolution of C6138 can be limited depending on wavelength or input light intensity. (See Figure 1, 2)

The photoelectron from photocathode spread spatially along as the wavelength become shorter. Therefore, the temporal resolution is limited by wavelength.

The photoelectron can be spread spatially, each photoelectron bound back while traveling inside streak tube if a number of photoelectron is increased. Thus, the temporal resolution can be limited.

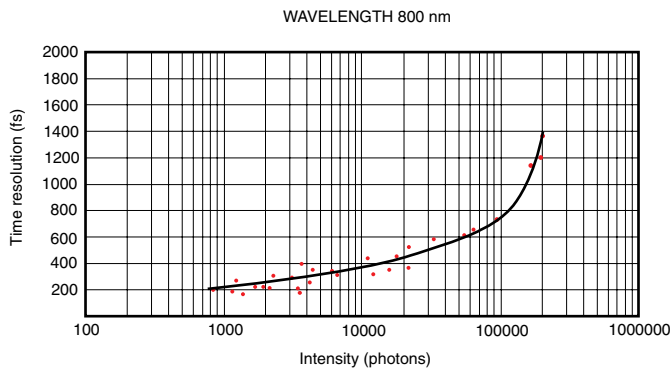

Figure 1

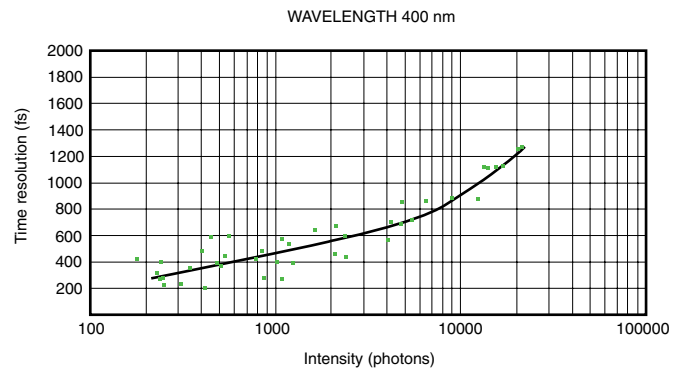

Figure 2

★Windows is a registered trademark of Microsoft Corporation in the U.S.A.

● Subject to local technical requirements and regulations, availability of products included in this promotional material may vary. Please consult your local sales representative.

● Information furnished by HAMAMATSU is believed to be reliable. However, no responsibility is assumed for possible inaccuracies or omissions.

Specifications and external appearance are subject to change without notice.

© 2010 Hamamatsu Photonics K.K.

HAMAMATSU

HAMAMATSU PHOTONICS K.K., Systems Division

812 Joko-cho, Higashi-ku, Hamamatsu City, 431-3196, Japan, Telephone: (81)53-431-0124, Fax: (81)53-433-8031, E-mail: export@sys.hpk.co.jp

U.S.A. and Canada: Hamamatsu Corporation: 360 Foothill Road, Bridgewater, N.J. 08807-0910, U.S.A., Telephone: (1) 908-231-0960, Fax: (1) 908-231-0852, E-mail: usa@hamamatsu.com

Germany: Hamamatsu Photonics Deutschland GmbH: Arzbergerstr. 10, D-82211 Herrsching am Ammersee, Germany, Telephone: (49)8152-375-0, Fax: (49)8152-2658, E-mail: info@hamamatsu.de

France: Hamamatsu Photonics France S.A.R.L.: 19, Rue du Saule Trapu, Parc du Moulin de Massy, 91882 Massy Cedex, France, Telephone: (33)1 69 53 71 00, Fax: (33)1 69 53 71 10, E-mail: infos@hamamatsu.fr

United Kingdom: Hamamatsu Photonics UK Limited: 2 Howard Court, 10 Tewin Road, Welwyn Garden City, Hertfordshire, AL7 1BW, U.K., Telephone: (44) 1707-294888, Fax: (44) 1707-325777, E-mail: info@hamamatsu.co.uk

North Europe: Hamamatsu Photonics Norden AB: Smidesvägen 12, SE-171-41 Solna, Sweden, Telephone: (46)8-509-031-00, Fax: (46)8-509-031-01, E-mail: info@hamamatsu.se

Italy: Hamamatsu Photonics Italia S.R.L.: Strada della Moia, 1 int.6-20020 Arese (Milano), Italy, Telephone: (39)02-935 81 733, Fax: (39)02-935 81 741, E-mail: info@hamamatsu.it

Homepage Address <http://www.hamamatsu.com>

Cat. No. SHSS0003E03
NOV/2010 HPK