

# TDI Camera C10000-701

## Time Delay Integration Camera



### FEATURES

- **High resolution / high sensitivity**  
(Horizontal spatial resolution with 128(V) TDI stages)  
- 4096(H) × 128 (V) , 16 TAP
- **Line rate up to 100 kHz**
- **High speed imaging combined with high sensitivity and low noise**
- **Great spectral response for UV-NIR with back thinned CCD**
- **100× anti-blooming with lateral overflow drain**
- **Dynamic range of 800 : 1 (C10000-701B)**
- **Bi-directional scanning operation**
- **Frame readout mode for easy focusing**
- **Internal real-time shading correction**

The C10000-701 TDI camera is useful for a wide range of imaging applications requiring high speed operation with high sensitivity simultaneously. TDI is a special image acquisition method that has been used extensively in machine vision applications for industrial inspection. TDI imaging is appropriate for applications where it is desired to record a linear process over time, or where the aspect ratio of the subject being imaged is significantly asymmetric. TDI is particularly useful for low light level scanning applications for which a typical line scan camera can not make a useful image. Also, frame readout mode is available for easy focusing.

### APPLICATIONS

- **High speed imaging for low light applications**  
i.e. fluorescence imaging
- **Electronics manufacturing and inspection**
- **Semiconductor inspection**
- **High speed scanning for a large size sample**  
i.e. flat panel displays

### OPERATING PRINCIPLE OF TDI

#### **TDI (Time Delay Integration):**

Time Delay Integration is a technology of scanning in which a frame transfer device produces a continuous video image of a moving object by means of a stack of linear arrays aligned with and synchronized to the motion of the object to be imaged in such a way that, as the image moves from one line to the next, the integrated charge moves along with it, providing higher resolution at lower light levels than is possible with a line-scan camera.

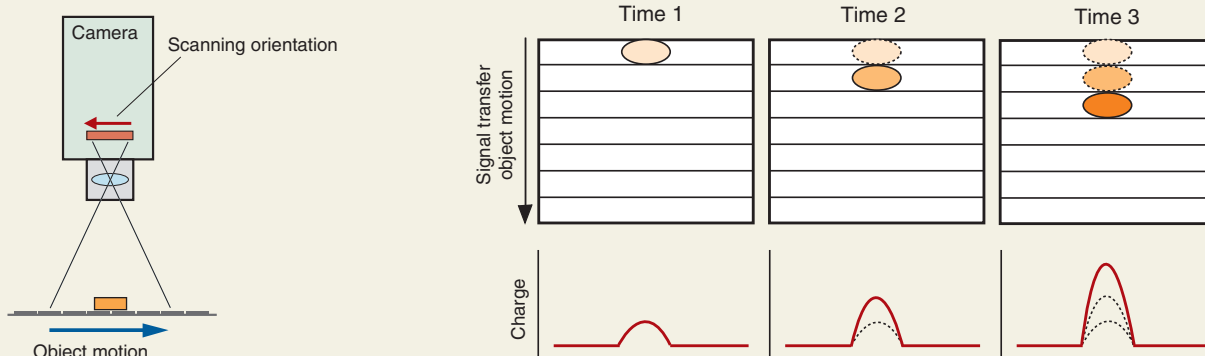

## SPECIFICATIONS

Type number	C10000-701A	C10000-701B
Pixel number	4096 (H) × 128 (V)	
Device structure	Back thinned type	
Cell size	12 μm (H) × 12 μm (V)	
Effective area	49.16 mm (H) × 1.536 mm (V)	
Readout mode	TDI readout mode or frame readout mode *1	
TDI transfer direction	Bi direction	
TDI output channel	16 TAP (256 × 16)	
Anti-blooming	Lateral overflow drain (100×)	
TDI pixel clock rate	30 MHz	
TDI line rate	0.45 kHz to 100 kHz	
TDI line rate control	Internal setting by serial command *2 / External trigger	
Full-well capacity (typ.)	80 000 electrons	
Readout noise (typ.)	100 electrons r.m.s.	
Dynamic range (typ.)	256 : 1	800 : 1
Binning	2 × 2	
Analog enhancement gain	1 time to 5 times (16 steps)	
A/D converter	8 bit	12 bit
Image processing	Internal real-time shading correction / Background subtraction	
Interface	Full Configuration ×1	Medium Configuration ×2
Camera control	Serial control in Camera Link	
Camera output clock	60 MHz	
Camera output channel	8 TAP (512 × 8)	
Camera Link connector	Mini-Camera Link (SDR) × 2	Mini-Camera Link (SDR) × 4
Lens mount	M72, P=0.75	
Power / Power consumption	DC +12 V / 36 W	
Ambient storage temperature	-10 °C to +50 °C	
Ambient operating temperature	0 °C to +40 °C	
Ambient operating / storage humidity	70 % max. (with no condensation)	

\*1 Frame readout mode is useful for easy focusing, but it is not suitable for measurement. Please consult with our sales office for details.

\*2 Internal TDI line rate is set by 33 ns step.

## SPECTRAL RESPONSE

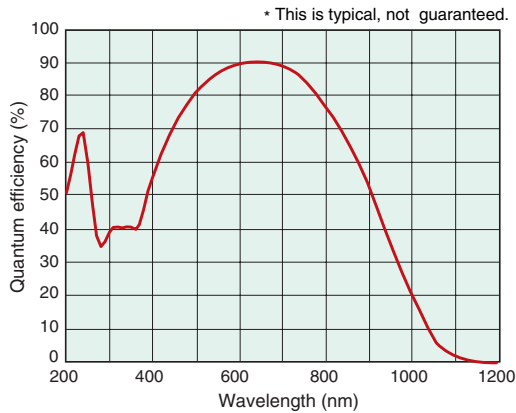

## DIMENSIONAL OUTLINES (Unit : mm)

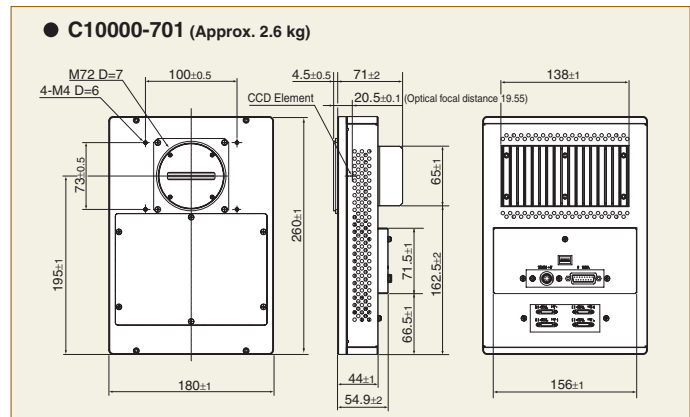

## TDI SENSOR STRUCTURES

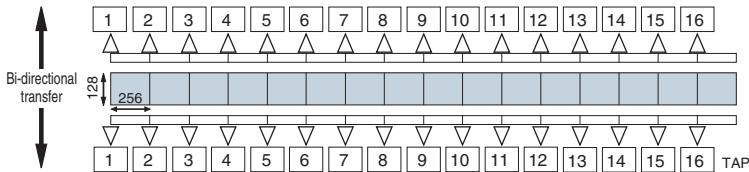

- ★ **Product and software package names noted in this documentation are trademarks or registered trademarks of their respective manufacturers.**
- Subject to local technical requirements and regulations, availability of products included in this promotional material may vary. Please consult your local sales representative.
  - Information furnished by HAMAMATSU is believed to be reliable. However, no responsibility is assumed for possible inaccuracies or omissions. Specifications and external appearance are subject to change without notice.

© 2010 Hamamatsu Photonics K.K.

**HAMAMATSU PHOTONICS K.K.** [www.hamamatsu.com](http://www.hamamatsu.com)

**HAMAMATSU PHOTONICS K.K., Systems Division**

**812 Joko-cho, Higashi-ku, Hamamatsu City, 431-3196, Japan, Telephone: (81)53-431-0124, Fax: (81)53-435-1574, E-mail: export@sys.hpk.co.jp**

**U.S.A.:** Hamamatsu Corporation: 360 Foothill Road, P. O. Box 6910, Bridgewater, N.J. 08807-0910, U.S.A., Telephone: (1)908-231-0960, Fax: (1)908-231-1218 E-mail: usa@hamamatsu.com

**Germany:** Hamamatsu Photonics Deutschland GmbH: Arzbergerstr. 10, D-82211 Herrsching am Ammersee, Germany, Telephone: (49)8152-375-0, Fax: (49)8152-2658 E-mail: info@hamamatsu.de

**France:** Hamamatsu Photonics France S.A.R.L.: 19, Rue du Saule Trapu, Parc du Moulin de Massy, 91882 Massy Cedex, France, Telephone: (33)1 69 53 71 00, Fax: (33)1 69 53 71 10 E-mail: infos@hamamatsu.fr

**United Kingdom:** Hamamatsu Photonics UK Limited: 2 Howard Court, 10 Tewin Road Welwyn Garden City Hertfordshire AL7 1BW, United Kingdom, Telephone: 44-(0)1707-294888, Fax: 44-(0)1707-325777 E-mail: info@hamamatsu.co.uk

**North Europe:** Hamamatsu Photonics Norden AB: Thorshamnsgatan 35 SE-164 40 Kista, Sweden, Telephone: (46)8-509-031-00, Fax: (46)8-509-031-01 E-mail: info@hamamatsu.se

**Italy:** Hamamatsu Photonics Italia: S.R.L.: Strada della Moia, 1/E, 20020 Arese, (Milano), Italy, Telephone: (39)02-935 81 733, Fax: (39)02-935 81 741 E-mail: info@hamamatsu.it

**China:** Hamamatsu Photonics (China) Co., Ltd.: 1201 Tower B, Jianning Center, 27 Dongsanhuan Road North, Chaoyang District, Beijing 100020, China, Telephone: (86)10-6586-6006, Fax: (86)10-6586-2866 E-mail: hpc@hamamatsu.com.cn

Cat. No. SCAS0053E07  
SEP/2010 HPK  
Created in Japan