

High Speed CCD Camera C9300-221



The C9300-221 is a VGA-format high-speed digital CCD camera using a high-speed progressive interline transfer CCD with no mechanical shutter. Peltier cooling with forced air radiation system drastically reduces dark noise and minimizes thermal drift, which makes camera an ideal choice for demanding scientific and industrial application. Low noise performance realizes 12 bit digital output even with 82 frames/s. The dual readout mode realizes 150 frames/s with full resolution. Furthermore, a standard C-mount lens coupling makes it easy to connect to optics such as optical microscopes.

APPLICATIONS

- IR-DIC imaging
- Calcium ion imaging
(Fluorescent probe:Fura-2, Fluo-3, Indo-1)
- Bright fluorescent imaging
- Membrane potential measurement
(Di-8-ANEPPS, DiBAC4)

SYSTEM CONFIGURATION

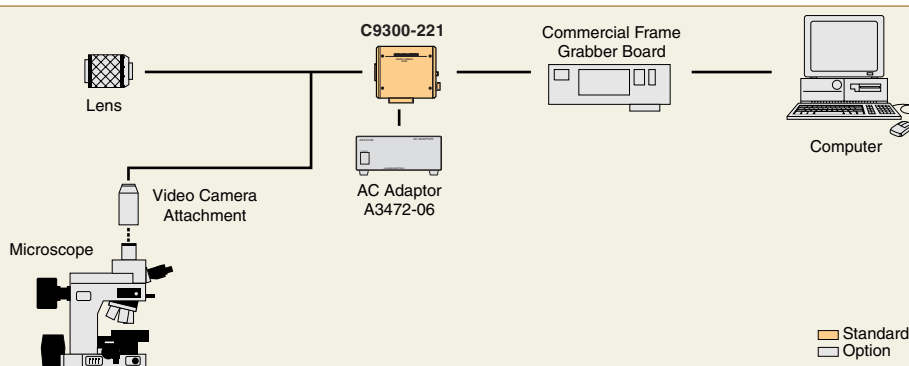

SPECTRAL RESPONSE

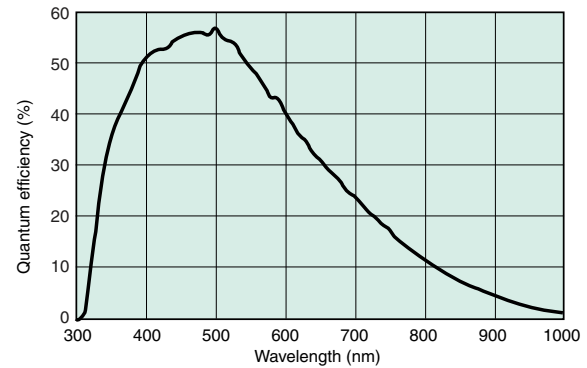

★ This is typical, not guaranteed

FEATURES

- High speed progressive scan interline CCD with no mechanical shutter
- 150 Hz frame rate with VGA full resolution
- 33 μ s electronic shutter to capture fast events
- Wide range sensitivity from Blue to NIR
- Low readout noise (20 electrons r.m.s.)
- Large fullwell capacity
- Low dark noise with peltier cooling with forced air radiation system

OPTIONS

- AC Adaptor A3472-06
 - Line voltage : 100 V to 240 V AC input
 - Output voltage : DC +12 V
- Power Cable A9071-05
 - Cable length : 5 m

HAMAMATSU

SPECIFICATIONS

Type number	C9300-221		
Camera head type	Forced air-cooled head		
Imaging device	Progressive interline transfer CCD		
Effective no. of pixels	640 (H) × 480 (V)		
Cell size	7.4 μm (H) × 7.4 μm (V)		
Effective area	4.74 mm (H) × 3.55 mm (V)		
Pixel clock rate	30 MHz		
Frame rate	1 × 1	Single readout	82 Hz
		Dual readout	150 Hz
	2 × 2	Single readout	155 Hz
		Dual readout	274 Hz
	4 × 4	Single readout	280 Hz
		Dual readout	461 Hz
	8 × 8	Single readout	465 Hz
		Dual readout	694 Hz
Cooling method	Peltier with forced air radiation system		
Cooling temperature	0 °C to +5 °C (at 20 °C ambient temperature)		
Dark current (typ.)	2 electrons/pixel/s		
Readout noise (typ.)	20 electrons *		
Full well capacity (typ.)	20000 electrons		
A/D converter	12 bit		
Interface	Camera Link		
Exposure time	33.1 μs to 10 s		
External trigger	Yes		
Lens mount	C-mount		
Power requirements	DC +12 V		
Power consumption	approx. 10 V·A		
Ambient storage temperature	- 10 °C to + 50 °C		
Ambient operating temperature	0 °C to + 40 °C		

* This value is the measurement in free running mode and scan mode (normal readout). The value was measured with the CCD in dark state. In this state, two images are acquired, image subtraction performed, the standard deviation taken from the results, and this value was then squared and plugged into a transformation coefficient.

DIMENSIONAL OUTLINES (mm)

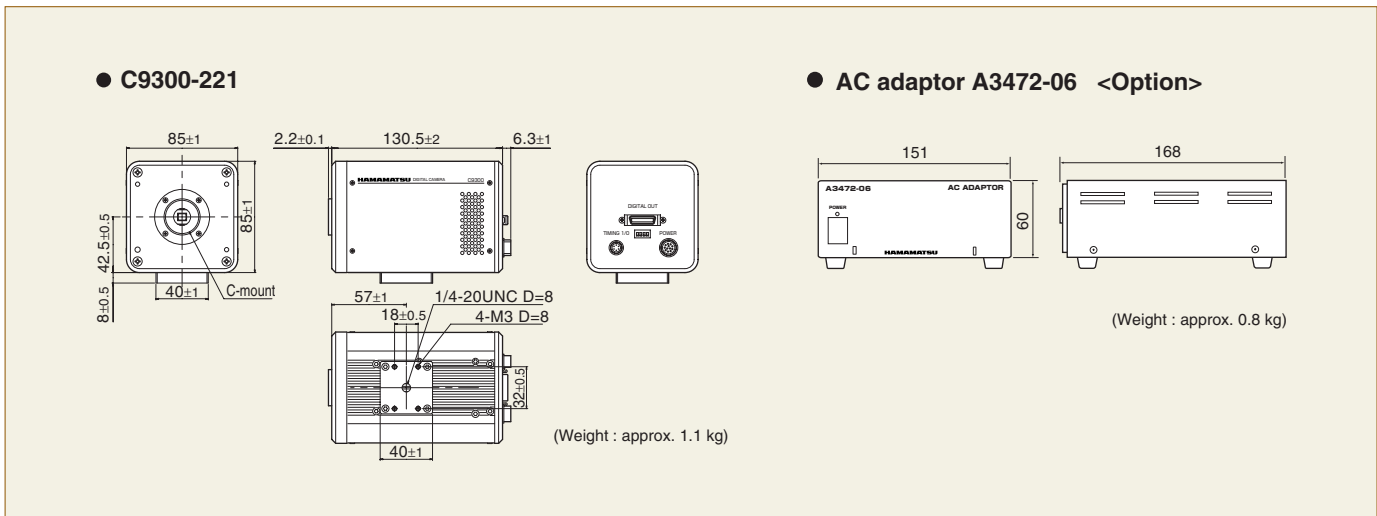

★ **Product and software package names noted in this documentation are trademarks or registered trademarks of their respective manufacturers.**

- Subject to local technical requirements and regulations, availability of products included in this promotional material may vary. Please consult with our sales office.
- Information furnished by HAMAMATSU is believed to be reliable. However, no responsibility is assumed for possible inaccuracies or omissions.

Specifications and external appearance are subject to change without notice.

© 2008 Hamamatsu Photonics K.K.

HAMAMATSU

<http://www.hamamatsu.com>

HAMAMATSU PHOTONICS K.K., Systems Division

812 Joko-cho, Higashi-ku, Hamamatsu City, 431-3196, Japan, Telephone: (81)53-431-0124, Fax: (81)53-435-1574, E-mail: export@sys.hpk.co.jp

U.S.A. and Canada: Hamamatsu Corporation: 360 Foothill Road, Bridgewater, N.J. 08807-0910, U.S.A., Telephone: (1) 908-231-0960, Fax: (1) 908-231-0852, E-mail: usa@hamamatsu.com

Germany: Hamamatsu Photonics Deutschland GmbH: Arzbergerstr. 10, D-82211 Herrsching am Ammersee, Germany, Telephone: (49)8152-375-0, Fax: (49)8152-2658, E-mail: info@hamamatsu.de

France: Hamamatsu Photonics France S.A.R.L.: 19, Rue du Saule Trapu, Parc du Moulin de Massy, 91882 Massy Cedex, France, Telephone: (33)1 69 53 71 00, Fax: (33)1 69 53 71 10, E-mail: infos@hamamatsu.fr

United Kingdom: Hamamatsu Photonics UK Limited: 2 Howard Court, 10Tewin Road, Welwyn Garden City, Hertfordshire, AL7 1BW, U.K., Telephone: (44) 1707-294888, Fax: (44) 1707-325777, E-mail: info@hamamatsu.co.uk

North Europe: Hamamatsu Photonics Norden AB: Smidesvägen 12, SE-171-41 Solna, Sweden, Telephone: (46)8-509-031-00, Fax: (46)8-509-031-01, E-mail: info@hamamatsu.se

Italy: Hamamatsu Photonics Italia S.R.L.: Strada della Moia, 1/E 20020 Arese (Milano), Italy, Telephone: (39)02-935 81 733, Fax: (39)02-935 81 741, E-mail: info@hamamatsu.it

Cat. No. SCAS0050E01
MAR/2008 HPK