

HAMAMATSU

DATA SHEET

4M-pixels Cooled CCD Digital Camera C9300-024 (2048 × 2048)



The C9300-024 is a 2k × 2k high-resolution digital camera using a high-speed interline transfer CCD chip with on chip micro-lens. In addition to a high resolution of 4 million pixels, low noise performance realizes 12 bit digital output even with 6 frames per second. The dual readout mode realize 11 frames per second with full resolution. Peltier cooling drastically reduces dark noise and minimizes thermal drift, which makes the camera an ideal choice for demanding scientific and industrial applications.

APPLICATIONS

- FPD inspection
- Continuous imaging of high-speed moving objects
- Kinetic changes in light intensity
- Faint light observation under a microscope

SYSTEM CONFIGURATION

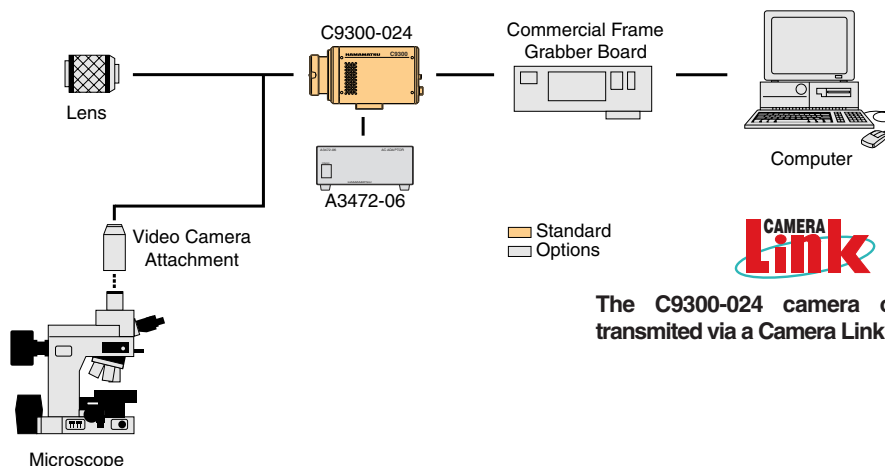

SPECTRAL RESPONSE CHARACTERISTIC

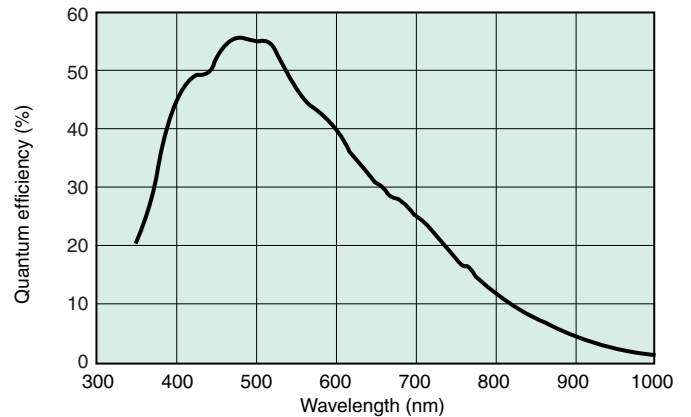

★ This is typical, not guaranteed

FEATURES

- 11 frame/s with 4 million full resolution
- Low readout noise (25 electrons r.m.s. typ.)
- Large full well capacity
- Wide range sensitivity from Blue to NIR
- Low dark noise with peltier cooling
- Fast repetition readout mode for PIV

OPTIONS

- AC adaptor : A3472-06
Line voltage: 100 V AC to 240 V AC input
Output voltage: DC +12 V
- Power cable : A9071-05 (5 m)

The C9300-024 camera outputs data is transmitted via a Camera Link interface.

SPECIFICATIONS

Type number	C9300-024		
Camera head type	Passive air-cooled head		
Imaging device	Progressive interline transfer CCD		
Effective no. of pixels	2048 (H) × 2048 (V)		
Cell size	7.4 μm (H) × 7.4 μm (V)		
Effective area	15.2 mm (H) × 15.2 mm (V)		
Pixel clock rate	30 MHz/pixel		
Full well capacity (typ.)	20 000 electrons		
Frame rate	1 × 1	Single readout : 6.3 frame/s, Dual readout : 11.5 frame/s	
	binning	(2 × 2)	Single readout : 11.6 frame/s, Dual readout : 20.0 frame/s
		(4 × 4)	Single readout : 20.2 frame/s, Dual readout : 31.6 frame/s
		(8 × 8)	Single readout : 31.9 frame/s, Dual readout : 44.5 frame/s
Cooling method	Peltier cooling, air radiation system		
Cooling temperature	+ 5 °C to + 7 °C		
Dark current (typ.)	2 electrons/pixel/s		
Readout noise (r.m.s.) (typ.)	25 electrons		
Dynamic range* (typ.)	800 : 1		
A/D converter	12 bit		
Lens mount	F-mount		
Contrast enhancement	1 to 5 times(16 step)		
Exposure time	102 μs to 1 s		
Sub-array	A setup in an eight-line unit (vertical, perpendicular) is possible in size and a position.		
External trigger	Yes		
Output signal	Camera Link		
External control	Camera Link		
Ambient storage temperature	- 10 °C to + 50 °C		
Ambient operating temperature	0 °C to + 40 °C		
Ambient operating/storage humidity	70 % max. (with no condensation)		
Power requirements	DC +12 V		
Power consumption	approx. 20 V·A		

Calculated from the ratio of the full well capacity and the readout noise

DIMENSIONAL OUTLINES (Unit: mm)

● C9300-024 (approx. 1.2 kg)

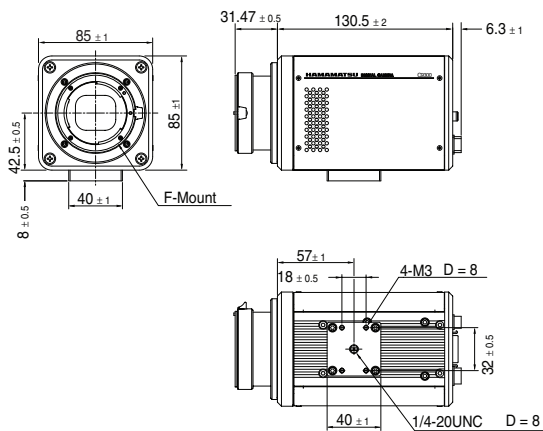

● A3472-06 (approx. 0.8 kg) - Option -

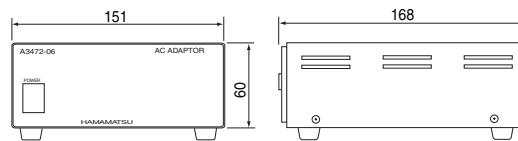

- ★ Product and software package names noted in this documentation are trademarks or registered trademarks of their respective manufacturers.
 - Subject to local technical requirements and regulations, availability of products included in this promotional material may vary. Please consult with our sales office.
 - Information furnished by HAMAMATSU is believed to be reliable. However, no responsibility is assumed for possible inaccuracies or omissions.
- Specifications and external appearance are subject to change without notice.

© 2007 Hamamatsu Photonics K.K.

HAMAMATSU

<http://www.hamamatsu.com>

HAMAMATSU PHOTONICS K.K., Systems Division

812 Joko-cho, Higashi-ku, Hamamatsu City, 431-3196, Japan, Telephone: (81)53-431-0124, Fax: (81)53-435-1574, E-mail: export@sys.hpk.co.jp

U.S.A. and Canada: Hamamatsu Corporation: 360 Foothill Road, Bridgewater, N.J. 08807-0910, U.S.A., Telephone: (1) 908-231-0960, Fax: (1) 908-231-0852, E-mail: usa@hamamatsu.com

Germany: Hamamatsu Photonics Deutschland GmbH: Arzbergerstr. 10, D-82211 Herrsching am Ammersee, Germany, Telephone: (49)8152-375-0, Fax: (49)8152-2658, E-mail: info@hamamatsu.de

France: Hamamatsu Photonics France S.A.R.L.: 19, Rue du Saule Trapu, Parc du Moulin de Massy, 91882 Massy Cedex, France, Telephone: (33)1 69 53 71 00, Fax: (33)1 69 53 71 10, E-mail: infos@hamamatsu.fr

United Kingdom: Hamamatsu Photonics UK Limited: 2 Howard Court, 10 Twin Road, Welwyn Garden City, Hertfordshire, AL7 1BW, U.K., Telephone: (44) 1707-294888, Fax: (44) 1707-325777, E-mail: info@hamamatsu.co.uk

North Europe: Hamamatsu Photonics Norden AB: Smidesvägen 12, SE-171-41 Solna, Sweden, Telephone: (46)8-509-031-00, Fax: (46)8-509-031-01, E-mail: info@hamamatsu.se

Italy: Hamamatsu Photonics Italia S.R.L.: Strada della Moia, 1/E 20020 Arese (Milano), Italy, Telephone: (39)02-935 81 733, Fax: (39)02-935 81 741, E-mail: info@hamamatsu.it

Cat. No. SCAS0017E02
FEB/2008 (2007.10) HPK
Created in Japan (PDF)