

APD module C10508

Variable gain and stable detection even at high gains



Along with an APD, current-to-voltage conversion circuit, and high-voltage power supply circuit, the C10508 contains a microcontroller to perform temperature compensation based on information from the internal thermosensor. Because temperature coefficients that match the APD temperature characteristics are written in the microprocessor chip, the APD can be operated with a highly stable gain over a wide temperature range even at high gain levels. The gain can be changed by the switch on the board or a command from a PC.

Features

- Gain fluctuation with temperature: $\pm 5\%$ Max. (M=250, $T_a=0$ to 40°C)
- Easily adjustable gain: Adjustable by switch or by PC command
- Easy handling: $\pm 5\text{ V}$ supply voltage
- Compact and lightweight

Applications

- APD evaluation
- Power meter
- Low-light-level detection

Block diagram

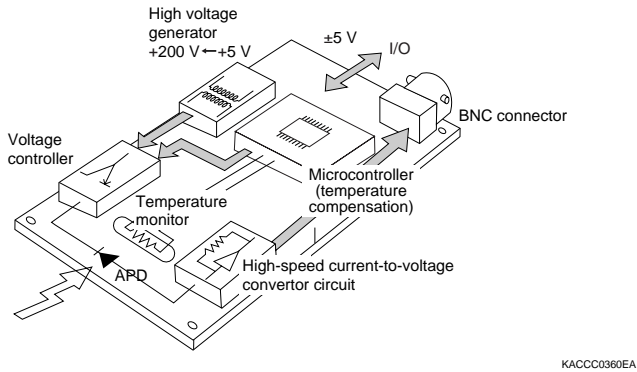

Photoelectric sensitivity vs. cut-off frequency

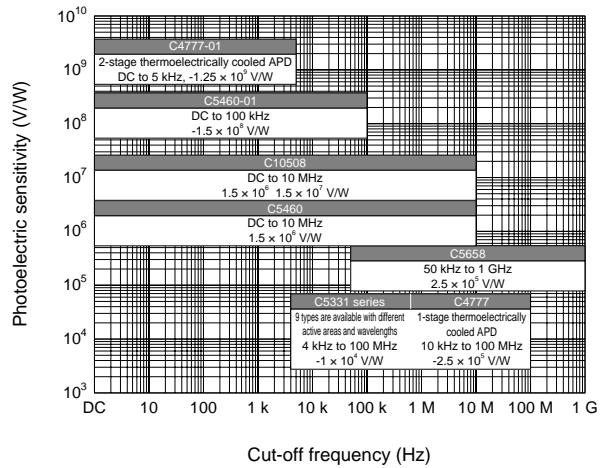

General ratings

Parameter	Symbol	Condition	Min.	Typ.	Max.	Unit
Supply voltage	Vs	+5 V	+4.6	+5.0	+5.4	V
		-5 V	-4.6	-5.0	-5.4	V
Current consumption	-	+5 V	-	+50	+75	mA
		-5 V	-	-15	-25	mA

Absolute maximum ratings (Ta=25 °C)

Parameter	Symbol	Value	Unit
Positive supply voltage	Vp	+6	V
Negative supply voltage	Vn	-6	V
Maximum input light intensity	-	10	mW
Operating temperature	Topr	0 to +60	°C
Storage temperature	Tstg	-30 to +70	°C

* No condensation

Specifications (Typ. Ta=25 °C, λ=800 nm, unless otherwise noted)

Parameter	Symbol	Condition	Value			Unit
Active area	A		φ1.0			mm
Spectral response range	λ		400 to 1000			nm
Peak sensitivity wavelength	λp		800			nm
Photo sensitivity	S	M=1, λ=800 nm	0.5			A/W
Feedback resistance	Rf		-	10	-	kΩ
Latter-stage amplifier gain	-		-	10	-	times
Output polarity	-		Positive			-
Cut-off frequency	High band	M=10 to 250, -3 dB	8	10	-	MHz
	Low band		-	DC	-	-
APD gain	M		Adjustable by switch or serial communication			-
Temperature stability of gain	-	M=10 to 250 Ta=0 °C to 40 °C	-	-	±5	%
Photoelectric sensitivity	-	M=250, λ=800 nm	1.0 × 10 ⁷	1.25 × 10 ⁷	1.5 × 10 ⁷	V/W
Noise equivalent power	NEP	M=250, λ=800 nm	-	0.02	0.04	pW/Hz ^{1/2}
Minimum detection limit	-	M=250, λ=800 nm	-	63	126	pW rms
Saturation input light intensity	-	M=250, λ=800 nm	-	0.24	-	μW
Interface	-		RS-232C			

■ Spectral response

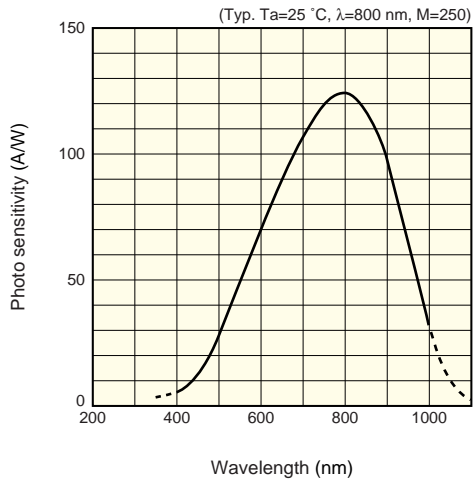

KACCB0183EA

■ Gain temperature characteristic

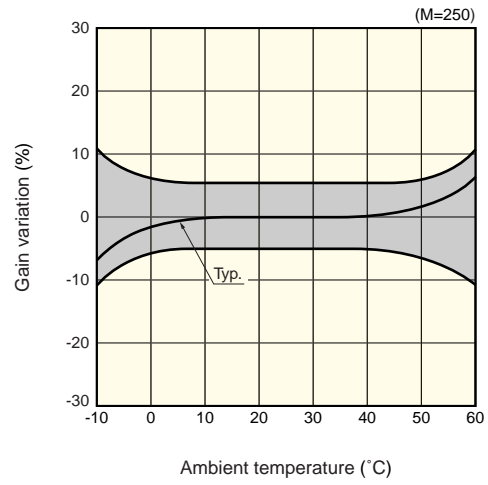

KACCB0185EA

■ Frequency response

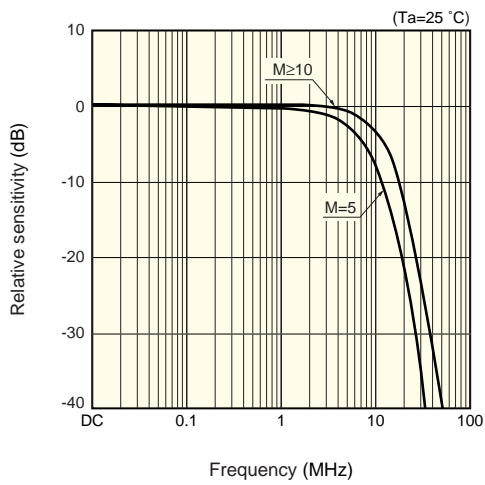

KACCB0184EB

■ Response to stepped light

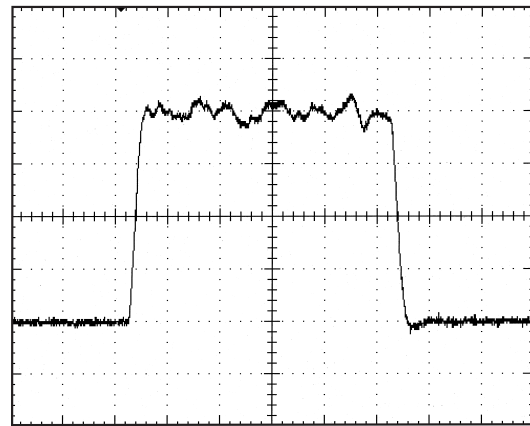

Ta=25 °C, gain M=250, input pulse width=1 μ s
X-axis: 200 ns/div., Y-axis: 100 mV/div.

KACCC0399EA

■ Dimensional outline (unit: mm, tolerance unless otherwise noted: ±0.3)

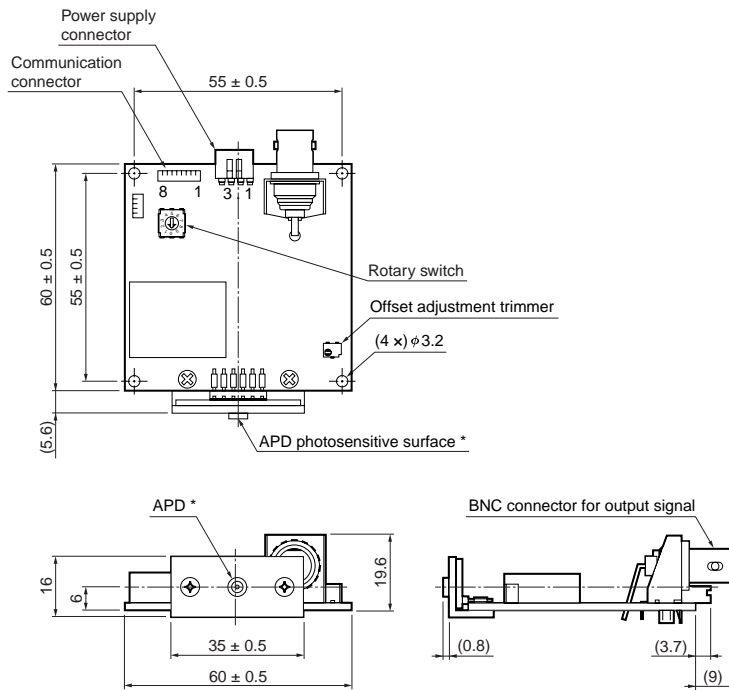

* Position accuracy of effective active area with respect to the APD package: ±0.3 mm

Power supply connector
(supplied with cable)
Molex: 5484-03AX
① -5 V
② GND
③ +5 V

Communication connector
(supplied with cable)
Molex: 53047-0810
① GND
② DSR
③ RTS
④ RxD
⑤ CTS
⑥ DTR
⑦ TxD
⑧ DCD

KACCA0236EB

■ Changing the gain

· Changing the gain by the rotary switch

The rotary switch on the PC board allows you to change the gain. Gain setting for each switch number is shown below.

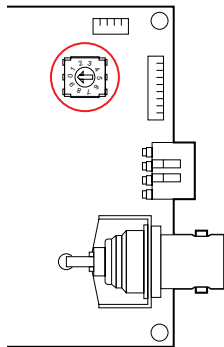

No.	Function
0	Cannot be used
1	Gain: 10
2	Gain: 30
3	Gain: 50
4	Gain: 75
5	Gain: 100
6	Gain: 150
7	Gain: 250
8	Gain: Users setting
9	PC control mode

· Changing the gain by command from the PC

Setting the rotary switch to "9" enters PC control mode. In this mode, the gain can be set to any integer value from 5 to 400 times.

Note that this gain setting is lost when the power is turned off.

■ Communication with PC

- Setting
 - Bound rate: 9600 bps
 - Data bits: 8 bits
 - Parity: none
 - Stop bit: 1 bit
 - Flow control: none

· Command

Command	Description
#UG	This command inquires the currently set gain value. Default gain is 10.
#US	This command sets the gain used with switch "9". Setting range is from 5 to 400. An error occurs if the setting is outside this range. The gain is set to the same value as switch "8" when the power is turned on.
#UW	This command sets the gain used with switch "8". Setting range is from 5 to 400. An error occurs if the setting is outside this range. The setting is retained even after the power is turned off.

· Transmitted data format (ASCII code: 9 characters)

9	8	7	6	5	4	3	2	1
#	AA		xxxx				<CR>	<LF>

No.	Description
9	#
8-7	Command (2 bytes: US/UG/UW)
6-3	Data (4 bytes: 0000 ... 9999)
2-1	Terminator (2 bytes: carriage return + line feed)

· Received data format (ASCII code: 9 characters)

9	8	7	6	5	4	3	2	1
* or \$	AA		xxxx				<CR>	<LF>

No.	Description
9	* (OK) or \$ (Error)
8-7	Command (2 bytes: echo back)
6-3	Data (4 bytes: 0000 ... 9999)
2-1	Terminator (2 bytes: carriage return + line feed)

■ Sample software

Sample software is included on the CD-ROM that comes with the C10508. The software allows controlling the C10508 from a PC. Use this to check the operation of the C10508.

· Operation screen of sample software

